



# WSM20L

## 20-Quart Planetary Mixer



# Luna 20



### MAIN FEATURES

- Large, 20-quart stainless steel bowl with stainless steel handle
- Heavy duty, 1 HP induction motor
- Side-mounted controls
- 3 mixing speeds
- Heavy-duty bowl-lift lever
- Gear driven, permanent lube transmission
- Thermal overload protection
- Includes stainless steel bowl, chef's whisk, dough hook, and aluminum mixing paddle
- Specifically designed for countertop use
- Non-slip rubber feet
- Limited Two-Year Motor Warranty, One Year Parts & Labor

### ELECTRICAL

Voltage: 120

Frequency: 60Hz

Watts: 1100

Amps: 14

Plug Type: NEMA 5-15P 

Cord Length: 6 feet



### SALES FEATURES

Equipped with a powerful 1 HP motor, this heavy-duty, 20 qt. planetary mixer is perfect for high-traffic cafes and restaurant kitchens. Mix ingredients for baked goods and desserts quickly and easily. Power through batters, mashed potatoes, and more. The variable control with 3 mixing speeds ensures efficiency and versatility. The gear-driven design with thermal overload protection makes this mixer especially reliable.



@waringcommercial

©2019 Waring Commercial  
314 Ella T. Grasso Avenue, Torrington, CT 06790  
Tel. 800-492-7464 • Fax 860-496-9008

[waringcommercialproducts.com](http://waringcommercialproducts.com)

20-Quart Planetary Mixer

WSM20L



# 20-Quart Planetary Mixer WSM20L

## PARTS & ACCESSORIES



**WSM20LMP** Aluminum Mixing Paddle



**WSM20LW** Stainless Steel Chef's Whisk



**WSM20LDH** Stainless Steel Dough Hook



**WSM20LBL** 20-Quart Stainless Steel Bowl

## DIMENSIONS

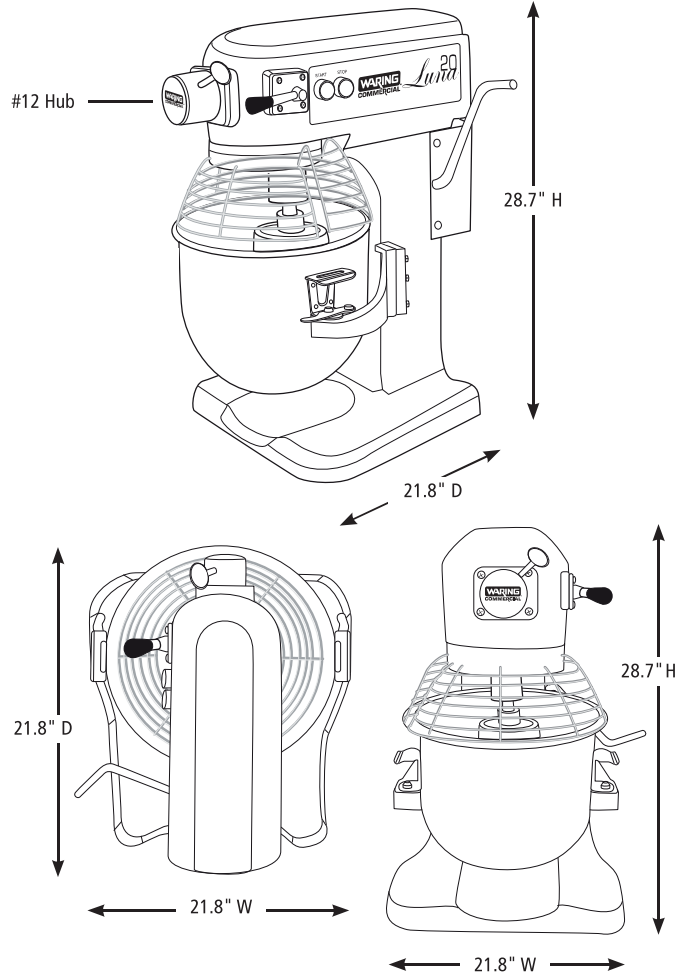

Out of Box Weight: 203 lb.

ORDERING INFORMATION	#STD. PKG.	GIFTBOX WEIGHT	CUBIC FEET	BOX DIMENSIONS D X W X H	UPC	CASE PKG.	MC WEIGHT	MC DIMENSIONS D X W X H	MBC
WSM20L – 20-Quart Planetary Mixer	1	229	11.5	24.625" x 22" x 36.875"	040072087837	1	229	24.625" x 22" x 36.875"	10040072087834



@waringcommercial

©2019 Waring Commercial  
314 Ella T. Grasso Avenue, Torrington, CT 06790  
Tel. 800-492-7464 • Fax 860-496-9008

waringcommercialproducts.com

19WC064945/ REV 09/19