



AMERICAN EAGLE[®]
FOOD MACHINERY, INC.

AE-40PA
40 Quart Floor Standing
Planetary Mixer

773.376.0800 (P) • 773.376.2010 (F) • 3131 S. Canal St. Chicago, IL 60616

Lower Your Total Cost Of Ownership With American Eagle[®] Mixers! All-Inclusive Accessories, Competitive Pricing, And Reliability Make Us The Value Leader In The Industry.

Quality Design

- Powerful 1.5 HP Motor
- Heavy Duty, Heat Treated Steel Alloy Shafts Handle Dough With Ease
- Durable, Precision Milled 100% Gear-Driven Transmission
- Heavy Duty, Rigid Cast Iron Body Construction
- Industry Standard #12 Hub For Additional Attachments
- Enamel Coating Resists Rust, Scratches, And Dents
- Non-Slip Rubber Feet For Extra Stability
- ETL Certified To Conform To NSF/ANSI 8, CSA, CE Standards



Standard Accessories

- High Polish 40 Quart Stainless Steel Bowl
- Aluminum Alloy Dough Hook
- Stainless Steel Wire Whip
- Aluminum Beater (Paddle)



Standard Features

- 15 Minute Automatic Timer
- 3 Fixed Speeds
- Safety Guard With Auto-Shutoff
- Thermal Overload Protection With Reset
- 1 Year Limited Warranty*

Optional Accessories

- AE-G12NH Meat Grinder Head
- AE-VS12NH Vegetable Processor
- AE-TS12H Meat Tenderizer Head
- AE-JS12H Jerky Slicer Head
- AE-MC12NH Meat Cutter Head

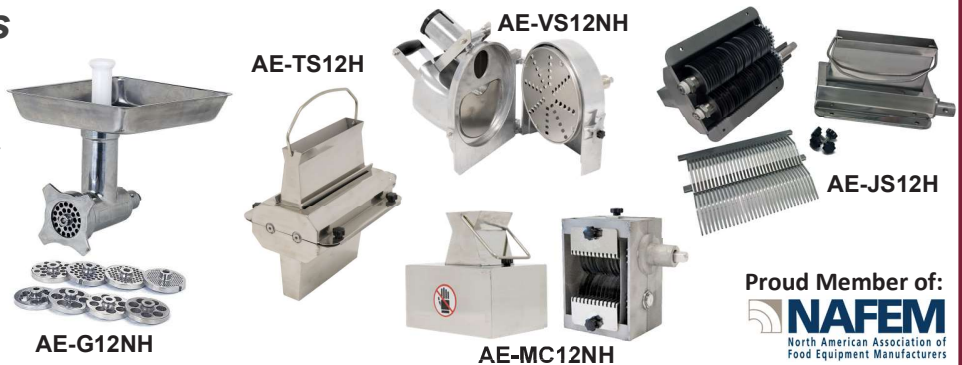

Proud Member of:
NAFEM
 North American Association of
 Food Equipment Manufacturers

Quality • Value • Reliability



AMERICAN EAGLE[®]
FOOD MACHINERY, INC.

AE-40PA
40 Quart Floor Standing
Planetary Mixer

sales@ameagle.biz • www.americaneaglemachine.com

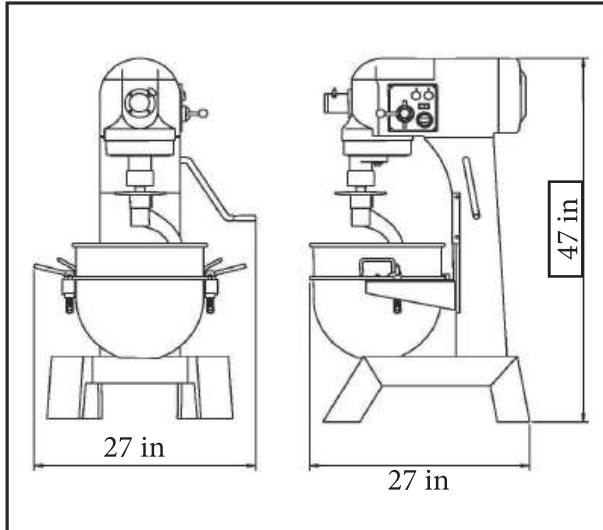

Other Available Sizes:

- AE-10NA 10 Quart Planetary Mixer
- AE-20NA 20 Quart Planetary Mixer
- AE-30NA 40 Quart Planetary Mixer
- AE-60N4A 60 Quart Planetary Mixer
- AE-80N4A 80 Quart Planetary Mixer (Special Order Only)

Specifications

Model	Capacity	Motor	Voltage V/HZ/PH	Amps	Transmission	Agitator Speeds (RPMs)**	Safety Guard	Timer	Power Bowl Lift
AE-40PA	40 Quarts Max 25 lbs. of flour* (60% absorption ratio)	1.5 HP	220/60/1	10	Gear Driven	1st: 152 2nd: 313 3rd: 573	Yes	Yes (15 min)	No

Optional AE-G12NH Meat Grinder Attachment

- 100% Stainless Steel Construction
- Includes Feeder Pan, Knife, Sausage Stuffer, Meat Pusher, 1/4" Plate, 5/16" Plate
- Meat Grinder Plate Sizes Available: 1/16" (2mm), 5/32" (4mm), 1/4" (6mm), 5/16" (8mm), 3/8" (10mm), 1/2" (12mm), 9/16" (14mm), 5/8" (16mm), 11/16" (18mm), Stuffing Plate (0mm)

Optional AE-VS12NH Vegetable Processor Attachment

- Polish Cast Aluminum Construction
- Dual Hopper Chamber Accommodates Large Variety Of Items
- Available Slicer Plate Adjusts to: 1/16" (No Spacer), 1/8" (Thin Spacer), 3/16" (Thick Spacer)
- Shredder/Grating Plate Sizes Available: 5/16", 1/4"

Dimensions and Shipping Information

Model	Overall Dimensions	Foot Print	Net Weight	Shipping Dimensions***	Ship Weight	Freight Class
AE-40PA	27"W x 27"L x 47"H	24"W x 24"D	440 lbs.	32 "W x 28"L x 56"H	523 lbs.	85

*Warranty must be registered. Refer to capacity guide in manual. Use of high speed with dough or improper speed change will void warranty. Extended Warranty available at extra cost.

**To change speeds, first turn off the machine. Move the lever into position so that the gears lock, then resume mixing.

***Crates are affixed to a skid (pallet). The weight and dimensions of this skid are included above and may vary from shipment to shipment.



Quality • Value • Reliability