

SPEC SHEETS

MODEL: SSF-39-2S

Vertical Reach In Freezer



Product features

- Digital Temperature Controller with automatic defrost function
- Includes six electrostatically painted shelves
- Corrosion Resistant stainless steel exterior and interior
- Eco-Friendly R-290 Refrigerant
- Self Closing doors
- Door Locks
- Heavy duty Casters
- LED Lighting
- Safety and Sanitation Listed



Available Color

Stainless steel

Accessories

- Steel Shelves

Product Highlights



Digital Temperature Controller



Heavy Duty Casters



Electrostatically painted Shelves

Certifications



Warranty

- 2 year parts and labor
- Additional 3 year compressor coverage

Residential: Assumes on liability for parts or labor coverage for component failure, factory defect or any other damages for units installed in non-commercial foodservice or residential applications.

PRODUCT SPECIFICATIONS

MODEL: SSF-39-2S



Plan view

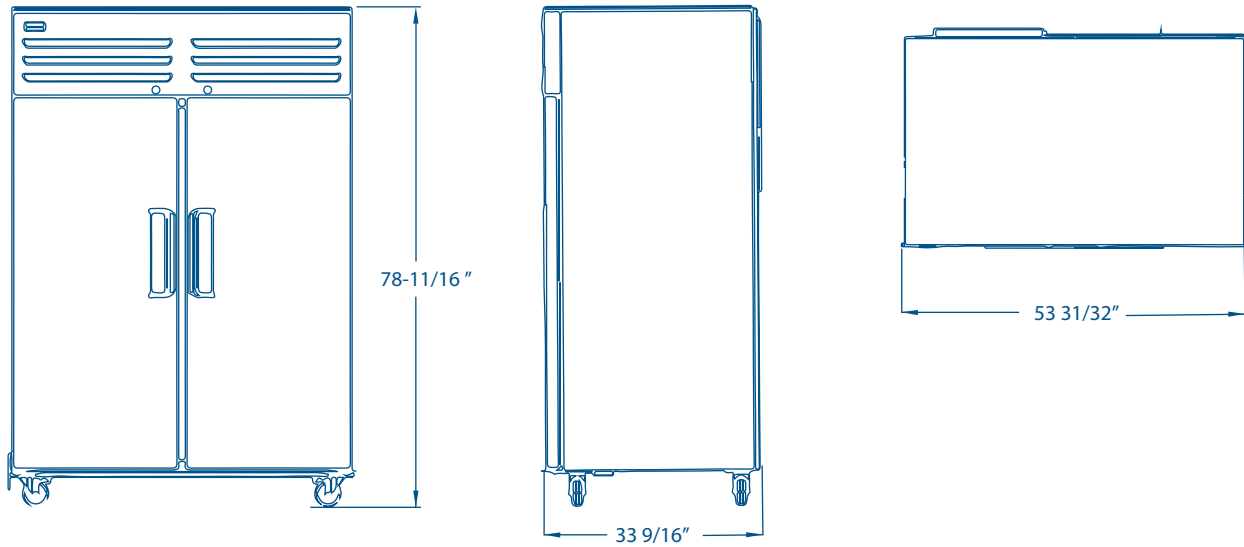

Technical data

Dimensions

External dimensions	W:53 31/32" D:33 9/16" H:78 11/16"
Internal dimensions	W:48 17/64" D:26 5/8" H:52"
Net volume	27.55 ft ³ 780 L
Net weight	437 lbs
Gross weight	492 lbs
Shelves Dimensions	W: 22 15/16" D:23 5/16"

Performance data

Refrigerant charge	5 oz (two systems)
Energy consumption	10.06 kW/24Hrs
Evaporator	Forced ventilation
Expansion method	Capillary
Thawing method	Electric

Construction

Exterior material	Stainless steel and Galvanized steel
Interior material	Stainless steel
Number of shelves	6
Shelf material	Electrostatically painted steel
Door type	Solid (Stainless steel)
Door quantity	2

Electrical data

Power supply	115V/ 60 Hz
Amps	8.5 A
Length of cord	118" (3200mm)
Lighting	LED
Plug type	NEMA 5-15P
Controller	Electric
Compressor power 1	1/2 HP / 1,060 W
Compressor power 2	1/3 HP / 841 W

Cooling

Equipment operating range	77 to 100.4 °F (25 to 38°C)
Controller temperature range	-4.0 to -0.4 °F (-20 to -18°C)
Set Point	-4.0 °F (-20°C)
Cut In	-0.2 °F (-17.88°C)
Cut Out	-4.0 °F (-20°C)
Refrigerant	R290
Condenser	Wire and tube

Logistic data

Trailer Loads	26 fit on a 53' trailer
Trailer Loads	23 fit on a 48' trailer
Unit weight with packaging	492 lbs
Dimensions with packaging	W: 60" D: 37 3/4" H: 82 1/4"