

DESIGNER LINE DISPLAY PASS-THRU WARMER

Model: DL1WE-PT-HD-GD-SD *Designer Line*

1-Section Display Extra-Wide Pass-Thru Warmer with Half Glass Doors on Front, Half Solid Doors on Rear

DL1WE-PT-HD-GD-SD - Stainless steel front, aluminum end panels and interior
DL1WE-SA-PT-HD-GD-SD - Stainless steel exterior, aluminum interior
DL1WE-SS-PT-HD-GD-SD - Stainless steel exterior and interior



Options and Accessories

(upcharge and lead times may apply)

Additional epoxy coated steel shelves	Special electrical requirements (consult factory)
Stainless steel shelves	Adjustable legs and Caster options
Wine rack	Rehinging of doors (consult factory)
Pan slide assemblies	Custom laminates

Consult factory for other model configurations, options and accessories.



Project Name:

Model Specified:

Location:

Item No: **Quantity:**

AIA #: **SIS #:**

Standard Model Features

HEATING SYSTEM

- Self contained, performance rated heating system
- 90°F to 180°F temperature range
- Top mounted heating plenum “plug” with circulating fan
- Unique air flow distribution ducts

CABINET ARCHITECTURE

- 3” non-CFC polyurethane foam insulation
- Smooth, polished chrome workflow door handles
- Triple-pane, tempered hinged glass doors
- Cam action, lift off hinges
- Self-closing doors
- Magnetic snap in Santoprene™ door gaskets
- Cylinder lock in each door
- Heavy duty, chrome plated steel shelves
- Heavy duty pilaster strips
- Adjustable 6” stainless steel legs

MODEL FEATURES

- Automatic interior lighting
- Electronic controller with digital display & hi-low alarm
- Stainless steel strip heaters located in base of interior

APPROVAL:

Model Specifications

DIMENSIONAL DATA

Net Capacity (cubic feet)	22 (623 l)
Width, Overall (inches)	28 1/2 (724 mm)
Depth, Overall (inches) (including handles)	38 3/4 (984 mm)
Depth (inches) (less doors)	32 (813 mm)
Depth (inches) (doors open 90°)	84 (2134 mm)
Clear Door Width (inches)	21 7/8 (556 mm)
Clear Half Door Height (inches)	27 1/2 (699 mm)
Height, Overall (inches) (including 6" legs)	83 1/4 (2115 mm)
Number of Doors	4
Number of Shelves	3
Shelf Area (square feet)	22.2 (2.1 sq m)
Tray Slide Capacity (top section)	9
Tray Slide Capacity (bottom section)	6

ELECTRICAL DATA

Voltage	208-230/60/1
Feed Wires (including ground)	3
Total Amps (International)	7.2 (7.2)
Total Wattage @ 208-230 volts	1500
10 ft. Cord/Plug (International)	No (No)

SHIPPING DATA

Height - Crated (inches)	85 1/2 (2172 mm)
Width - Crated (inches)	31 5/8 (803 mm)
Depth - Crated (inches)	42 (1067 mm)
Volume - Crated (cubic feet)	65 (1841 cu l)
Weight Std - Crated (pounds)	300 (137 kg)
Weight SS - Crated (pounds)	300 (137 kg)

Figures in parentheses reflect metric equivalents rounded to the nearest whole unit.

Model Plan Views

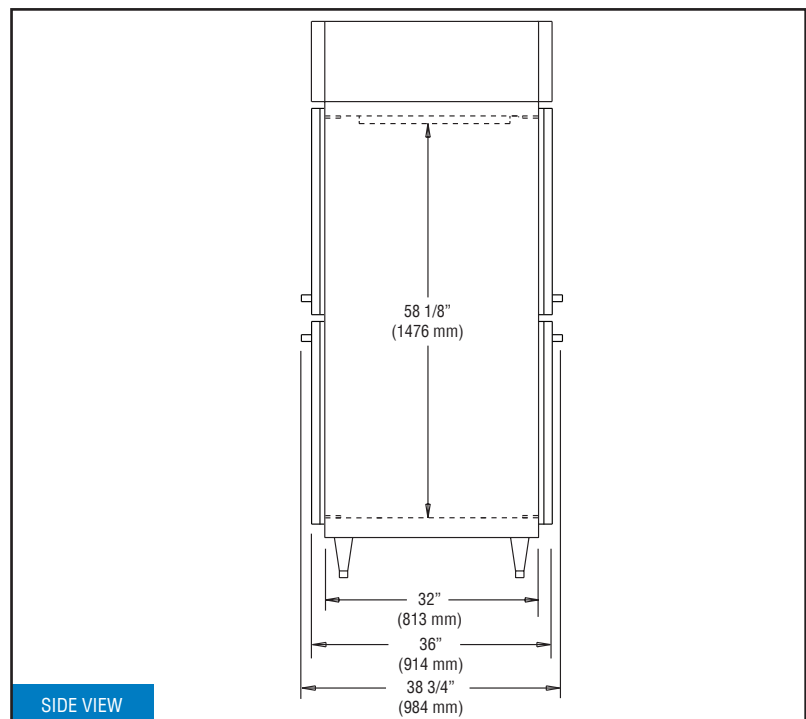
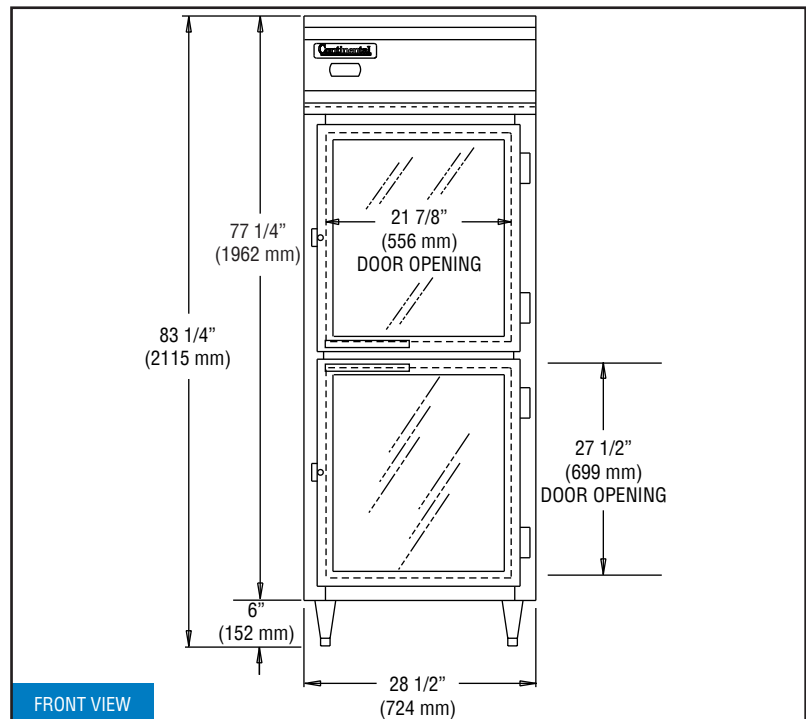

IMPORTANT NOTE: If the cabinet is located directly against a wall and/or under a low ceiling, a minimum clearance of 12" is required on top and 3" on sides and rear.

Continental
Refrigerator

Toll-Free: 800-523-7138
Phone: 215-244-1400
Fax: 215-244-9579

539 Dunksferry Road
Bensalem, PA 19020
www.continentalrefrigerator.com

Due to our continued efforts in developing innovative products, specifications subject to change without notice.



PROUDLY
DESIGNED & ASSEMBLED
IN THE U.S.A.

Intertek

© Copyright 2021. Continental Refrigerator.
A Division of National Refrigeration & Air Conditioning Products, Inc.

REVISED: 6/19/25