



Drago America
www.dragoamerica.com

Project Name: _____

SIA #

Location: _____

Item #: _____ Qty: _____

AIA #

Model #: _____

Model:
DRGF50

Coolers
12 ft³



Features & Benefits

Strong & Durable Structure

- Stainless steel top.
- Coated aluminum interior.
- Attractive corrosion resistant vinyl on steel in black finish on the exterior.

Temperature

- Temperature range 0°F ~ 7°F (-18°C ~ -14°C).

User Friendly Features

- Easy access to condenser coil for cleaning and service.
- Easy adjust temperature set point and defrost frequency.

Refrigerant R290.



Certifications



Intertek



Intertek

Lids	HP	AMPS	Crated Weight	Dimensions (inches)		
				W	D	H
2	1/2	5.3	224.8 Lb (102 Kg)	49.5" (1257 mm)	26.6" (675.6 mm)	34.3" (871.2 mm)

Packaging dimensions: W 55.1" (1400 mm) x D 32.6" (830 mm) x H 43" (1085 mm).

Approvals:

Available At:

Model:
DRGF50

Coolers

12 ft³



Plan View

Front View

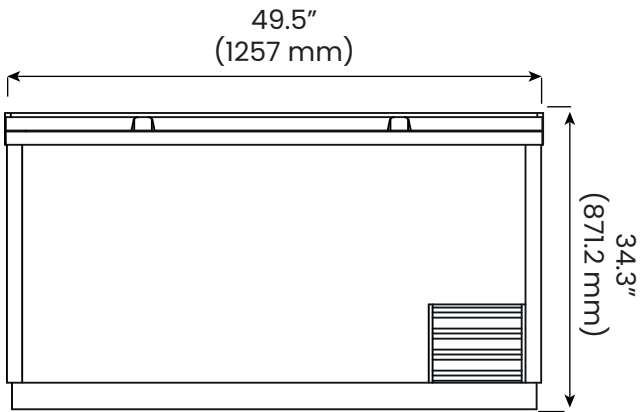

Side View

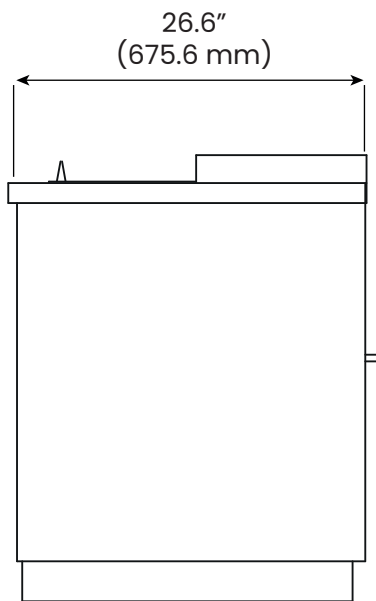

Spec

Electric Data

Voltage	115/60/1
Plug Type	NEMA 5-15P
Compressor HP	1/2
Refrigerant	R290

Dimensional Data

Capacity - cu. ft.	12 ft ³ (339.8 liters)
Net Weight - Lbs.	180.4 Lbs. (82 Kg)



Drago America
www.dragoamerica.com
(346) 374-8343
9777 W. Gulf Bank Road Suite 200, Houston, Texas 77040