



CURTIS G3 WATER FILTRATION SYSTEMS

MODELS: CSC5, CSC10, CSC15



Gourmet brewing begins with gourmet water.

- Simple, small profile filter head installation
- Selection of cartridges to handle any equipment type
- Quick disconnect style cartridge for easy replacement
- Proven HydroBlend™ scale and corrosion control PLUS chlorine taste and odor removal – Provides better tasting high quality beverages, reduced equipment maintenance costs, and increased equipment service life.

ITEM NO

PROJECT

DATE

Why worry about water?

The Scale is Tipped Against You.

Most water supplies contain high levels of scale-causing minerals (primarily calcium and magnesium) that build up on the heating elements, tanks, valves and other parts of your coffee brewing equipment. Excessive scale can cause increased service calls and complicate refurbishing of brewing equipment.

The Chlorine Connection.

Coffee is made up of 98% water. Consequently, the quality of the water greatly affects the quality of the brewed beverage. Municipal water supplies are treated with chlorine as a disinfectant. If not removed, the chlorine may react with the coffee, producing a bitter, unpleasant taste and odor.

The Clear Answer—CURTIS® Water Filtration Systems.

Curtis Water Filtration Systems are specifically designed for coffee brewing equipment. Advanced HydroBlend™ technology delivers effective scale and corrosion control, and enhanced filtration components provide superior chlorine taste and odor removal for a better tasting gourmet beverage. Plus, Curtis Filters feature an extra large filtration medium which provides proper water flow well past the recommended replacement cycle – eliminating clogged filters and unnecessary service calls.

Engineered for the Rigors of High Temperature Brewing.

Most filters are designed for cold water applications. The HydroBlend™ technology used in Curtis Water Filtration Systems, is engineered to excel under high temperature conditions, providing unparalleled scale control for your brewing equipment.

Simply The Best Solution.

Both user-friendly and economical, Curtis Water Filtration Systems are your best insurance to protect your valuable investment and provide consistent high quality results. Use of a Curtis Filtration System practically guarantees reduced service calls while simplifying refurbishing programs. And, Curtis G3 equipment provides an automatic reminder when filters should be replaced through its programmable P-Maintenance feature.

Don't Water Down Your Profits.

Offer your customers the very best brew possible and insure your quality coffee brewing equipment investment with a quality water filtration system. Curtis® Water Filtration Systems.



Installation and Replacement is Simple!

- 1. Unpack the water filter system.** – Components include filter cartridge and head with mounting bracket.
 - 2. Locate space for filter installation.** – For wall mounting allow 2" space under filter for cartridge removal.
 - 3. Make connection to feed head using 3/8" Male NPT connectors.** – (Do not over tighten! If using a brass compression fitting, use a back up wrench when tightening the compression nut.)
 - 4. Install the cartridge into the head.** – Line up the posts in the filter head with the grooves on the cartridge. Push upward into the head until it seats, then turn clockwise 1/4 turn until the filter stops.
- To remove** – turn counter-clockwise 1/4 turn until it stops then pull down and remove filter.

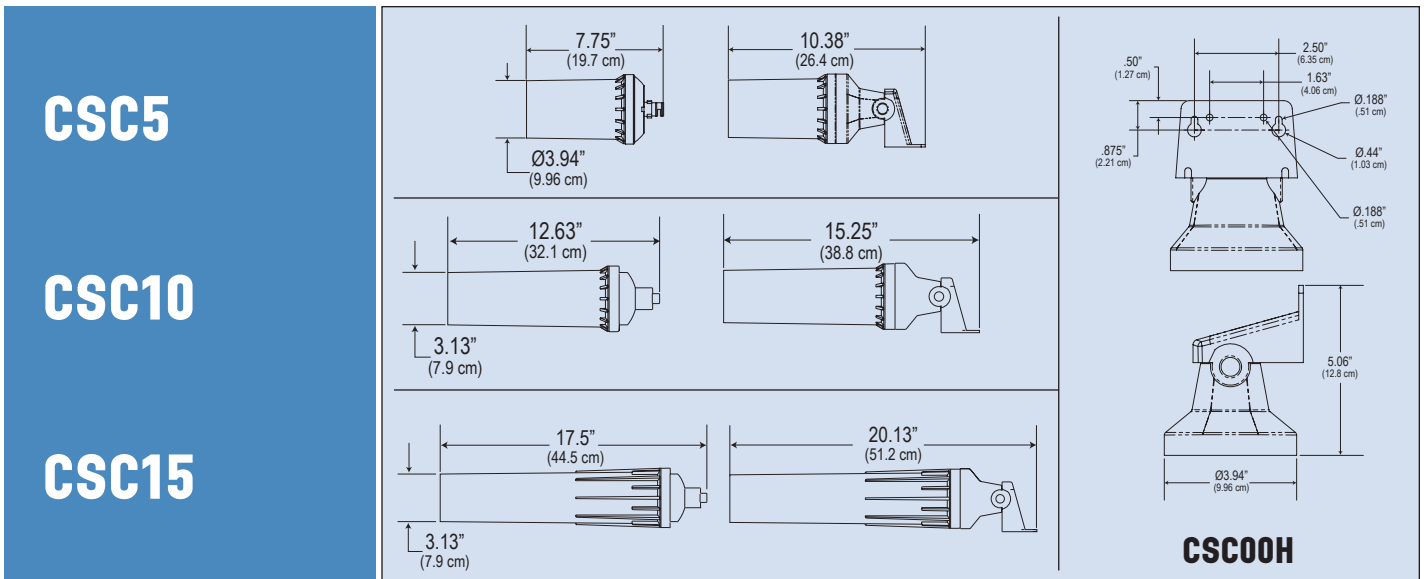

Specifications	Application/Description	Rated Life* (Gallons)	Flow (GPM)	Micron Rating	Pressure Range (psi)	Temperature Range (°F)	Water Connection	Ship Wt. ** (lbs.)	Cube. ** (cu. ft.)
CSC5AC00 with Head	Chlorine & Sediment Removal, Scale Prevention	4,000	.75	10	35-125psi	35-100°F	3/8" FNPT	11	1.36
CSC5CC00 Cartridge Only	Chlorine & Sediment Removal, Scale Prevention	4,000	.75	10	35-125psi	35-100°F		9	1.36
CSC10AC00 with Head	Chlorine & Sediment Removal, Scale Prevention	10,000	1.65	10	35-125psi	35-100°F	3/8" FNPT	17	1.23
CSC10CC00 Cartridge Only	Chlorine & Sediment Removal, Scale Prevention	10,000	1.65	10	35-125psi	35-100°F		15	1.23
CSC10AV00 with Head	Chlorine & Sediment Removal, Scale Prevention/OCS/VEND	10,000	1.65	10	35-125psi	35-100°F	3/8" FNPT	17	1.23
CSC10CV00 Cartridge Only	Chlorine & Sediment Removal, Scale Prevention/OCS/VEND	10,000	1.65	10	35-125psi	35-100°F		15	1.23
CSC10CC01 Cartridge Only	Chlorine & Sediment Removal, Scale Prevention/CUNO Repl.	10,000	1.65	10	35-125psi	35-100°F		15	1.23
CSC15AC00 with Head	Chlorine & Sediment Removal, Scale Prevention	15,000	2	10	35-125psi	35-100°F	3/8" FNPT	23	1.69
CSC15CC00 Cartridge Only	Chlorine & Sediment Removal, Scale Prevention	15,000	2	10	35-125psi	35-100°F		21	1.69
CSC15CC01 Cartridge Only	Chlorine & Sediment Removal, Scale Prevention/CUNO Repl.	15,000	2	10	35-125psi	35-100°F		21	1.69
CSC10CF00 Cartridge Only	Chlorine Removal, Scale Prevention, Extra Sediment Loading	5,000	1	10	35-125psi	35-100°F		15	1.23
CSC15CF00 Cartridge Only	Chlorine Removal, Scale Prevention, Extra Sediment Loading	7,500	1.5	10	35-125psi	35-100°F		21	1.69

WC-37342 Kit, Filter Quick Change

*Rated Life is for Chlorine Removal. To ensure proper control of scale, filters should be replaced every 6 months.
 ** Shipping Weight and Cube are per cases of 6.



WILBUR CURTIS COMPANY, INC.
 6913 Acco Street, Montebello, CA 90640-5403
 Telephone: 800-421-6150 · 323-837-2300
 Fax: 323-837-2406
 www.wilburcurtis.com

