



ATLAS METAL

1135 N.W. 159th DRIVE, MIAMI, FLORIDA 33169

TEL 305.625.2451

TOLL FREE 800.762.7565

FAX 305.623.0475

WWW.ATLASFOODSERV.COM

SALES@ATLASFOODSERV.COM

HOT/COLD PAN - WQHC SERIES

Service and Installation Manual

Please read this manual completely before attempting to install or operate this equipment!
Notify carrier of damage! Inspect all components immediately. See page 1.



DROP-IN HOT/COLD PAN (3"
RECESSED TOP) DUAL TEMP.
HOT OR COLD SERVICE



Effective Date: 2021
IMPORTANT INFORMATION
READ BEFORE USE

CONTENTS

RECEIVING & INSPECTING EQUIPMENT.....	1
SERIAL AND MODEL # LOCATION.....	1
WQHC SPECIFICATIONS, FEATURES AND ACCESSORIES.....	2
OVERALL DIMENSIONS, ELECTRICAL CHARACTERISTICS AND CUT-OUT REQUIREMENTS.....	3
PARTS LIST.....	4
INSTALLATION, OPERATION AND S/S MAINTENANCE.....	5,6
ELECTRICAL SCHEMATICS.....	7,8,9,10,11
LIMITED WARRANTY.....	12
WARRANTY INFORMATION.....	13

RECEIVING AND INSPECTING THE EQUIPMENT

1. VISUALLY INSPECT THE SHIPPING CRATE. DAMAGE SHOULD BE NOTED AND REPORTED TO THE DELIVERING CARRIER.
2. IF DAMAGED, OPEN AND INSPECT CONTENTS WITH CARRIER.
3. IF CRATE IS NOT DAMAGED AND THERE IS CONCEALED DAMAGE TO THE EQUIPMENT, NOTIFY THE CARRIER. NOTIFICATION MUST BE MADE VERBALLY AND IN WRITING.
4. REQUEST AN INSPECTION BY THE SHIPPING COMPANY FOR THE DAMAGED EQUIPMENT WITHIN 10 DAYS FROM RECEIPT OF THE EQUIPMENT
5. FREIGHT CARRIERS CAN SUPPLY THE NECESSARY FORMS ON REQUEST.
6. SAVE ALL CRATING MATERIALS UNTIL INSPECTION HAS BEEN MADE OR WAIVED.

SERIAL NUMBER LOCATION

THE SERIAL AND MODEL# CAN BE FOUND ON THE CONDENSING UNIT ENCLOSURE - SEE OPERATORS SIDE CONTROL PANEL WHEN CALLING ATLAS FOR PARTS AND SERVICE. ALWAYS HAVE THIS INFORMATION AVAILABLE.

SERIAL #: _____

MODEL #: _____

INSTALLATION DATE: _____



ATLAS METAL

1135 N.W. 159th DRIVE, MIAMI, FLORIDA 33169

TEL 305.625.2451

TOLL FREE 800.762.7565

FAX 305.623.0475

WWW.ATLASFOODSERV.COM

SALES@ATLASFOODSERV.COM

Project: _____

Item No.: _____

Quantity: _____

DROP-IN SERVING EQUIPMENT

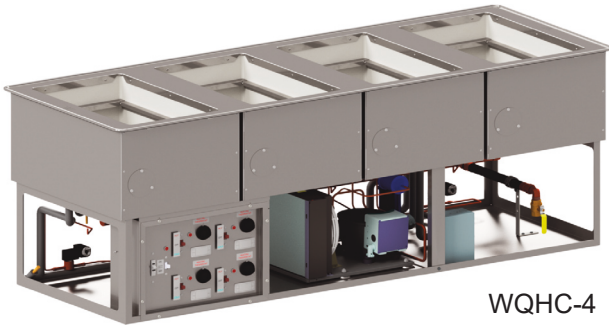

WQHC-4

HOT/COLD PAN

(3" Recessed Top)

Dual Temp.

Hot or Cold Service

WQHC-1

WQHC-2

WQHC-3

WQHC-4

SPECIFICATIONS

TOP: Constructed of 18 gauge, type 304 stainless steel, die stamped with a raised perimeter bead. There shall be a solid vinyl gasket under the beaded edge to form a seal to the counter top, thus preventing seepage or marring of the counter top. Embossed mounting lugs are provided along the inner surface, 3" down from the top, to hold the pan rails and a full set of removable separator channels in place.

LINER: The inner liner shall be 18 gauge, type 304 stainless steel, one piece construction, all welded, ground and polished to a uniform finish. All corners are covered with a minimum 1/4" radius. The liner has copper tubing firmly soldered to the top 3" on all sides. A 3/4" dia. drain with strainer, 4" copper nipple, and valve is provided.

INSULATION: Each pan is fully insulated with high density fiberglass, 1-1/2" thick on all sides, 2" thick on the bottom and enclosed with 22 gauge galvanized steel outer case.

HEATING ELEMENT: Individual wells shall be 18 gauge, type 304 stainless steel, one piece construction, all welded, ground and polished to a uniform finish. All corners are covered with a minimum 1/4" radius. Each well is provided with an 850 watt heating element.

REFRIGERATION SYSTEM: The compressor housing shall be fabricated from galvanized formed angles and bolted to the base of the unit. A fully self-contained condensing unit is provided with a hermetically sealed compressor and a thermostat control. The system is fully charged with CFC free refrigerant and ready to operate.

NOTE: Proper ventilation must be provided in counter

ELECTRICAL: The unit is pre-wired with a hot/cold selector switch that prevents dual operation, with the required thermostat controls. The unit is provided with a 6' long, 3-wire cord and a twist lock plug.

Specifications subject to change without notice.

STANDARD FEATURES

- **Dual Temp:-** each pan is individually controlled. Unit can serve as a hot serving pan or a refrigerated pan. Serving operation can be mixed & matched.
- **Factory applied gasket -** makes installation a snap and seals units to the counter top, thus eliminating seepage
- **Accommodates standard 12" X 20" pans or fractional size pans** with the use of optional adapter bars
- **1-Year Parts & Labor Warranty**
- **RDVE - Rear Drain Valve Extension**

ACCESSORIES

- **5YW - 5-Year Compressor Warranty**
- **Stainless Steel adapter plates** (pgs. DI-51-52)
- **CP - Cover Plate with handles, S/S**

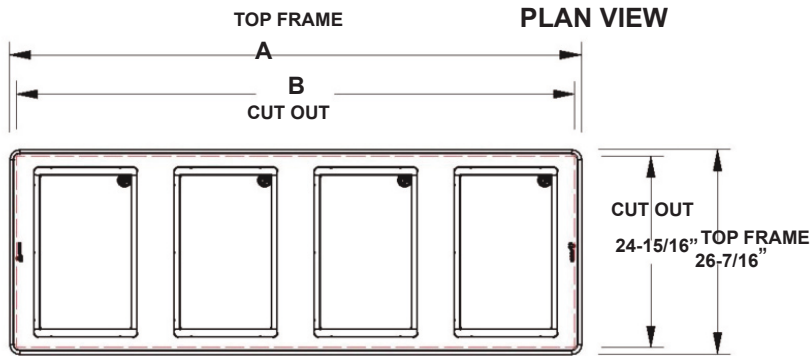

OVERALL DIMENSIONS

UNIT	A	B	C
WQHC-1	19-5/8"	17-15/16"	17-13/16"
WQHC-2	37-7/8"	36-1/16"	35-7/8"
WQHC-3	56"	54-1/4"	54"
WQHC-4	74-1/8"	72-9/16"	72-1/8"

SIDE VIEW

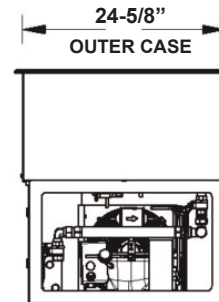
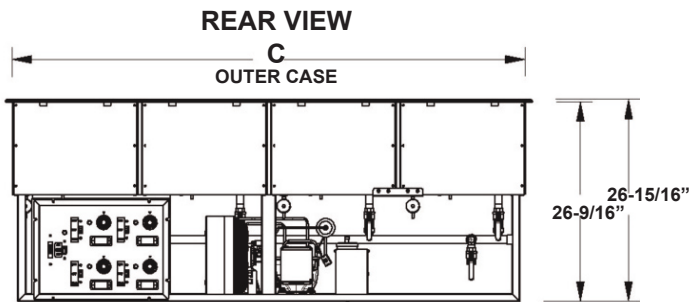

MODEL	"A"	PAN SIZE	ELECTRICAL CHARACTERISTICS		NEMA CONFIGURATION	SHIP WT. (LBS.)
			HOT OPERATION	COLD OPERATION		
WQHC-1	19-5/8" (48.26cm)	(1)19-7/8" X 11-7/8" X 9" (50.4cm X 30.16cm X 22.86cm)	7.4 amps. - 0.85KW - 120V 4.1 amps. - 0.85KW - 208V 3.5 amps. - 0.85KW - 240V	4.2 amps - 1/4HP - 120V	5-15P L14-20P I 14-20P	
WQHC-2	37-7/8" (96.20cm)	(2)19-7/8" X 11-7/8" X 9" (50.4cm X 30.16cm X 22.86cm)	14 amps. - 1.7KW - 120V 8.2 amps. - 1.7KW - 208V 7.1 amps. - 1.7KW - 240V	6.2 amps - 1/4HP - 120V	5-20P L14-20P I 14-20P	
WQHC-3	56" (142.24cm)	(3)19-7/8" X 11-7/8" X 9" (50.4cm X 30.16cm X 22.86cm)	21.3 amps. - 2.55KW - 120V 12.3 amps. - 2.55KW - 208V 10.6 amps. - 2.55KW - 240V	6.5 amps - 1/3HP - 120V	L5-30P L14-20P I 14-20P	
WQHC-4	74-1/8" (188.27cm)	(4)19-7/8" X 11-7/8" X 9" (50.4cm X 30.16cm X 22.86cm)	16.3 amps. - 3.4KW - 208V 14.2 amps. - 3.4KW - 240V	10.7 amps - 3/4.HP - 120V	L14-30P L14-20P	

*Units are wired to prevent simultaneous operation in the hot and cold mode.

PAN OPENINGS	COUNTER CUT-OUT REQUIRED	"C"
1	24-15/16 X 17-15/16" (60.96 X 43.18 cm)	17-13/16" (43.18cm)
2	24-15/16 X 36-1/16" (60.96 X 91.44 cm)	36" (91.44cm)
3	24-15/16 X 54-1/4" (60.96 X 137.16cm)	54-3/4" (139.7cm)
4	24-15/16" X 72-9/16" (60.96 X 182.88cm)	72-5/16" (182.88cm)



ATLAS METAL

Subsidiary of Mercury Aircraft, Inc.

1135 N.W. 159th DR., MIAMI, FL 33169

PHONE (305) 625-2451, (800) 762-7565, FAX (305) 623-0475, E-mail: sales@atlasfoodserv.com

PARTS LIST HOT OR COLD COMBINATION UNIT WQHC SERIES

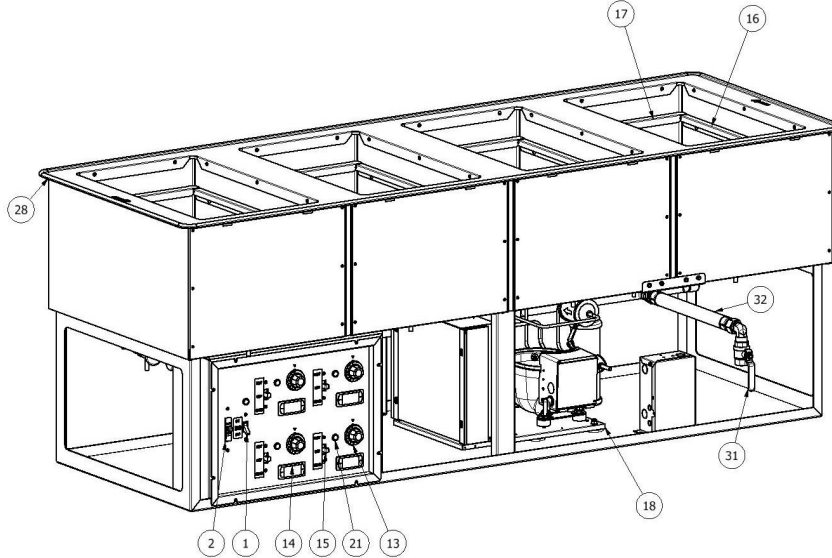

ITEM NUMBER	PART NUMBER	DESCRIPTION
1	12-202	Master Switch 30 Amp-2P
2	1118-1101	Circuit breaker 15 AMP
3	2687-9	Twist Plug L14-20P (not shown)
3.1	2691-3	Twist Plug L14-30P (not shown)
3.2	12-256	Twist Plug L5-30P (not shown)
4	1006-2	Power Cord #14-3 120V w/plug NEMA 5-20P (not shown)
4.1	1004-3	Power Cord #12-3 120V w/plug (not shown)
4.2	1011	Power Cord #14-4 120/208-240V (not shown)
4.3	1004-5	Power Cord #12-4 120/208-240V (not shown)
5	600012	3/8" Romex Connector (not shown)
6	10924	1/2" Connect Conduit (not shown)
7	1092-5	1/2" Bush short AS350(not shown)
8	1092-2	1/2" Flexible Conduit (not shown)
9	1800-3012	Terminal block (not shown)
10	1111-21	Levernuts 2P splicing (not shown)
	1111-22	Levernuts 3P splicing (not shown)
	1111-23	Levernuts 5P splicing (not shown)
11		Relay 120V 30 Amp (not show)
12	1096-96	Hot Thermostat (not show)
13	1097-2	Thermostat Knob
14		Cold Electronic Thermostat
15	112-1252	Manual Control Switch 15 AMP

ITEM NUMBER	PART NUMBER	DESCRIPTION
16	S86104-0	Insert side
17	S86105-0	Insert front & back
18	2029-16M6	1/3 HP Compressor (not shown) (WQHC-3)
	2029-11M6	1/4 HP Compressor (not shown) (WQHC-2)
	2029-13M6	3/4 HP Compressor (WQHC-4)
19	1053-HT	120V-850W Heat Element (not shown)
	1054-HT	208V-850W Heat Element (not shown)
	1055-HT	240V-850W Heat Element (not shown)
20	S81114-0	Element Holder (not shown)
21	1100	Red Pilot Light
22	1800-3917	Solenoid Valve (not shown)
23	1800-3918	Solenoid Coil (not shown)
24	22-100	Safety Switch Control (not shown)
25	494-56	1/16 Expansion Valve (not shown)
26		Suction Accumulator A-AS-384 (not shown)
27	S863202	Snap Drain (not shown)
28	7002	Bead Gasket
29	49-1028	Rubber Grommet (not shown)
30	3007-5	3/4" Brass Nipple (not shown)
31	30-403	3/4" Ind. Valve
32	30-29	Gas Hose Extension
33	30-11	3/4" Fitting Adaptor (not shown)

INSTALLATION

Provide the correct counter cut-out opening (see chart below), and drop in. The vinyl gasket assures complete seating. A non-toxic silicone seal may be used between the gasket and countertop (not required).

Note: Units are supplied with a nipple and stop valve to be connected for draining.

“Wastewater connections are to conform to the International Plumbing Code 2003, International Code Council (ICC) or the Uniform Plumbing Code 2003, International Association of Plumbing and Mechanical Officials (IAPMO)”, or the equivalent.

OVERALL DIMENSIONS			
UNIT	A	B	C
WQHC-1	19-5/8"	17-15/16"	17-13/16"
WQHC-2	37-7/8"	36-1/16"	35-7/8"
WQHC-3	56"	54-1/4"	54"
WQHC-4	74-1/8"	72-9/16"	72-1/8"

The unit should be level for draining purposes. When installing unit in a counter, it is recommended that the operator side of the counter be completely open for air circulation. When this is not possible, such as in an island counter, it is recommended that two grill openings be provided, approximately 18” x 18” of free air for intake and exhaust, at opposite ends of the counter, and a minimum clearance of 14” at the top, 24” at the back and 10” at each side of the enclosure.

The unit is supplied with a power cord and NEMA plug. Refer to the data plate on the compressor housing for the amperage and voltage information. Use a licensed electrician when installing power source.

OPERATION

HEATING OPERATION

Unit runs with water or without water

COOLING OPERATION

With-Water operation

- 1) Turn Master Switch to ON position
- 2) Turn Selector Switch to HOT
- 3) Close individual drain valves. (Red drain handles)
- 4) Fill the unit with water (preferably hot water) until the level assigned.
- 5) Turn the T-Stat to position # 10
- 6) Cover the well with a lid and wait 45 minutes for the unit to heat up.
- 7) Insert pans with food. Be cautious, unit is hot.
- 8) Check the water level every 2 hours.
- 9) To turn the unit off, switch all Select Switches from ON to OFF and set the Master Switch to OFF.

Dry operation (with-Out Water)

- Follow steps 1 to 3
- 4) Turn the T-Stat to position # 10
 - 5) Cover the well with a lid and wait 15 minutes for the unit to heat up.
 - 6) Insert pans with food. Be cautious, unit is hot.
 - 7) To turn the unit off, switch all Select Switches from ON to OFF and set the Master Switch to OFF.

1. Turn Master Switch to ON position
2. Turn Select Switch to COLD
3. Electronic Thermostat is automatically set from factory.
4. Cover well with a lid and wait 45 minutes for the unit to cool.
5. Insert pans
6. To turn the unit off, switch all Select Switches from ON to OFF and set the Master Switch to OFF.

HEATING TO COOLING OPERATION

1. Keep master switch in ON position.
2. Turn selector switch to COLD.
3. Electronic Thermostat will change temperatures automatically.
4. Open all drain valves (red and blue drain handles) to remove hot water completely and wait 40 minutes.
5. Close rear drain valve (blue drain handle)
6. The well will not operate until it has cooled. Please allow time for the well to cool.
7. Remove any hot operation serving material. (Pans, food, etc.)
8. Cover the well with a lid and wait 45 minutes for the unit to cool.
9. Insert pans
10. To turn the unit off, switch all Select Switches from ON to OFF and set the Master Switch to OFF.

COOLING TO HEATING OPERATION

1. Keep master switch in ON position.
2. Turn selector switch to HOT.
3. Electronic Thermostat will change temperatures automatically.
4. Close individual drain valves. (Red handles)
5. If using water, fill the unit with hot water to the marked level in the well.
6. Cover the well with a lid and wait 15 minutes to heat.
7. Insert pans
8. Check the water level every 2 hours.
9. To turn the unit off, switch all Select Switches from ON to OFF and set the Master Switch to OFF

MAINTENANCE

NEVER CLEAN PANS WITH A CHLORIDE, ALL-PURPOSE, BLEACH, ACIDIC, VINEGAR BASED PRODUCTS. CHLORIDES OR IMPROPER CLEANING COULD SCAR, MARK AND/OR CORRODE PANS. DO NOT USE STEEL WOOL OR ABRASIVE PRODUCTS TO CLEAN. USE SOAPY WARM WATER, RINSE THOROUGHLY TO REMOVE ALL RESIDUES. FAILURE TO MEET THESE CONDITIONS WILL VOID WARRANTY.

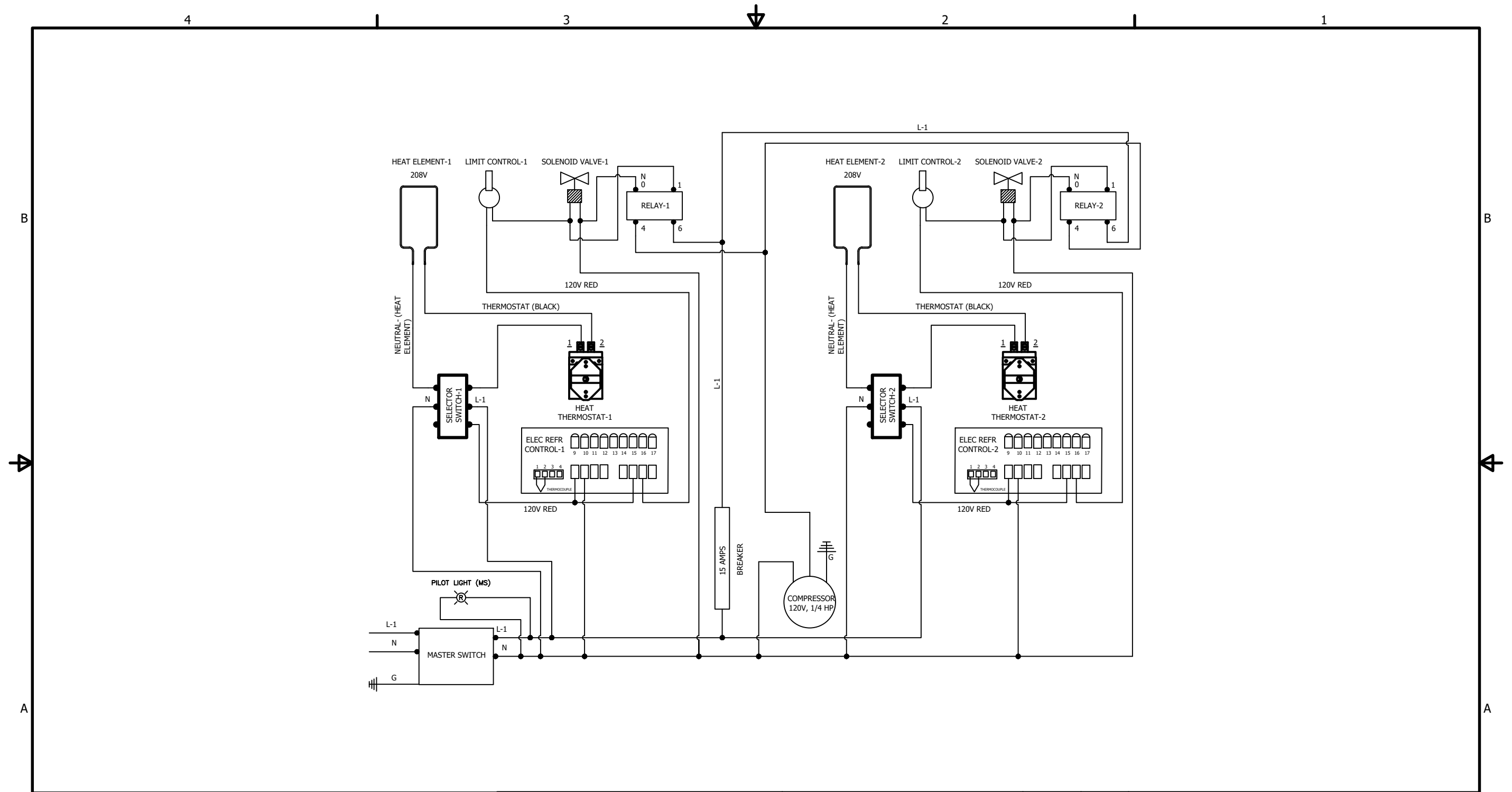

REVISION HISTORY			
REV	DESCRIPTION	DATE	BY
1			
2			
3			
4			
5			

These plans are the exclusive property of Atlas Metal Industries Inc. Any unauthorized use without written consent of Atlas Metal Industries Inc., is strictly prohibited.



DATE: 02.17.21	SIZE: B	CUSTOMER: WQHC-2
DRAWN BY: OGA		REFERENCE: 120V-1ph - 1/4 HP
CHECKED BY: ULLOA	P.O. #: -----	DRAWING No. -----
	JOB #: -----	SCALE: 3/4" = 1'-0" SHEET No. 1 OF 1

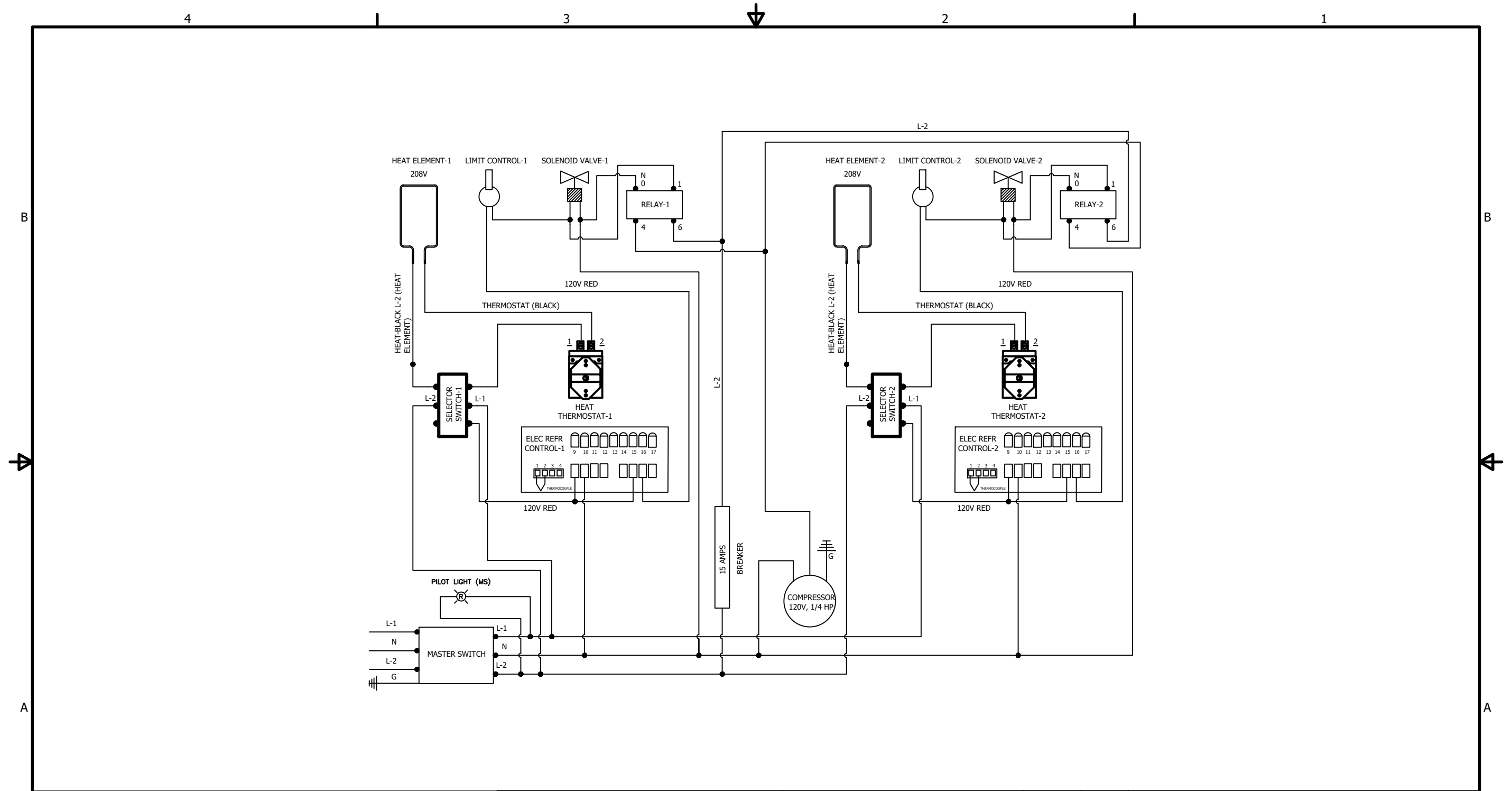

REVISION HISTORY			
REV	DESCRIPTION	DATE	BY
1			
2			
3			
4			
5			

These plans are the exclusive property of Atlas Metal Industries Inc. Any unauthorized use without written consent of Atlas Metal Industries Inc., is strictly prohibited.



DATE: 02.17.21	SIZE: B	CUSTOMER: WQHC-2	
DRAWN BY: OGA		REFERENCE: 120V/208V & 120V/240V -1ph - 1/4 HP	
CHECKED BY: ULLOA	P.O. #: -----	DRAWING No. -----	SCALE: 3/4" = 1'-0"
	JOB #: -----		SHEET No. 1 OF 1

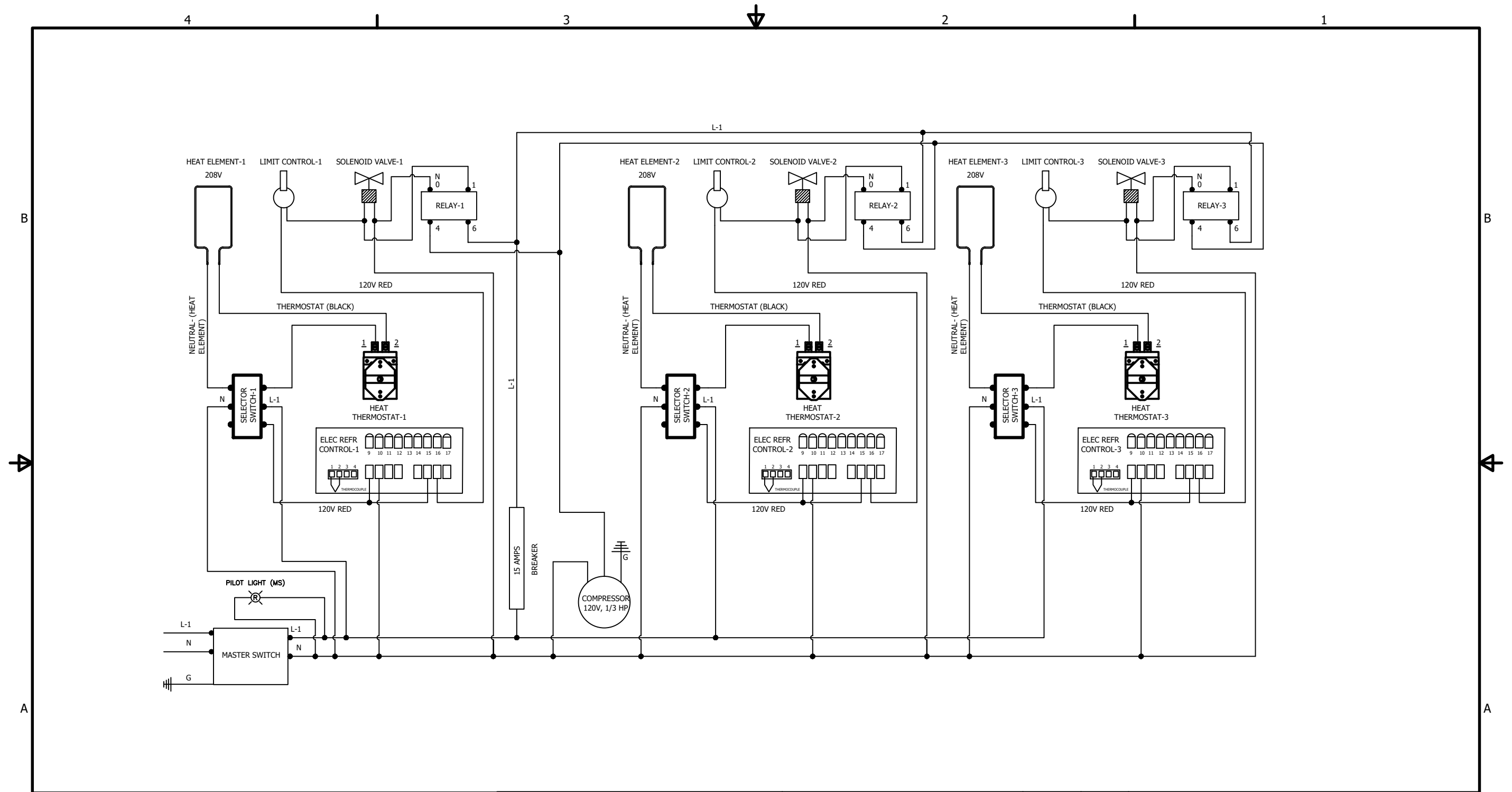

REVISION HISTORY			
REV	DESCRIPTION	DATE	BY
1			
2			
3			
4			
5			

These plans are the exclusive property of Atlas Metal Industries Inc. Any unauthorized use without written consent of Atlas Metal Industries Inc., is strictly prohibited.



DATE: 02.17.21	SIZE: B	CUSTOMER: WQHC-3	
DRAWN BY: OGA		REFERENCE: 120V-1ph - 1/3 HP	
CHECKED BY: ULLOA		P.O. #: -----	DRAWING No. -----
		JOB #: -----	SCALE: 3/4" = 1'-0" SHEET No. 1 OF 1

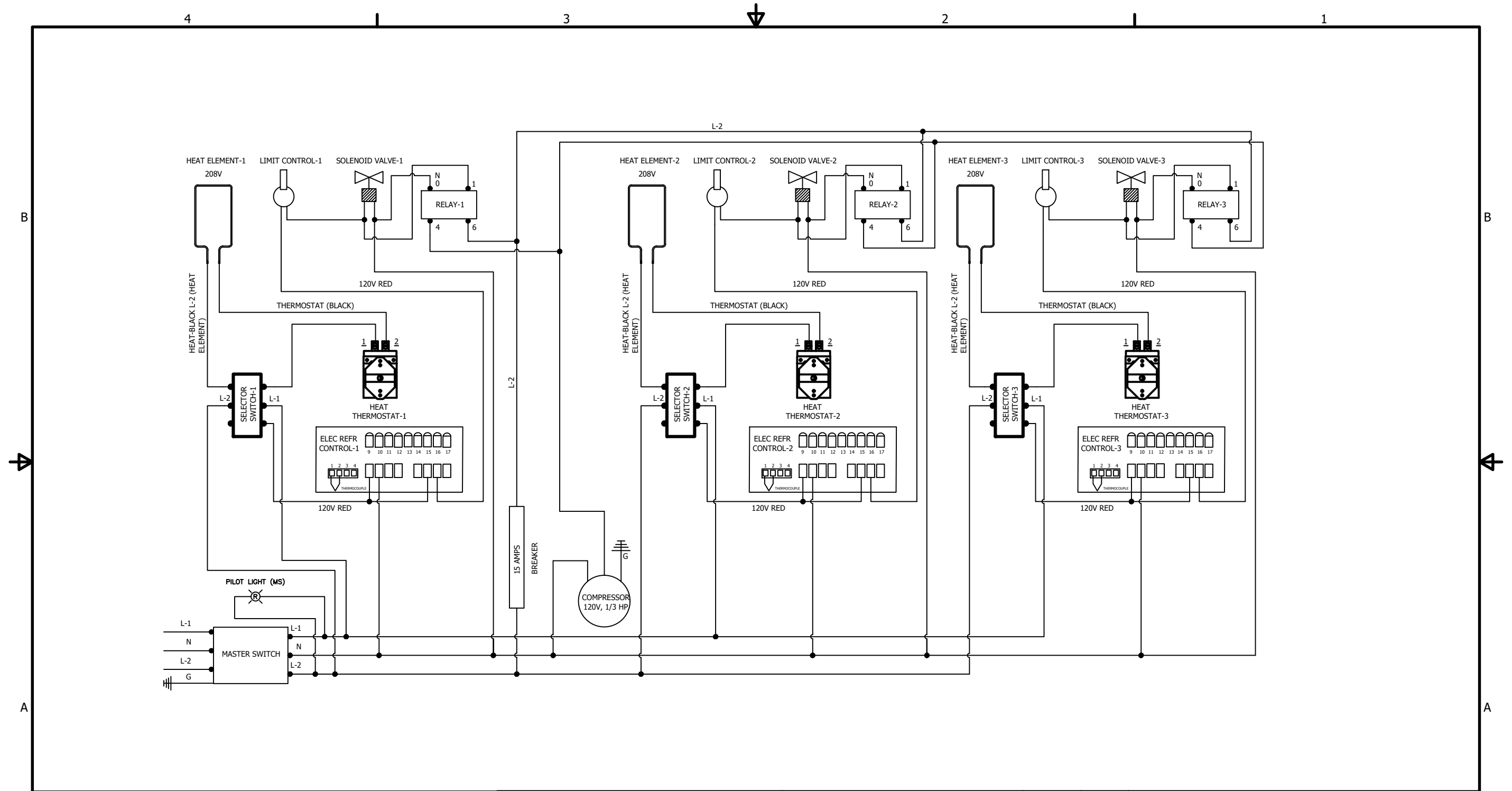

REVISION HISTORY			
REV	DESCRIPTION	DATE	BY
1			
2			
3			
4			
5			

These plans are the exclusive property of Atlas Metal Industries Inc. Any unauthorized use without written consent of Atlas Metal Industries Inc., is strictly prohibited.



DATE: 02.17.21	SIZE: B	CUSTOMER: WQHC-3	
DRAWN BY: OGA		REFERENCE: 120V/208V & 120V/240V -1ph - 1/3 HP	
CHECKED BY: ULLOA	P.O. #: -----	DRAWING No. -----	SCALE: 3/4" = 1'-0"
	JOB #: -----		SHEET No. 1 OF 1

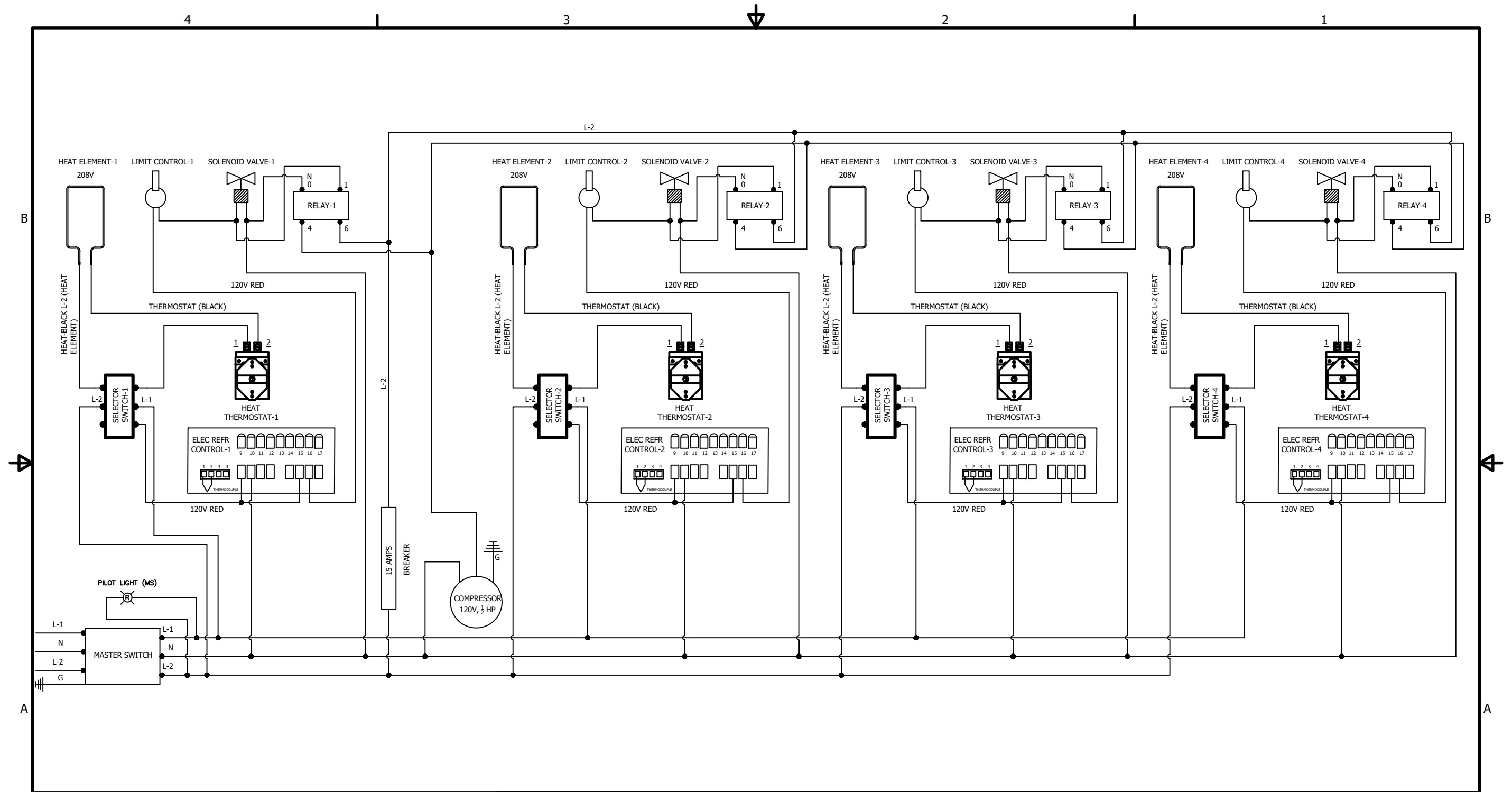

REVISION HISTORY			
REV	DESCRIPTION	DATE	BY
1			
2			
3			
4			
5			

These plans are the exclusive property of Atlas Metal Industries Inc. Any unauthorized use without written consent of Atlas Metal Industries Inc., is strictly prohibited.



DATE: 02.17.21	SIZE: B	CUSTOMER: WQHC-4	
DRAWN BY: OGA		REFERENCE: 120V/208V & 120V/240V -1ph - 3/4 HP	
CHECKED BY: ULLOA	P.O. #: -----	DRAWING No. -----	SCALE: 3/4" = 1'-0"
	JOB #: -----		SHEET No. 1 OF 1

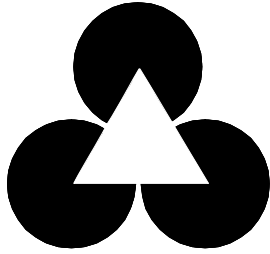

Atlas Metal
INDUSTRIES, INC.

LIMITED WARRANTY

Atlas Metal Industries, Inc. warrants to the Purchaser of this product that the same shall be free from defects in the workmanship and material for a period of one year from the date of original installation of the equipment, but not to exceed eighteen (18) months after date of shipment from factory. During this period of time Atlas Metal Industries, Inc. will replace all defective parts and will pay for authorized replacement labor. Replacement and installation of such parts and labor shall be provided only upon prior written authority of Atlas Metal Industries, Inc.

The Refrigeration warranty is for a twenty (20) month time period and includes supplying the compressor at a no charge basis provided the damage to the compressor was not caused by the customer or end user. Authorized replacement labor will be paid for a period of one year from date of installation. Freight costs for defective unit to and from Atlas Metal Industries, Inc. are not included, and all defective parts must be returned to the factory freight prepaid for evaluation. **ALL WARRANTY LABOR MUST BE AUTHORIZED BY ATLAS METAL INDUSTRIES, INC. PRIOR TO THE ACTUAL WORK BEING DONE.** This warranty does not apply to any equipment or any part thereof, which has been subjected to shipping damage, improper voltage, alteration, abuse or misuses, and does not cover loss of food, other products, or damage to property due to mechanical or electrical malfunction.

THERE ARE NO WARRANTIES WHICH EXTEND BEYOND THE DESCRIPTION OF THE FACE HEREOF. SELLER DISCLAIMS ANY IMPLIED WARRANTY OF MERCHANTABILITY OF THE GOODS OR THE FITNESS OF THE GOODS FOR ANY PURPOSE AND BUYER AGREES THAT THE GOODS ARE SOLD "AS IS."

THIRD PARTY EQUIPMENT : THIRD PARTY EQUIPMENT IS COVERED THROUGH THE LIMITED WARRANTY DESIGNATED BY THE ORIGINAL EQUIPMENT MANUFACTURER (OEM). WARRANTY COVERAGE AND/OR PARTS & LABOR MAY BE LIMITED TO THE EXTENT OF STATED LIMITED WARRANTY. SUBJECT TO ATLAS METAL DISCRETION.

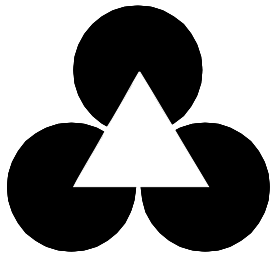

Atlas Metal
INDUSTRIES, INC.

WARRANTY INFORMATION

In order to have your invoice approved for payment by the factory, please note the following:

An authorization number must be obtained from the factory prior to performing any warranty service.

Atlas Metal will not approve excessive labor due to poor access to the unit being serviced. If design does not allow reasonable access, contact the factory.

All travel time that exceeds 100 miles round trip must be authorized by the factory.

**Thank You:
Warranty service Dept.**