

## PDG103MN ECONOMICAL DÖNER KEBAB MACHINE WITH TOP MOTOR GAS

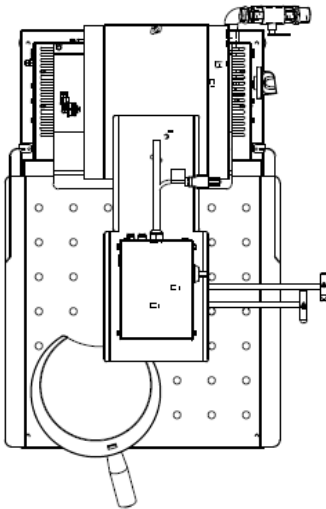

Dimensions in inches

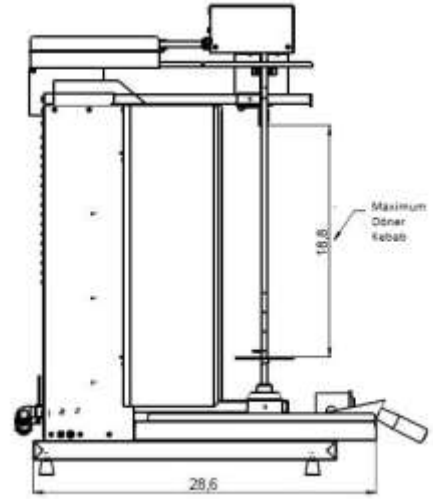
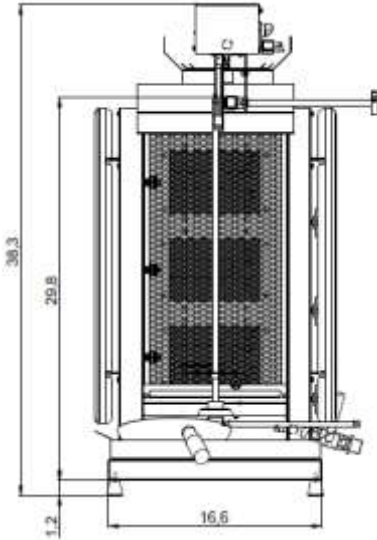

## GENERAL FEATURES

- \* Option of rotating the skewer to the left or right,
- \* The knob will operate with full flame in position 1 and half flame in position 2.
- \* All outer surfaces except the ones in contact with meat made of AISI 430 SB steel.
- \* Rotary skewers capable of operating in inclined position.
- \* Equipped with 3 pcs of 3kw radiants.
- \* Capable of operating under different gas pressures.
- \* Shovel included in the equipment.

## TECHNICAL SPECIFICATIONS

Total Gas Power	30709	Btu/hr
Gas Inlet	1/2"	NPT
Gas Pressure	15	mbar
Tray Area	16x19,5x1,5	inches
Capacity of Döner Kebab Machine	99 - 132	lbs
Power Inlet	115 - 60 AC 1NPE	V - Hz.
Max. Electric Power	17	W
Net Weight	75	lbs
Skewer Length	24,1	inches