



DIM-500A / 700A

ICE MAKER



—DIM-500A / 700A—



—AC-500/700 (Main Unit)—



—D-350/550 (Ice Storage Bin)—

Technical Specifications

Rated Voltage	DIM-500A : 115V / 60Hz DIM-700A : 230V / 60Hz
Ambient Temperature Range	35°F - 110°F
Water Temperature Range	38°F - 90°F
Potable Water Pressure	138kPa-550kPa
Refrigerant	R410A
Fuse Rating	15A / 20A



M: Cube
Weight: 11g
Water content: 2%
Size: 7/8" x 7/8" x 7/8"

Features & Benefits

- Flow-type vertical evaporator with an evaporation temperature of 0°F and an ice core temperature of 8°F.
- It remains fully operational at peak ambient air temperatures up to 110°F.
- Incorporates R290 / R410A refrigerant, which offers higher efficiency and is more environmentally friendly with a lower global warming potential.
- Equipped with an intelligent controller for automatic ice making and ice release. Features a uniquely designed evaporator for more efficient cleaning and includes a fault alarm system.
- All plastic interior plus 100% antimicrobial plastic liner.
- For cleaning, pour the cleaning solution into the water trough. The cleaning process requires approximately 35 minutes to complete.
- Designed for easy repair and maintenance, featuring removable air filter, water trough, and distribution tube for quick and efficient cleaning.
- Ideal for hotels, restaurants, coffee shops, convenience stores, beverage shops, and more—providing rapid cooling for drinks.



Los Angeles | San Francisco | Dallas | Houston |
Florida | Chicago | New Jersey | Colorado | Georgia

 1-800-931-8628

 info@dukersusa.com

www.DukersUSA.com

ICE MAKER

–DIM-500A / 700A–

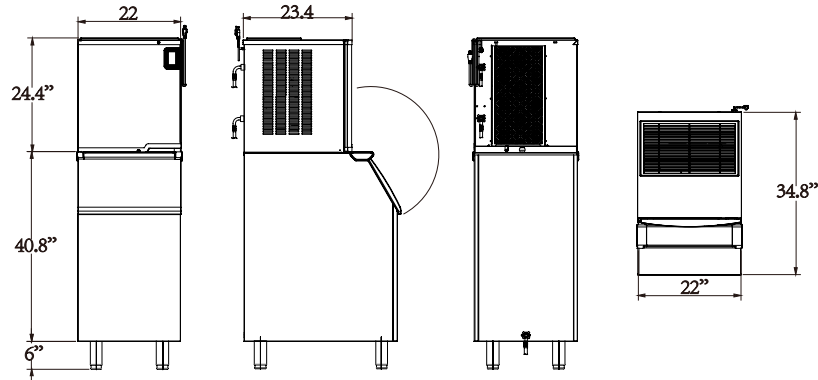

–DIM-500A–

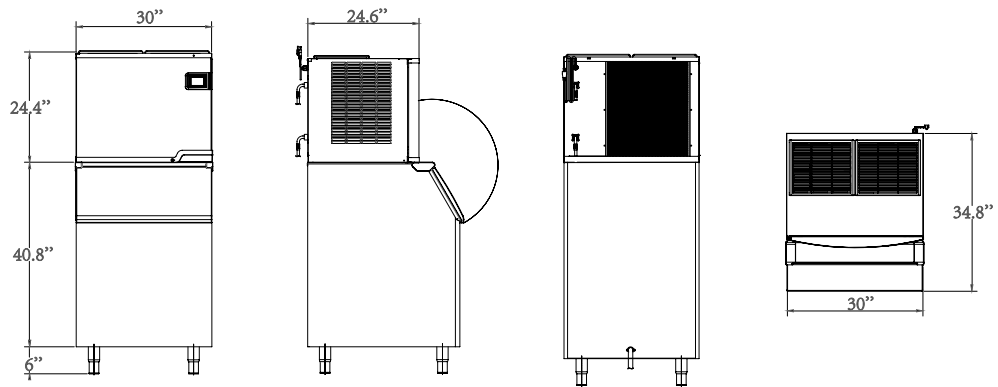

–DIM-700A–

Model	External Dimensions (inches)			Ice Type	Ice Production 24 Hours (Air/Water)		Power Usage (Kwh/100lbs)	Potable Water (Usage/100lbs)	Net Weight (lbs)	Gross Weight (lbs)	Rated Power	Rated Current	BTU Per Hour	NEMA Config.	Bin Storage (lbs)
	W	D	H		70 air / 50 water	90 air / 70 water									
DIM-500A	22	34.8	71.2	Cube	496 lbs	400 lbs	4.9	53L	121.7	140.2	Air-cooled 800W	Air-cooled 3.7A	3500(Average)	5-15P	352
DIM-700A	30				785 lbs	719 lbs	4.8	53L	164.9	176.4	Air-cooled 1000W	Air-cooled 4.5A	4500(Average) 5800(Peak)	6-20P	550

Model	Model	Packing Dimensions (inches)			Gross Weight (lbs)
		W	D	H	
DIM-500A	AC-500 (Main Unit)	24.8	27.17	30.31	63.6
	D-350 (Ice Storage Bin)	25.2	36.61	46.46	46.2
DIM-700A	AC-700 (Main Unit)	32.68	27.95	31.5	80
	D-550 (Ice Storage Bin)	32.28	37.4	47.64	55.8



NEMA-5-15P



NEMA-6-20P



Los Angeles | San Francisco | Dallas | Houston |
Florida | Chicago | New Jersey | Colorado | Georgia



1-800-931-8628



info@dukersusa.com

www.DukersUSA.com