

MADE IN ITALY



## AR800

### Standard Features

- Ideal for working doughs for pizza shops, bakeries and restaurants.
- Stainless-steel Construction
- Variable Speed 10-levels
- Portions 30g (1.1oz) to 800g (28.2oz)
- Works with Max 80% Hydration

The Max capacity and results may vary depending on the ingredients.

- Processes up to 1200 balls per hour
- Teflon Central Spiral for high hydration
- Removable Central Spiral for Easy Cleaning
- Geared motor with a Chain Drive System
- Stainless-Steel portion-receiving trays are removable for cleaning proposes
- Include casters



Variable Speed



Central Spiral Teflon



Up to 1200 balls / hour

1-year parts and labor warranty (US Only)

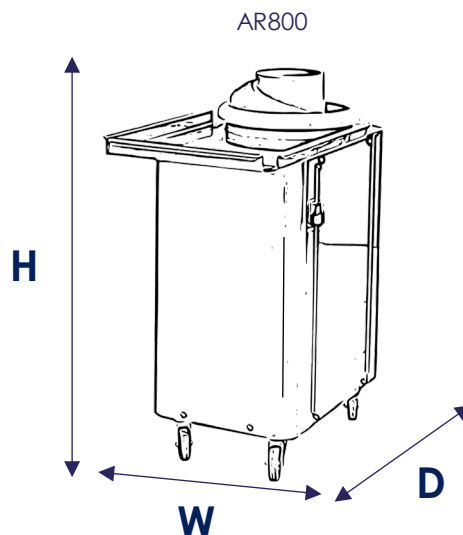
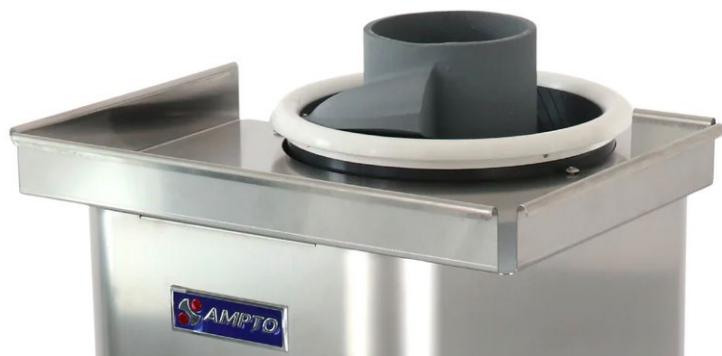

The AR800 is the perfect machine for rounding portions of dough quickly and efficiently, without altering its characteristics. It features a Teflon-coated auger, making it ideal for high hydration doughs and pastries. Plus, it's easy to use, clean, and maintain.

SPECIFICATIONS	
AR800	
Type	Floor
Speeds	Variable (10-levels)
Ball Portion Range	1.1-28.2oz (30-800g)
Power Supply	110v/60Hz/1ph
Motor Power (kW)	0.37
Amps	3.74
Plug / Connection	Nema 5-15P
External Dim WxDxH	17.2" x 29.1" x 33.0" 43.7 x 73.9 x 83.8 cm
Weight	160 lbs (72.6 kg)
Shipping Dim WxDxH	22.5" x 33.5" x 40.0" 57.2 x 85.1 x 101.6 cm
Shipping Weight	170 lbs (77.1 kg)



Notes:

- Dough Hydration must be between 60% and 80% for best results\*
- For cleaning purposes, wait for the machine to completely dry; then, use a wet cloth and a gentle soap if necessary. Do not use hard detergents.



Nema 5-15 125 VAC  
2 Pole, 3 Wire  
Grounding

\*AMPTO is continuously improving products. Specifications are subject to change without notice.\*