

CSS30-4

STAINLESS STEEL EXHAUST HOOD
N.S.F. LISTED. CONFORMS TO NFPA96

Hood Constructed with continuous liquid-tight weld in conformance to IMC 2024 507.2.5.

Hood material: 18 Gauge 430 STAINLESS STEEL (#3 polish) where exposed.

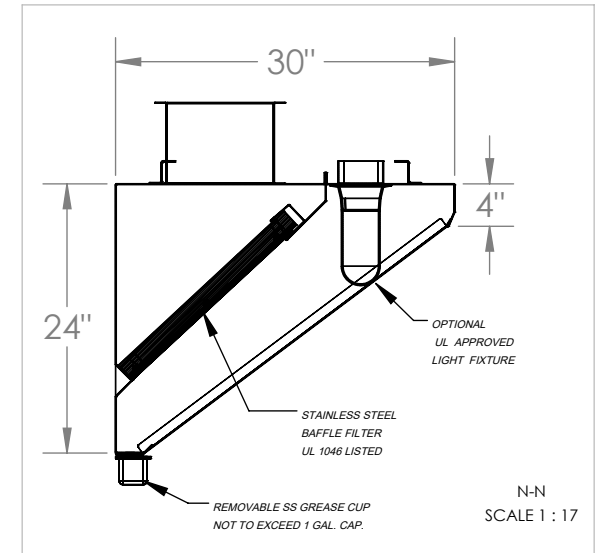

MODEL INFORMATION						
TYPE	DIMENSIONS			CFM SPECS		WEIGHT
	LENGTH	WIDTH	HEIGHT	EXHAUST PLENUM	SUPPLY PLENUM	
I	48"	30"	24"	1000 @ 0.5 ESP	N/A	88 lbs

OBS.: Installing contractor have the responsibility to ensure hood clearance from limited-combustible and combustible materials is compliant with local code requirements.

STANDARD COMPONENTS					
MOUNTING BRACKET 12-GAUGE GALVANIZED	Grease Drain	Grease Cup Stainless Steel NSF	Grease Filter Stainless Steel UL 1046		
QTY	QTY	QTY	QTY	Length	Height
4	1	1	0	16"	20"
			1	20"	20"
			1	25"	20"

SUGGESTED COMPONENTS							
Exhaust Collar		Supply Collar		Light Fixture		Shipping Crate Dimensions (in) and Weight (lb)	
16-Gauge Cold Rolled Build		N/A		UL Listed (Included Component)		Length:	52"
QTY	Size	QTY	SIZE	QTY	Height:	Width:	34"
1	9.5" x 9.5"	N/A	N/A	1	Weight:	Height:	32"
							128 lbs

IMPORTANT:

- 1- Drawing presented shows a typical overview of a Hood system installation, and is not intended to be used for permitting purposes.
- 2- It is the responsibility of the installing contractor to assure that the hood, grease duct and fire suppression system are installed in compliance with NFPA17A, NFPA70, NFPA72, NFPA 96, IMC, state and local codes.
- 3- The hood drawing presented on this document may vary based on which optional components were installed upon the client's request.
- 4- It is the responsibility of the installing contractor to observe field dimensions required based on hood spec, ductwork and options installed.

 PO BOX 47607 - ATLANTA, GA 30360 PHONE: 770.936.0770 - www.superiorhoods.com	PROJECT		CSS30-4		
	TITLE		MODEL CSS30 STANDARD SUBMITTAL SHEET		
APPROVED	CODE		DWG NO		REV
CHECKED					01
DRAWN	PRODUCTION	2025	SCALE: 1:34	WEIGHT: 88 lbs	SHEET: 1/2

PROFILE VIEW

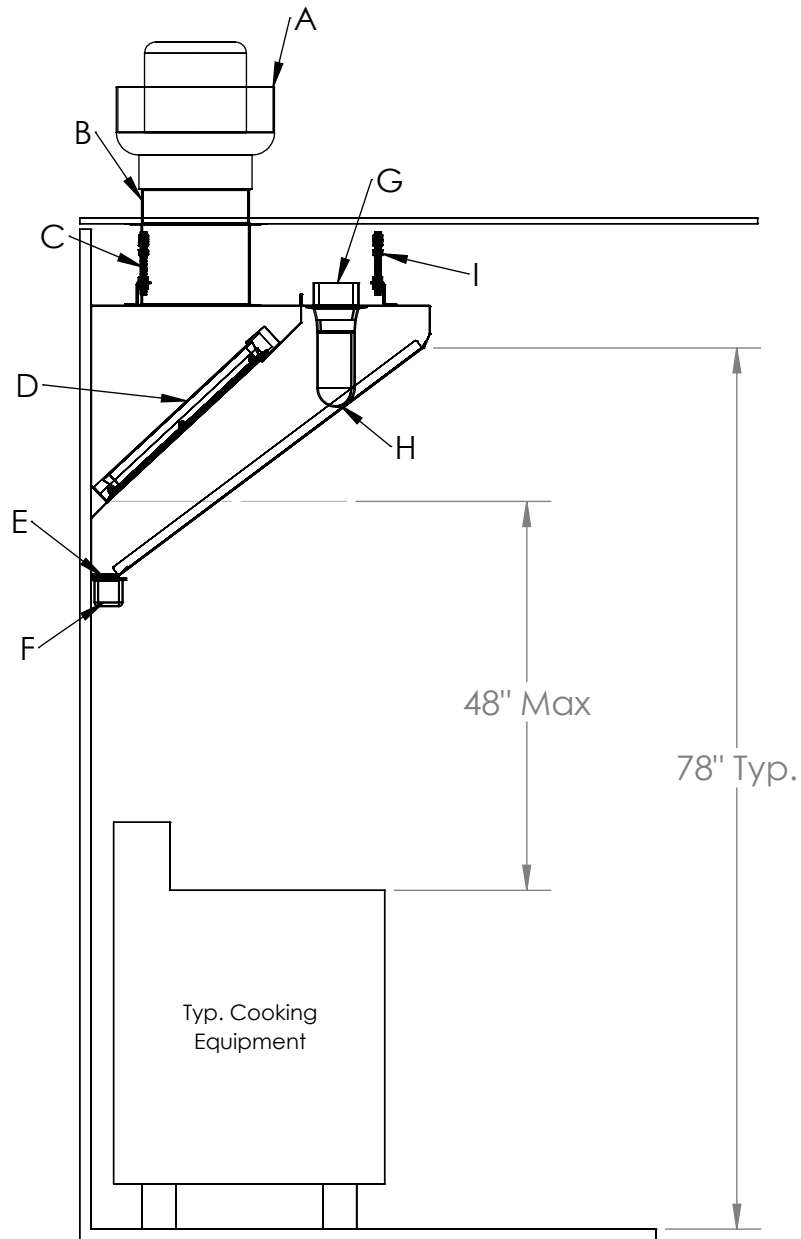

ITEM	DESCRIPTION
A	Exhaust Fan
B	Exhaust Curb 3" Tall Typ.
C	Exhaust Riser (Sold Separately)
D	UL 1046 Approved Stainless Steel Grease Filter
E	Grease Drain Channel
F	Removable Grease Cup not to exceed 1 Gal. Cap
G	Electrical Box (Sold Separately)
H	UL Approved Light Fixture (Sold Separately)
I	Mounting Bracket Assembly

Mounting Bracket Assembly Recommended:

- Threaded Rod not smaller than 3/8"

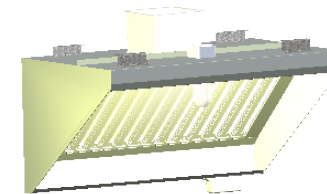
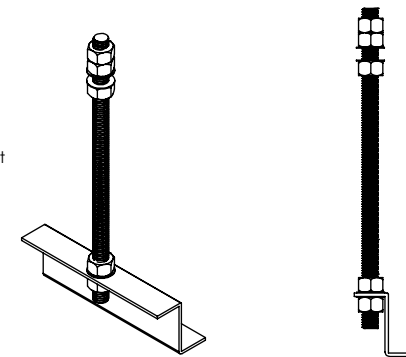

 PO BOX 47607 - ATLANTA, GA 30360 PHONE: 770.936.0770 - www.superiorhoods.com	PROJECT			CSS30-4
	TITLE			
APPROVED	CODE		DWG NO	REV
CHECKED				01
DRAWN	PRODUCTION	2025	SCALE: 1:17	SHEET: 2/2