

BSSM48-9 ETL

STAINLESS STEEL EXHAUST HOOD N.S.F. LISTED. CONFORMS TO NFPA96

Hood Constructed with continuous liquid-tight weld in conformance to IMC 2024 507.2.5.

Hood material: 18 Gauge 430 STAINLESS STEEL (#3 polish) where exposed.

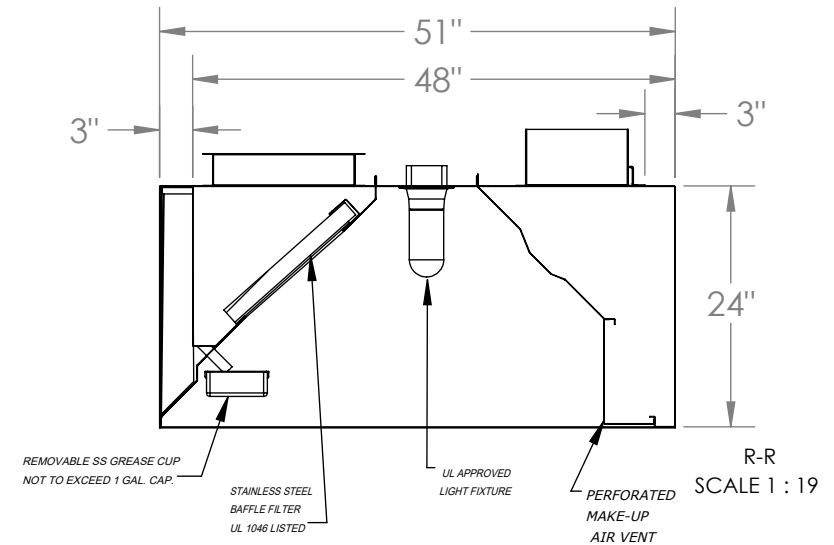

MODEL INFORMATION							
TYPE	DIMENSIONS			CFM SPECS		WEIGHT	
	LENGTH	WIDTH	HEIGHT	EXHAUST PLENUM	SUPPLY PLENUM		
1	108"	51"	24"	2700 @ 0.5 ESP	2160 @ 0.12 ESP	325 lbs	

OBS.:
Installing contractor have the responsibility to ensure hood clearance from limited-combustible and combustible materials is compliant with local code requirements.

STANDARD COMPONENTS INCLUDED							
MOUNTING BRACKET 12-GAUGE GALVANIZED	Light Fixture	Standoff	Grease Drain	Grease Cup Stainless Steel NSF	Grease Filter Stainless Steel UL 1046		
QTY	UL Listed (Included Component)	3" back standoff included	QTY	QTY	QTY	Length	Height
4	QTY		1	1	0	16"	16"
	2				4	20"	16"
					1	25"	16"

COMPONENTS							
Exhaust Collar		Supply Collar (Built-in Fire Damper) ¹		Side Standoff	Shipping Crate Dimensions (in) and Weight (lb)		
16-Gauge Cold Rolled Build		16-Gauge Cold Rolled Build			<input type="checkbox"/> NONE <input type="checkbox"/> 3" <input type="checkbox"/> _____	Length:	112"
QTY	Size	QTY	Size	Width:		55"	
1	14"x 18"	2	10"x16"	Height:		32"	
				Weight:		415 lbs	

¹ BUILT-IN MAKE UP AIR PLENUM HOODS are REQUIRED to have fire dampers, according to the NFPA 96.

IMPORTANT:

- Drawing presented shows a typical overview of a Hood system installation, and is not intended to be used for permitting purposes.
- It is the responsibility of the installing contractor to assure that the hood, grease duct and fire suppression system are installed in compliance with NFPA17A, NFPA70, NFPA72, NFPA 96, IMC, state and local codes.
- The hood drawing presented on this document may vary based on which optional components were installed upon the client's request.
- It is the responsibility of the installing contractor to observe field dimensions required based on hood spec, ductwork and options installed.
- BUILT-IN MAKE UP AIR PLENUM HOODS are REQUIRED to have fire dampers, according to the NFPA 96.

 PO BOX 47607 - ATLANTA, GA 30360 PHONE: 770.936.0770 - www.superiorhoods.com			PROJECT			BSSM48-9 ETL			
			TITLE			MODEL BSSM48 ETL STANDARD SUBMITTAL SHEET			
APPROVED			CODE			DWG NO			REV 01
CHECKED			DRAWN			PRODUCTION			
2025			SCALE: 1:34			WEIGHT: 325 lbs			SHEET: 1/2

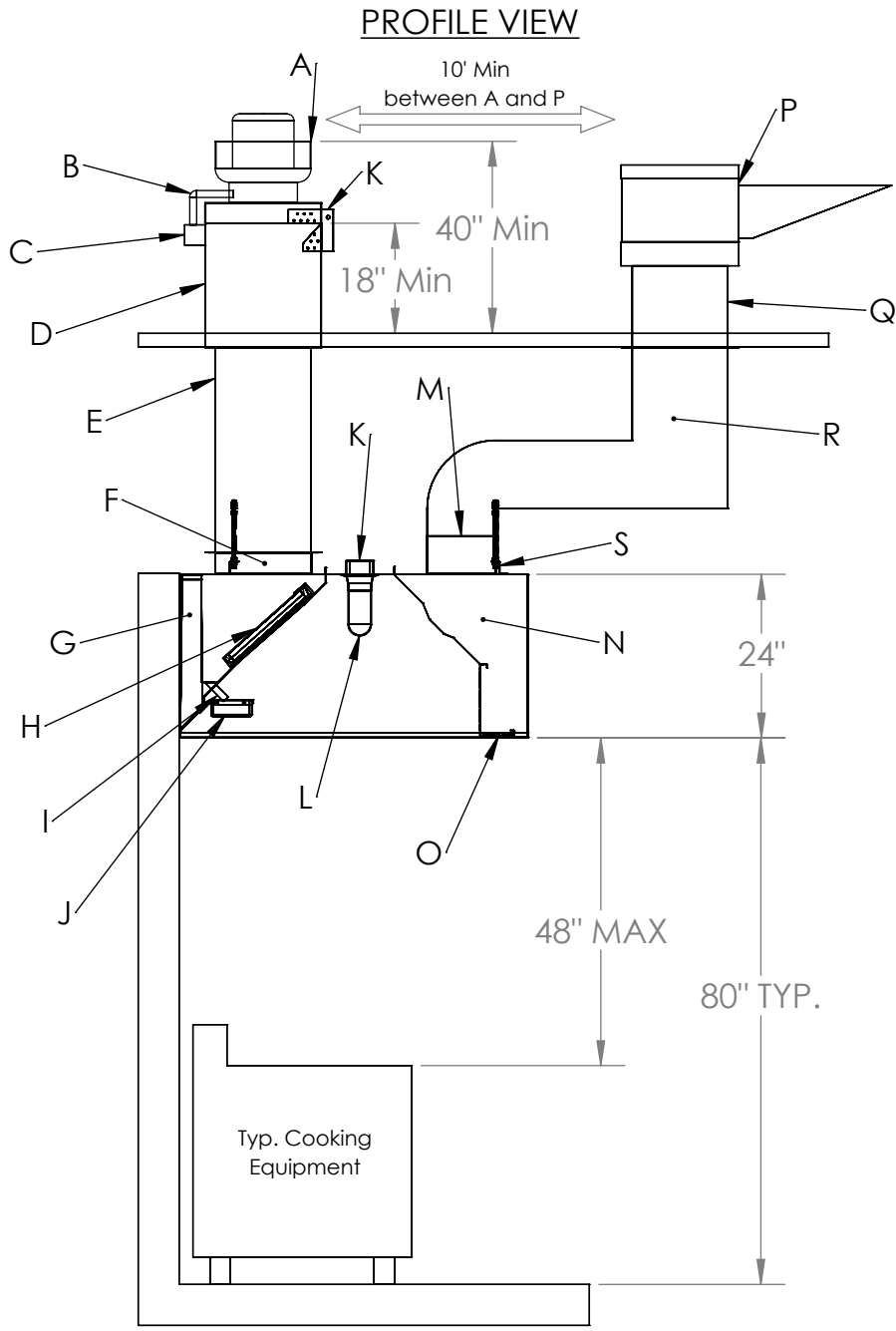

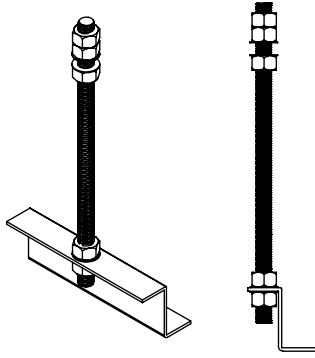

Mounting Bracket Assembly Recommended:

- Threaded Rod not smaller than 3/8"

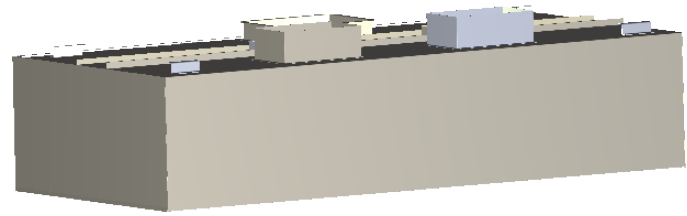

ITEM	DESCRIPTION
A	Exhaust Fan
B	Grease Trap Box drain pipe
C	Grease Trap Box
D	Exhaust Curb 22" Tall Typ.
E	16-Gauge cold rolled steel grease duct liquid-tight welded
F	Exhaust Riser
G	Built-in 3" Standoff
H	UL 1046 Approved Stainless Steel Grease Filter
I	Stainless Steel 1" Grease Drain Pipe
L	UL Approved Light Fixture
J	Removable Grease Cup not to exceed 1 Gal. Cap
K	Electrical Box
M	16"x10" Fire Dumper
N	Integrated Supply Air Plenum
O	Perforated Aluminum Supply Air Difuser (3003, H14)
Q	Make Up Air Curb 12" Tall Typ
R	Galvanized Make-Up Air Drop
P	Make Up Air Fan
S	Mounting Bracket Assembly



 PO BOX 47607 - ATLANTA, GA 30360 PHONE: 770.936.0770 - www.superiorhoods.com	PROJECT BSSM48-9 ETL		
	TITLE TYPICAL HOOD SYSTEM INSTALLATION		
APPROVED	CODE	DWG NO	REV 01
CHECKED			
DRAWN	PRODUCTION	2025	SCALE: 1:28
			SHEET: 2/2