

VSSD48-7

STAINLESS STEEL EXHAUST HOOD N.S.F. LISTED. CONFORMS TO NFPA96

Hood Constructed with continuous liquid-tight weld in conformance to IMC 2024 507.2.5.

Hood material: 18 Gauge 430 STAINLESS STEEL (#3 polish) where exposed.

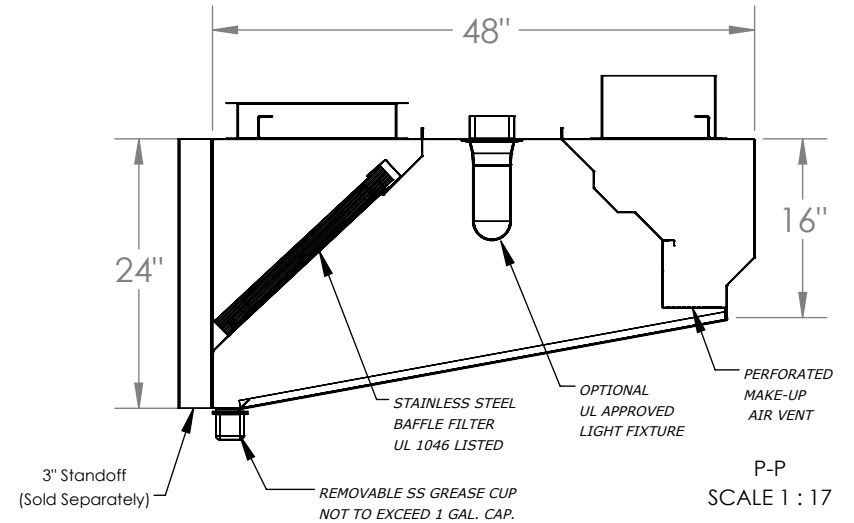

MODEL INFORMATION						
TYPE	DIMENSIONS			CFM SPECS		WEIGHT
	LENGTH	WIDTH	HEIGHT	EXHAUST PLENUM	SUPPLY PLENUM	
1	84"	48"	24"	2100 @ 0.5 ESP	1680 @ 0.12 ESP	214 lbs

OBS.: Installing contractor have the responsibility to ensure hood clearance from limited-combustible and combustible materials is compliant with local code requirements.

STANDARD COMPONENTS					
MOUNTING BRACKET 12-GAUGE GALVANIZED		Grease Drain	Grease Cup Stainless Steel NSF	Grease Filter Stainless Steel UL 1046	
QTY	QTY	QTY	QTY	Length	Height
4	1	1	0	16"	20"
			3	20"	20"
			1	25"	20"

SUGGESTED COMPONENTS							
Exhaust Collar		Supply Collar (Built-in Fire Damper)†		Standoff	Light Fixture	Shipping Crate	
16-Gauge Cold Rolled Build		16-Gauge Cold Rolled Build		<input type="checkbox"/> NONE <input type="checkbox"/> 3"	UL Listed (Included Component)	Dimensions (in) and Weight (lb)	
QTY	Size	QTY	Size		QTY	Length:	88"
1	14" x 14"	1	10" x 16"		1	Width:	52"
						Height:	32"
						Weight:	284 lbs

†BUILT-IN MAKE UP AIR PLENUM HOODS are REQUIRED to have fire dampers, according to the NFPA 96.

IMPORTANT:

- 1- Drawing presented shows a typical overview of a Hood system installation, and is not intended to be used for permitting purposes.
- 2- It is the responsibility of the installing contractor to assure that the hood, grease duct and fire suppression system are installed in compliance with NFPA17A, NFPA70, NFPA72, NFPA 96, IMC, state and local codes.
- 3- The hood drawing presented on this document may vary based on which optional components were installed upon the client's request.
- 4- It is the responsibility of the installing contractor to observe field dimensions required based on hood spec, ductwork and options installed.
- 5- BUILT-IN MAKE UP AIR PLENUM HOODS are REQUIRED to have fire dampers, according to the NFPA 96.

 PO BOX 47607 - ATLANTA, GA 30360 PHONE: 770.936.0770 - www.superiorhoods.com	PROJECT		VSSD48-7	
	TITLE		MODEL VSSD48 STANDARD SUBMITTAL SHEET	
APPROVED	CODE	DWG NO	REV	01
CHECKED				
DRAWN	PRODUCTION	2025	SCALE: 1:34	WEIGHT: 214 lbs SHEET: 1/2

PROFILE VIEW

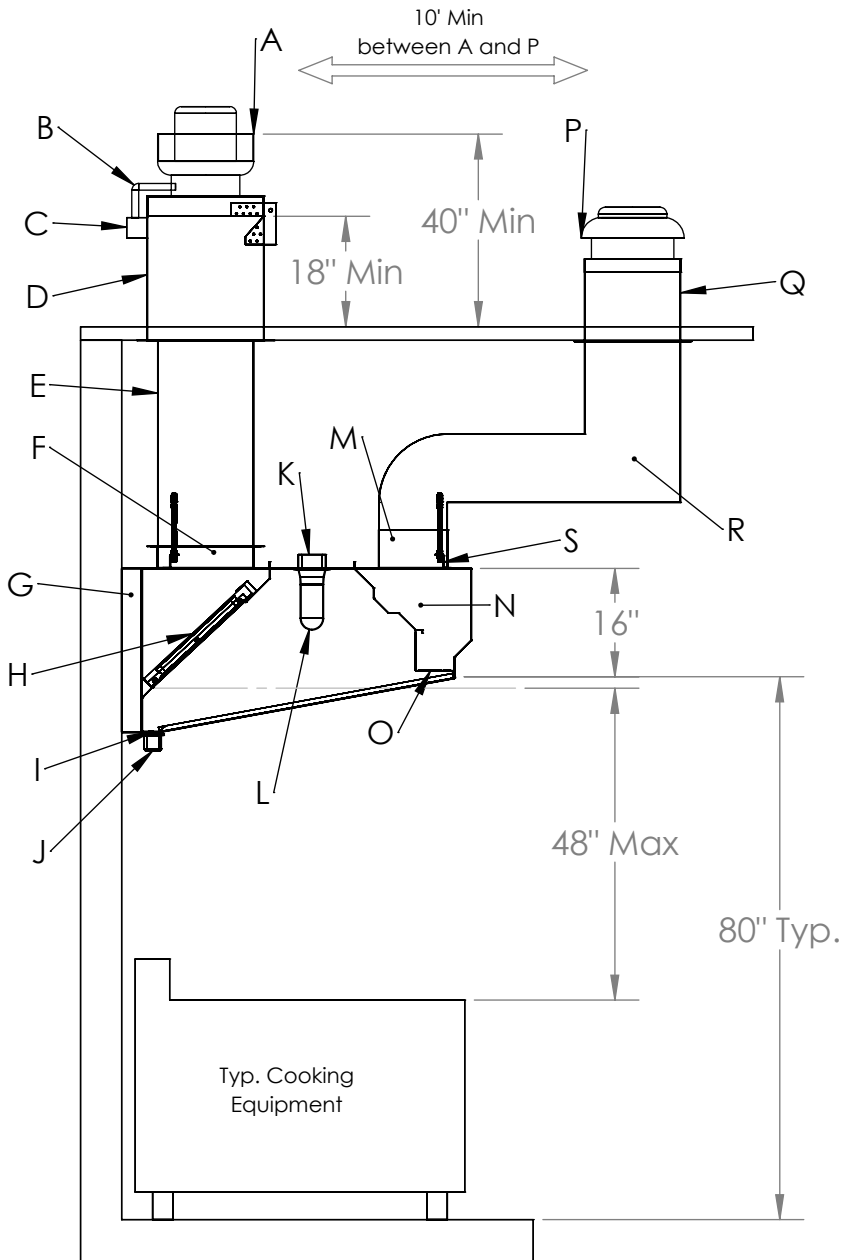

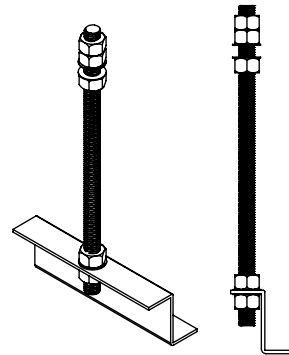

Mounting Bracket Assembly Recommended:

- Threaded Rod not smaller than 3/8"

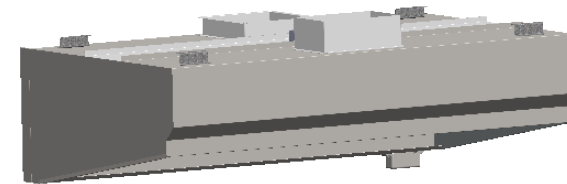

ITEM	DESCRIPTION
A	Exhaust Fan
B	Grease Trap Box drain pipe
C	Grease Trap Box
D	Exhaust Curb 22" Tall Typ.
E	16-Gauge cold rolled steel grease duct liquid-tight welded
F	Exhaust Riser
G	3" Standoff (Sold Separately)
H	UL 1046 Approved Stainless Steel Grease Filter
I	Grease Drain Channel
J	Removable Grease Cup not to exceed 1 Gal. Cap
K	Electrical Box
L	UL Approved Light Fixture
M	16"x10" Fire Dumper
N	Integrated Supply Air Plenum
O	Perforated Aluminum Supply Air Difuser (3003, H14)
P	Make Up Air Fan
Q	Make Up Air Curb 12" Tall Typ
R	Galvanized Make-Up Air Drop
S	Mounting Bracket Assembly



 PO BOX 47607 - ATLANTA, GA 30360 PHONE: 770.936.0770 - www.superiorhoods.com	PROJECT			VSSD48-7
	TITLE			
APPROVED	CODE	DWG NO		REV
CHECKED				01
DRAWN	PRODUCTION	2025	SCALE: 1:28	SHEET: 2/2