



Project: _____

Item: _____

Quantity: _____

Date: _____

Drop-in Models

Drop-in Models	Pans
<input type="checkbox"/> DI-TA454-20-01-T/H	1
<input type="checkbox"/> DI-TA454-20-02-T/H	2
<input type="checkbox"/> DI-TA454-20-03-T/H	3
<input type="checkbox"/> DI-TA454-20-04-T/H	4
<input type="checkbox"/> DI-TA454-20-05-T/H	5

TempestAir™ Drop-In **DI-TA454-20-05-T/H** with turned down edge.



- Holds products in open pans at 40° F or less
- Maintains critical temperatures without freezing
- Self contained design allows for easy installation in any counter, cart or table.

Benefits

LTI's TempestAir™ Cold Food Well Drop-In was developed to hold product in open pans at a temp. of 40 degrees F or less, while in an ambient temp. of up to 86 degrees F.

The patented design features a refrigeration system that utilizes convection air to produce a circulating "cold air zone" around the full area of the insert pan. The system maintains critical temperatures without risk of freezing.

Product must be pre-chilled to a temperature below 40 degrees F, and kept at a level 1/2" below the top of the storage pan to ensure proper cooling.

Our "drop-in" configuration provides a self-contained unit that allows for easy installation in any counter, serving line, cart or table.

Meets NSF7 requirements with pans flush with countertop.

Muffin Fan

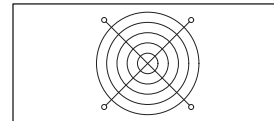

Standard Features

- ✓ Full sealing gasket
- ✓ Pan dividers
- ✓ 6' cord and plug
- ✓ 120V, 60, 1PH
- ✓ Muffin fans (shown at right)

Optional Features (specify)

- Custom sign/logo (specify _____)
- Small pan divider bars
- Hugged edge (H)
- Turned down edge (T)
- Skirt mounted on/off switch pre-wired to electrical receptacle
- Other voltage, phase, cycle (specify _____)

REV 6/16/25



LTI, Inc.
1947 Bill Casey Parkway (888) 584-2722
Jonesboro, GA 30236 lowtempind.com

Approvals: _____

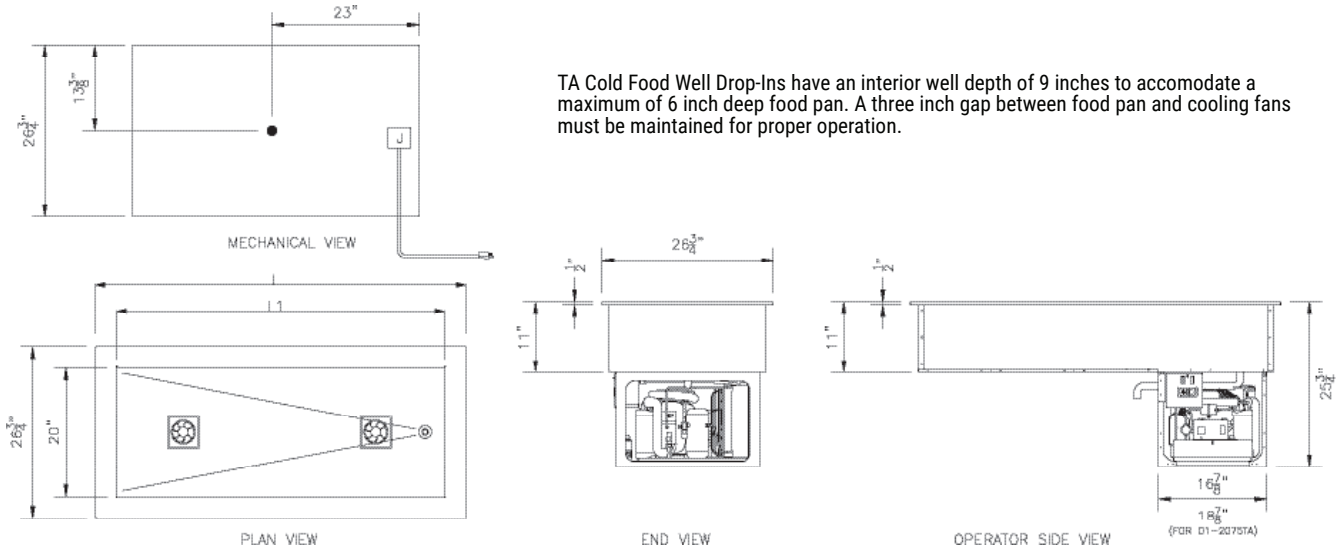

Model #	Pans	L	L1	Cut Out Size	H.P.	Volts	Fans	Amps (120V)	NEMA Plug
DI-TA454-20-01-T/H	1	19-1/2"	12"	17-7/8" x 25-1/8"	1/3	120	1	5.2	5-15P
DI-TA454-20-02-T/H	2	32-1/4"	24-3/4"	29-7/8" x 25-1/8"	1/3	120	1	5.2	5-15P
DI-TA454-20-03-T/H	3	45"	37-7/8"	42-7/8" x 25-1/8"	1/3	120	1	5.2	5-15P
DI-TA454-20-04-T/H	4	57-3/4"	51"	55-7/8" x 25-1/8"	1/3	120	2	5.2	5-15P
DI-TA454-20-05-T/H	5	70-1/2"	64"	68-7/8" x 25-1/8"	1/3	120	2	5.2	5-15P

Specifications

Top perimeter frame to be constructed of 14 gauge stainless steel, welded, ground and polished with a thermal break provided between the top and refrigerated interior. Interior pan to be 18 gauge stainless steel, fully welded, ground and polished with a 3/4" open drain. To be fully insulated with a 1-1/2" to 2" urethane insulation. The exterior jacket to be constructed of heavy gauge galvanized steel.

Refrigeration system to be hermetically sealed compressor operating on R454C refrigerant and will include the TempestAir circulating cold air system. Thermostatic control will clear the cooling surface of frost on every cycle.

All switches and controls to be fully accessible. Provide with cord and plug.

Units to be UL listed and shall bear the UL classified EPH label for sanitation meeting all NSF7 requirements.

Adequate ventilation must be provided to ensure proper operations of this unit. A minimum louvered opening of 14" x 14" with thru air flow is recommended. A minimum of 205 CFM air flow across the condensing unit area is recommended. Failure to provide adequate ventilation will void manufacturer's warranty. Customer side access is required for service of unit.

Approval/Submittal (signature required)

Adherence to LTI installation instructions is required. Failure to do so may void the warranty.

Signature _____

Date _____

We reserve the right to change specifications and product design without notice. Such revisions do not entitle the buyer to corresponding changes, improvements, additions or replacement for previously purchased equipment.

All equipment to be built in accordance with the Underwriters Laboratories, Inc. and the National Sanitation Foundation, Inc. standards and shall bear the Underwriters Laboratories, Inc. listing label for safety and the Underwriters Laboratories classification label for sanitation.

Patent 5,388,429