

INSTALLATION · OPERATION · MAINTENANCE · PARTS



Spiral Dough Mixer

Sales Department

Toll Free (USA & Canada only):

1.800.683.0928

Phone: 1.210.734.5124

Fax: 1.210.737.3925

Email: sales@bescomfg.com

Service Department

Phone: 1.210.547.4121

Email: service@bescomfg.com

Parts Department

Phone: 1.210.547.4135

Email: parts@bescomfg.com

Connect with us!

#BESCOMFG



www.bescomfg.com

200 Lombardo St. San Antonio, Texas 78207 USA



OWNER'S MANUAL

(Spiral Mixer)



CONTENTS

Introduction.....(2)

Installation & Commissioning.....(3)

Operation.....(4)

Caution.....(8)

Cleaning & Maintenance.....(9)

Trouble Shooting.....(10)

Parts List.....(12)

Wiring Diagram.....(20)

Introduction

Spiral Mixer with a two-timer control panel and a single motor that drives both the hook and the bowl. The hook and bowl are made of stainless steel for long life and ease of cleaning. The full bowl cover keeps flour dust down and protects the operator from the hook while operating.

Owners and operators should carefully read and familiarize themselves with this entire manual before attempting to operate or service this machine. Complying with this manual will ensure years of safe and trouble-free operation.

All of the information, illustrations and specifications contained in this manual are based on the latest product information available at the time of printing. BE&SCO Manufacturing reserves the right to make changes at any time without notice. If questions arise during the operation or servicing, please contact us before proceeding.

Specifications

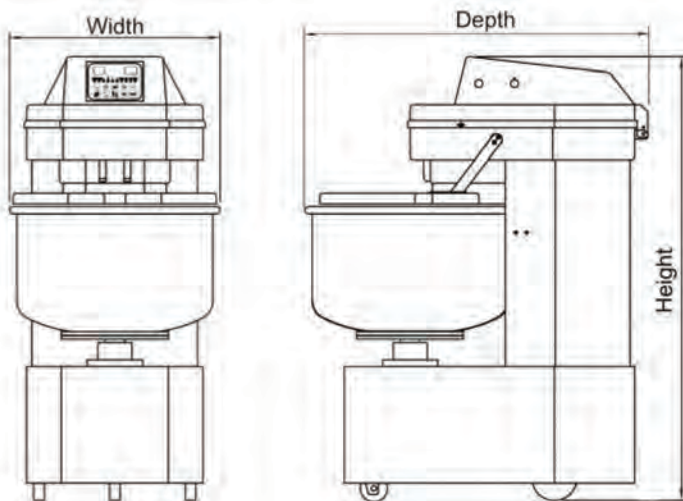

Spec Sheet Attached

Installation

The machine is ready for installation. After uncrating your spiral mixer, inspect the machine for any damage that might have occurred during shipment. Report any damage to us before proceeding. Never attempt to operate this mixer with damaged parts.

- 1). Position the mixer in its appropriate working position, the mixer must be installed on a horizontal and solid floor.
- 2). Adjust the mixer feet to ensure that the mixer is level, and seat it firmly on all four corners. Ensure that no wheels touch the ground. The axles are not designed to support the unit while mixing.
- 3). Connect the correct power supply to the machine as indicated on the machine nameplate.

Commissioning

- 1). Start the mixer to check the direction of rotation of the kneading spiral and the bowl. When viewed from above, both kneading spiral and bowl should rotate clockwise. The arrow on the bowl indicates the correct direction of the bowl. If the rotation direction is incorrect, swap two phases in the plug (white and black wires) to reverse the rotation direction.
- 2). Test the function of the safety emergency stop button. The machine must stop immediately when you press this button.
- 3). Test the function of the limit switch for the bowl safety guard. When the guard is lifted, the machine must stop immediately.



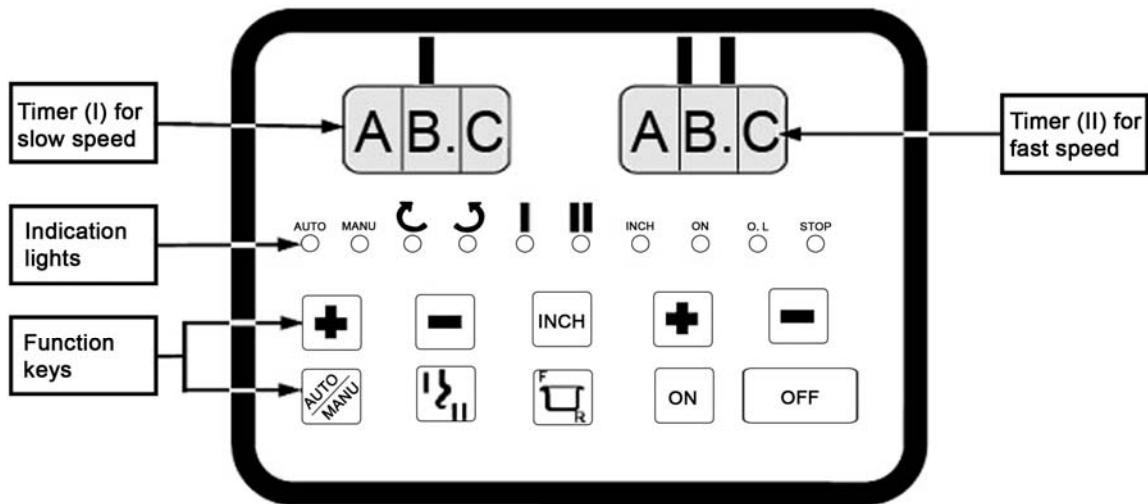

Control Panel



1. Timers

On top of the control panel, there are two timers: Timer I is for slow speed; Timer II is for fast speed. Each timer has three digits.

The unit of A and B are minutes and C is 10 seconds, (for example: 0.1 is 10 seconds, 0.2 is 20 seconds.)

The timers are set by  and  buttons. Press  button to increase the time, the maximum set time is 20 minutes. After 20 minutes, the timer starts from 0 minutes again. Press  button for the opposite operation.

When the spiral mixer is switched ON, timers will show the set time. The timer will only work when mixer is in AUTO mode. The timer will start automatically when the (ON) button is pressed. The slow speed timer will run first and then the fast speed timer second, the mixer stops until timer reaches 0 minute.

When the spiral mixer safety guard is lifted, the timer will stop with the mixer and resume when the guard is lowed down and the ON button is pressed.

When the OFF button is pressed, the timers will return to the set time.

2. Indication lights

Indication lights indicate the running state of the spiral mixer:

A). AUTO/MANUAL lights:

When “AUTO” lamp lights up, spiral mixer is in AUTO operation.

When “MANU” lamp lights up, spiral mixer is in MANUAL operation.

B). Bowl direction lights:

As this Mixer only has one motor, the hook and the bowl will rotate in the same direction.

When  lamp lights up, the bowl and hook are in forward direction.

When  lamp lights up, the bowl and hook are in reverse direction.

C). Mixer speed lights:

As the Mixer only has one motor, when you change the speed of the hook, the speed of the bowl will be also changed.

When  lamp lights up, spiral mixer is in the slow speed state.

When  lamp lights up, spiral mixer is in the fast speed state.

D). Bowl inching light:

When “INCH” lamp lights up, spiral mixer is in manual inch mode.

E). On model light:

When “ON” lamp lights up, spiral mixer is in mixing mode.

F). Light:

When “O.L.” (OVERLOAD) lamp lights up, the overload relay is on. It inform you that the mixer is overload, please switch off the mixer and decrease the mixing weight and restart the machine again.

G). Stop mode light:

When “STOP” lamp lights up, safety cover has been raised during mixing mode.

3. Function keys



AUTO / MANUAL selection



Speed selection button



Bowl direction selection



Inching button



Start button



Stop button

Operation Preparation

Check the mixing bowl is clear of all foreign objects, all control switches are off and operation area should be clear of bystanders.



The electrical cord should be in the appropriate socket and power turned on.

Safety guard should be raised and pushed back fully against stops to avoid injury. The mixer has safety interlocks to prevent mixer operation when the safety guard is lifted.

Weigh out and load ingredients into bowl according to recipe.



Operation Steps

1. Auto operation

A). Press   buttons below  timer to set the desired time for slow mixing speed.





B). Press   buttons below  timer to set the desired time for fast mixing speed.

C). Press  button until the "AUTO" lamp lights up.

D). Press  button until the  lamp lights up.

E). Press  button to start machine.

2. Manual operation

- A). Press  button until the “MANU” lamp lights up.
- B). Press  buttons to select the desired direction.
- C). Press  button to start.
- D). Press  button when you want to stop the operation.

The timer will stop functioning under manual operation.

The mixer will always start with slow speed even if you have selected fast speed to start. When the mixer is running at slow speed, you can press



button to change mixer into fast speed while in manual mode.

3. Control Buttons

When digital panel is damaged, the mixer can be operated by manual switch located at left side of top cover. You can select slow speed or fast speed manually without timer.

- A). Press “ON” to start the machine
- B). “1” means slow speed, “2” means fast speed.

You can stop the machine by pressing the emergency stop button or lifting the safety guard.



CAUTION

1. Use the machine with great care and never be distracted.
2. Do not wear loose fitting clothes or clothing with wide or open sleeves.
3. Do not remove, cover or alter the warning stickers or machine safety covers placed on the machine body.
4. Use machine only for what it was intended.
5. Do not set dough knives or scrapers atop machine, they could fall in during operation and ruin the machine or injure the operator.
6. Do not use the machine with temporary electrical connections or non-insulated cables.
7. Periodically check the state of the power cord and the cable clamp on the machine body, replace it if necessary by an authorized service provider.
8. Discontinue use of the machine if there are broken or missing covers, a damaged cord, or loud or odd noises coming from the machine.
9. Before cleaning or carrying out maintenance, isolate the machine from the power supply first.
10. For all extraordinary maintenance, consult with the manufacturer or authorized personnel.
11. Never insert hands or other objects into the bowl when the machine is in operation. Keep hands and clothing away from bowl rollers while bowl is turning.

CLEANING AND MAINTENANCE

1. Brush off all external surfaces. Use a soft brush and work from the top to the bottom.
2. Remove all old dough using a plastic scraper.
3. Scrape the mixing bowl, the breaker bar, the dough spiral, under the bowl cover inside the mixing bowl, and behind the mixing bowl.
4. Wipe all surfaces with warm water.
5. Apply a detergent/sanitizer and leave on all surface.
6. Scrub to loosen and remove residues.
7. Rinse the bowl and dough spiral mixer tool thoroughly with hot water on a damp rag. **DO NOT POWER WASH OR HOSE OFF MACHINE!**
8. Remove excess moisture with clean towels. Dry all surfaces.

TROUBLE SHOOTING

Fault	Possible Cause	Remedy
The mixer does not operate /start.	Not plugged into the socket at main switch.	Plug in and switch on.
	The main switch is "off".	Turn on.
	The bowl safety guard is open.	Place it down position.
	The mixer overload has been activated.	Contact supervisor / service agent.
	Stop button is still locked in the down position.	Release by rotating and pulling.
The mixer starts and then immediately stops.	Both high and low speed timers are set to zero.	Reset mix cycle on both timers.
	The mixer overload has been activated.	Contact supervisor / service agent.
	Fuse overload at the power board.	Contact supervisor / service agent.
The mixer labors under load.	Dough too stiff / tight.	Review and adjust dough consistency; add more liquid.
	Machine malfunction.	Contact supervisor / Service agent.
The mixer moves or rocks during operation.	Floor not level or the adjustable feet are located incorrectly.	Re-adjust level and stabilize with adjustable foot.
Excessive flour dust coming from mixer.	First speed timer set too short.	Extend first speed mix / blending cycle.
The mixer bowl and dough hook operate in the wrong direction.	Inserting the mixer plug into the incorrect socket after cleaning.	Return to correct position.
	Relocating the mixer in another position after maintenance.	Consult authorized electrical service to rewire plug.

TROUBLE SHOOTING

Fault	Possible Cause	Remedy
The mixer does not stop	Electrical / mechanical malfunction.	Switch off power at main switch. Isolate mixer by removing wall plug. Attach danger tag to machine. Contact service agent.
Bread dough too soft.	Excessive water used in dough (human error). Incorrectly metered / measured through water meter (equipment error). Over-mixed dough	Review recipe and adjust dough consistency. Contact authorized service agent. Review /check /change mix cycle.
Final dough temperature too hot.	Water temperature too hot. Dough mixed too long.	Reduce water temperature. Shorten mix cycle.
Final dough temperature too cold.	Water temperature too cold. Dough mixed too short.	Increase water temperature. Lengthen mix time.
Dough is difficult to remove from the mixing bowl.	Dough left in bowl too long. Dough too soft. Dough over-mixed.	Remove from bowl earlier. Refer-dough too soft. Run food grade oil between dough and bowl at the end of mix cycle to stop dough sticking.

Parts List

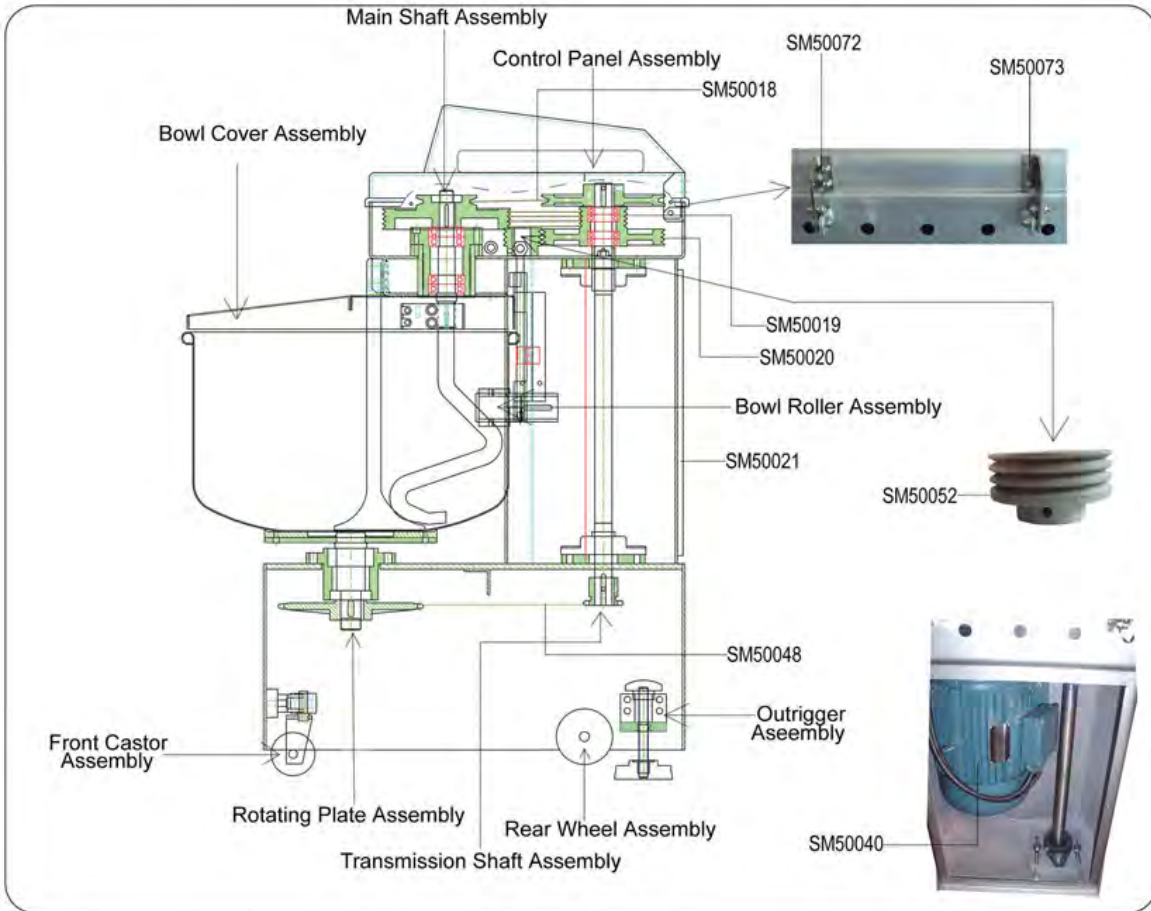

Control Panel Assembly

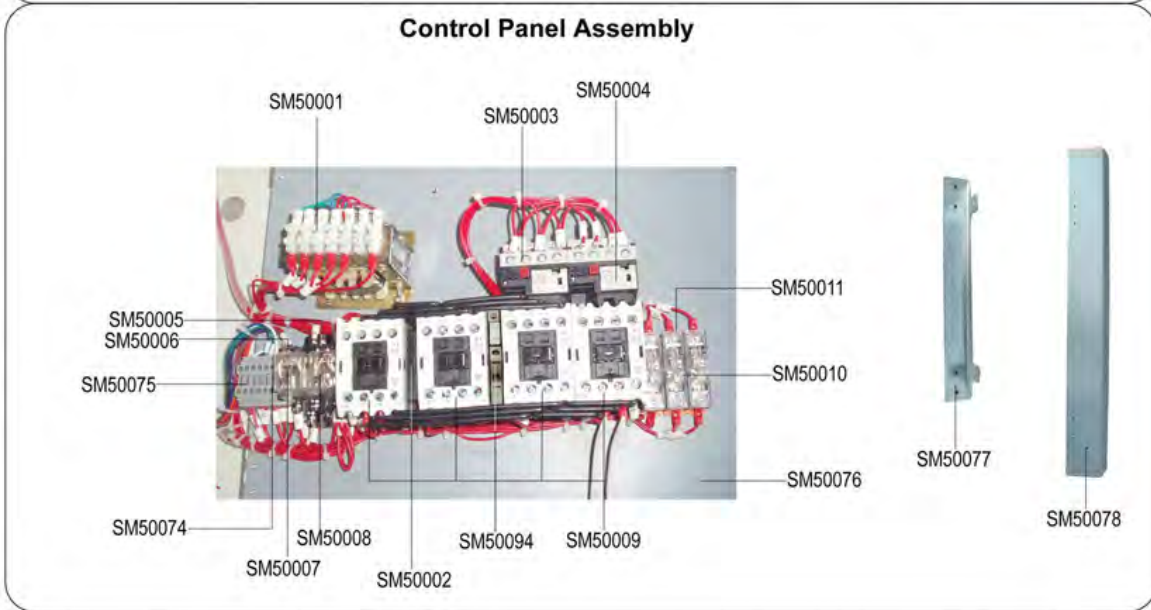

Parts List



Main Shaft Assembly



Parts List

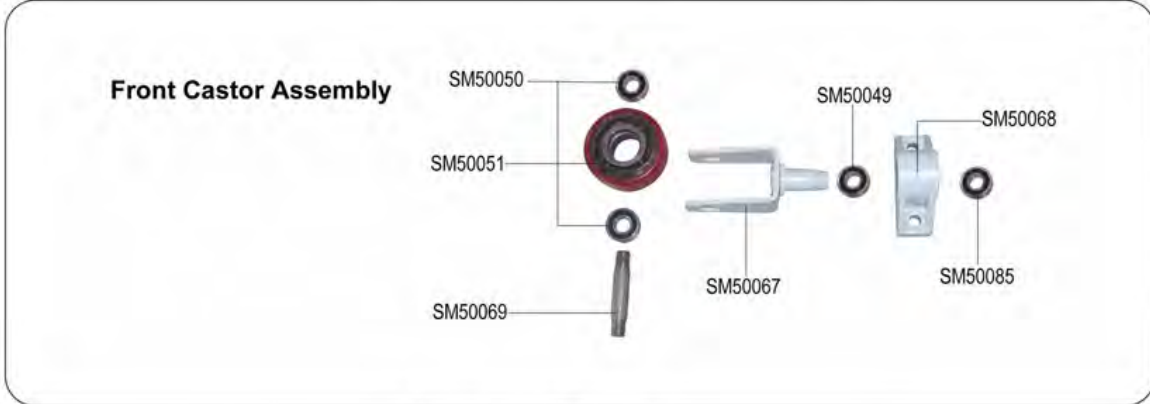
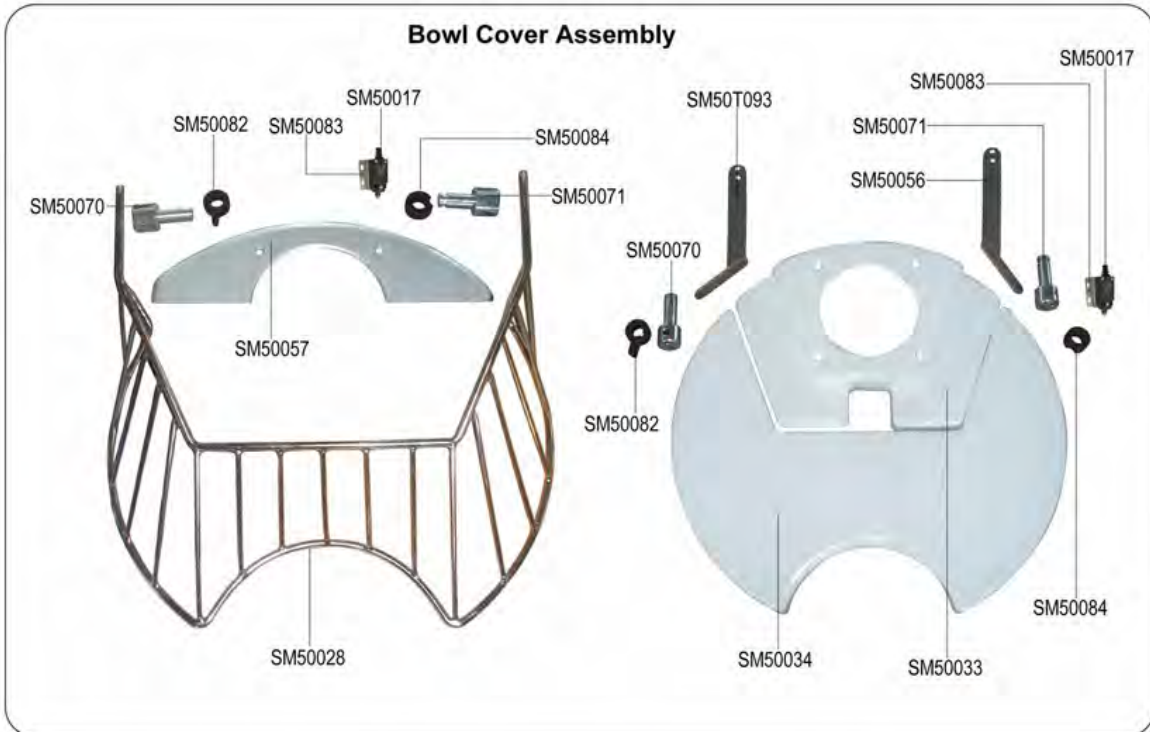

Parts List

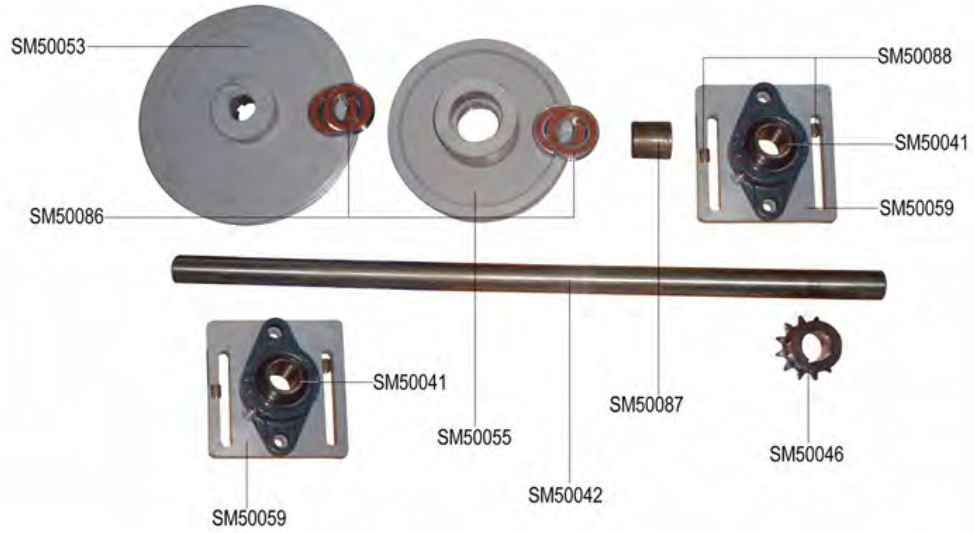

Transmission Shaft Assembly

Bowl Roller Assembly

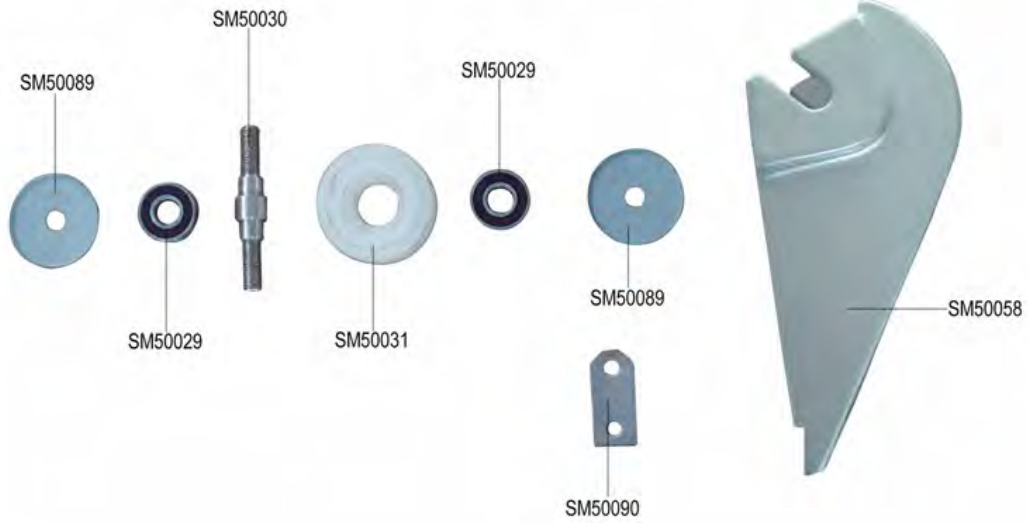

Parts List

Rotating Plate Assembly

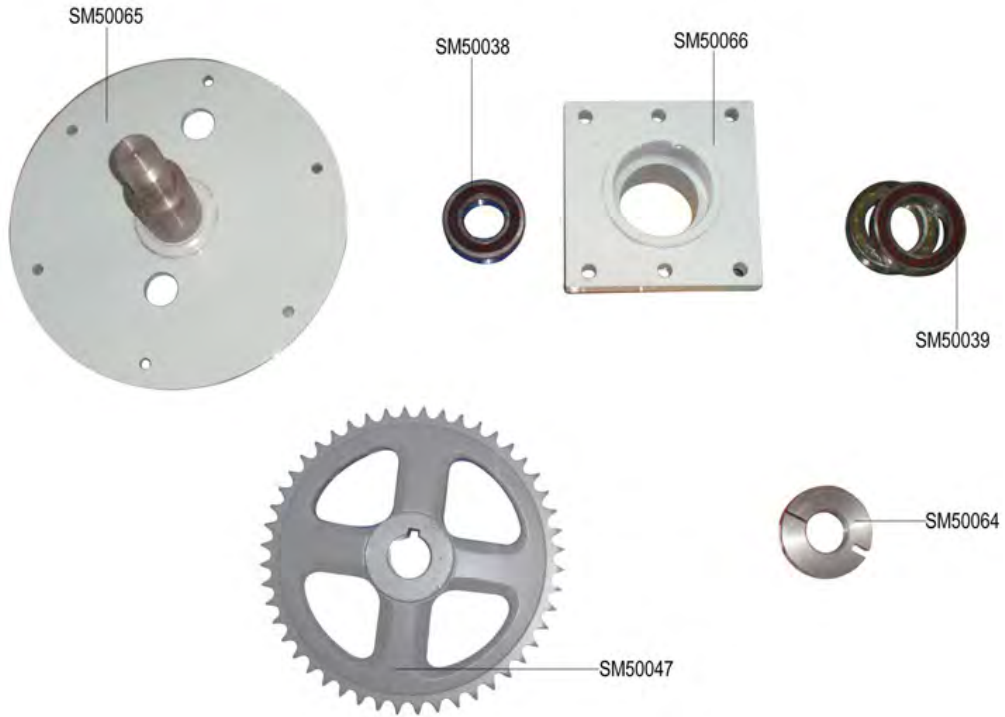

Outrigger Assembly



Parts List

Parts Number	Parts Code	Parts Name	Specification
SM50001	16BYQJBK63-1	Transformer	220V/380V-26V/110V(2A)
	16BYQJBK63-18	Transformer	400V-110V/26V
	16BYQJBK63-16	Transformer	O-208V-220V//110V(13VA)-26V(50VA)
	16BYQJBK63-2	Transformer	415V-80%220V/20%26V
SM50002	16LSLCI-18	Mechanical Connector	
SM50003	16JDQRHN10A-3	Thermal Relay	RHN-10A 5.5-8.5A
SM50004	16JDQRHN10A-4	Thermal Relay	RHN-10A 8.5-12.5A
SM50005	16JDQPYF-08	Relay Seat	
SM50006	16JDQPYF-14	Relay Seat	
SM50007	16JDQMY4-24V	Relay	
SM50008	16JDQMY2-24V	Relay	
SM50009	16JCQCN16-1	Contactors	CU-16 3A1b 24V/50HZ
SM50010	16BXSG111B	Fuse Cover	
SM50011	16BXSZD	Fuse Seat	
SM50012	15ZCL6305VV	Bearing	6305ZZ 2RS
SM50013	15ZCL6206VV	Bearing	62062RS UBC
SM50014	14M371-01	Spacer for Main Shaft	
SM50015	15YFL35*62*7	Oil Seal for Main Shaft	35*62*7
SM50016	14M370-01	Main Shaft	
SM50017	16KGLMEA9112G	Microswitch	
SM50018	15PDLA42	Belt	1PCS
SM50019	15PDL1030	Belt	7M-1030 4PCS
SM50020	15PDL825	Belt	7M-825, 3PCS
SM50021	11M870-01	Machine Rear Cover	1.5T*400*542 SPCC
SM50022	16MBOMX-005	Digital Touch Control Panel	Two-Timer Model
SM50023	16KGLZB5-AD3	Selector Switch	
SM50024	16KGLBE101	Cover for Manual Switch	
	16KGLZA-BD3	Manual Switch	
SM50025	16KGLZA2-BS54	Emergency-Stop Switch	
SM50026	16KGLLOT25ET3	Power Switch	
SM50027	13M444-01-01	Machine Top Cover	
SM50028	11M750-110	Bowl Safety Grid	
SM50029	15ZCL6200VV	Bearing	
SM50030	14M850-01	Bowl Roller Bolt	
SM50031	14M840-01	Bowl Roller	

Parts List

SM50032	11M620-01	Mixing Bowl	
SM50033	13M801-06	Bowl Cover	
SM50034	13M802-06	Bowl Cover	
SM50035	13M640-01	Clamping Block	
SM50036	13M650-10	Center Pillar	
SM50037	14M630-01	Dough Hook	
	14M630-01S	Dough Hook	Stainless Steel
SM50038	15ZCL6207VV	Bearing	62072RS NACHI
SM50039	15ZCL6010VV	Bearing	60102RS NACHI
SM50040	16MDL50-4-02	Motor	B3YD112M-4/8 YD112M-8/4 380V-50HZ-3PH 1.5/3KW
SM50041	15ZCLUCFL206	Bearing (with seat)	UCFL206G FYH
SM50042	14M190-01	Transmission Shaft	
SM50043	15BSLHY01	Outrigger Screw	HY8314.4 B-M16*63
SM50044	14D9016150-01	Foot Pad	
SM50045	15LZL5	Rear Wheel	
SM50046	14M240-01	Sprocket Wheel for Transmission Shaft	
SM50047	14M580-01	Sprocket Wheel for Rotating Plate	
SM50048	15LTL86	Chain	5/8*86
	15LTJ5/8A	Connector for Chain	
	15LTJ5/8B	Connector for Chain	
SM50049	15ZCL51104	Bearing	
SM50050	15ZCL6002VV	Bearing	
SM50051	15LZLH3	Front Castor	
SM50052	14M325-01A	Motor Pulley	FOR 50HZ
SM50053	14M250-01	Transmission Shaft Pulley	
SM50054	14M380-01	Main Shaft Pulley	
SM50055	14M260-01	Bottom Pulley for Transmission Shaft	
SM50056	14M811-10	Bowl Cover Bracket	RIGHT
SM50057	13M770-01	Bowl Cover	
SM50058	13M830-01	Bowl Roller Seat	
SM50059	14M220-01	Bearing Housing for Transmission Shaft	
SM50060	14M142-01	Outrigger Bolt	
SM50061	14M140-06	Support Strut	
SM50062	15ZCL6203VV	Bearing	
SM50063	14M180-01	Shaft for Rear Wheel	

Parts List

SM50064	14M600-01	Lock Nut	
SM50065	14M560-01	Rotating Plate	
SM50066	14M530-01	Bearing Housing	
SM50067	14M160-03	Seat for Front Castor	
SM50068	14M150-03	Bracket for Front Castor	
SM50069	14M170-02	Shaft for Front Castor	
SM50070	14M670-03	Adjusting Wheel Mount Clip	LEFT
SM50071	14M680-03	Adjusting Wheel Mount Clip	RIGHT
SM50072	14M461-01	Fixing Piece for Top Cover	
SM50073	14M471-01	Fixing Piece for Top Cover	
SM50074	16JWB280301	End Plate for Electrical Wire	
SM50075	16DZP280101	Connector	
SM50076	12M491-01	Plate for Control Panel	2t*400*420 SPCC
SM50077	12M492-50	Fixing Piece for Control Panel	2t*64*250
SM50078	12M472-02	Fixing Piece for Control Panel	2T*386*78 SPCC
SM50079	11M880-01	Machine Side Cover	1.2T*142*242 SPCC
SM50080	14M780-05A	Safety Grid Stoper	
SM50081	14M340-01	Bearing Housing for Main Shaft	
SM50082	14M700-02	Adjusting Wheel for Bowl Cover	
SM50083	12M730-04	Bottom Plate for Microswitch	M730-04 SPCC-2t*60*81
SM50084	14M710-02	Adjusting Wheel for Microswitch	
SM50085	15ZCL6202VV	Bearing	
SM50086	15ZCL6006VV	Bearing	
SM50087	14M200-01	Bush for Transmission Shaft	
SM50088	14M230-01	Brass Bolt	
SM50089	14M845-01	Watertight Cover	
SM50090	12M860-02	Fixing Piece	SUS304 2t*25*49
SM50091	14D9016150-03	Bushing	
SM50092	2PDS20	Stainless Steel Gasket	φ20
SM50093	14M810-10	Bowl Cover Bracket	LEFT
SM50094	16MKCNI-18	Interlock	

Parts List

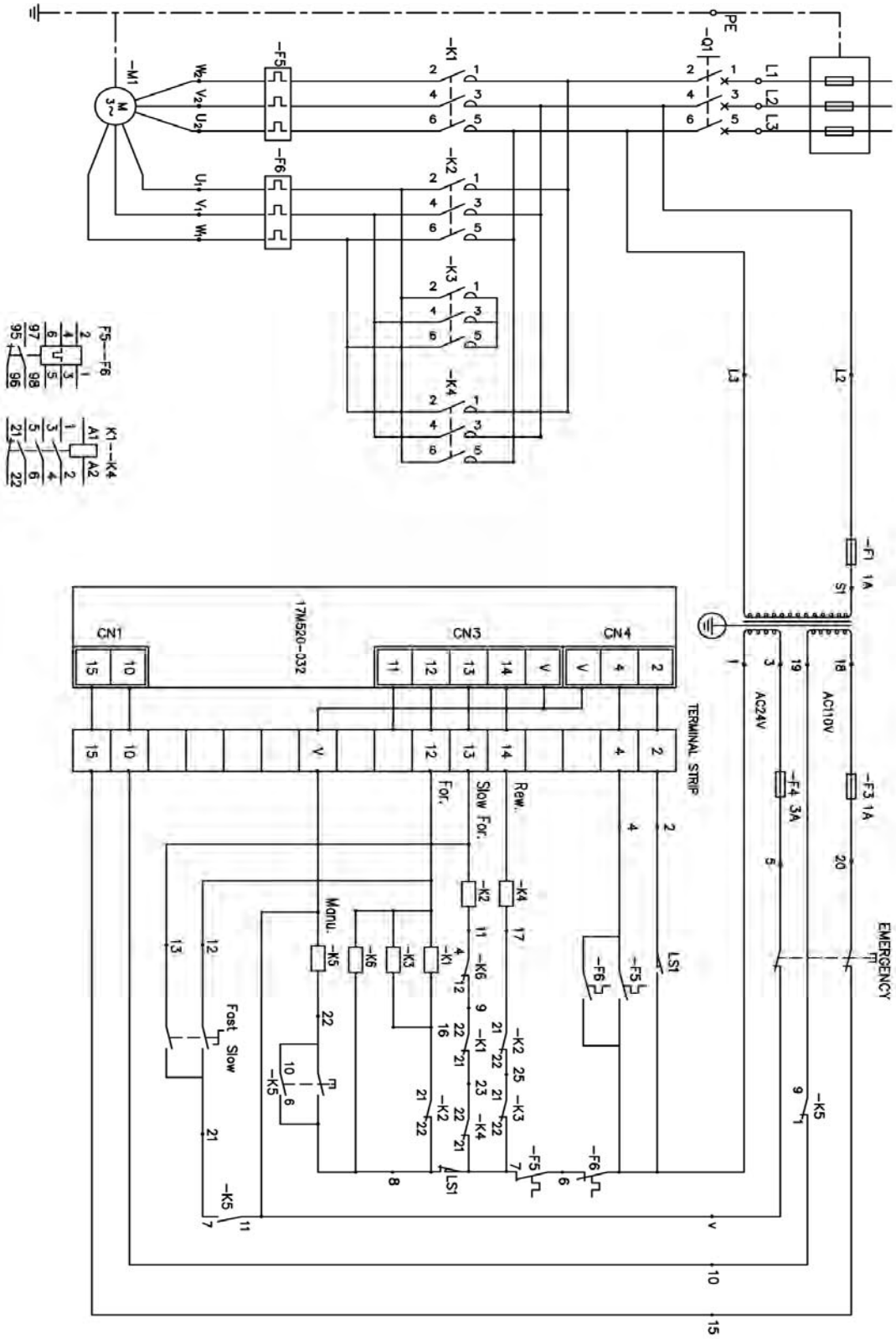

F5--F6		K1--K4	
2	1	A1	A2
4	3	1	2
6	5	3	4
97	8	5	6
98	21	6	22
95			

Original Equipment Warranty

BAKERY EQUIPMENT & SERVICE CO., INC. warrants that its products, as supplied to the original user, is free from defects in material and workmanship, and is suitable for the use for which it is sold. The Company's obligation under this warranty shall be limited to replacing, or at the option of BAKERY EQUIPMENT & SERVICE CO., INC. repairing, without charge any part found to be defective and expense incurred (labor and material) for its installation for a period of ninety (90) days or 750 hours of operation, whichever occurs first, from date of shipment from the factory, or upon special written request to the factory and acknowledged by the factory from the date of installation when there is a long installation delay. After said ninety (90) days or 750 hours of operation and for (1) year or 3,000 hours of operation, whichever comes first from warranty initiation date, this warranty shall apply to defective parts replacement at no charge to original user.

This warranty does not cover any defect due to or resulting from handling, abuse, misuse, improper maintenance and cleaning, or harsh chemical action, nor shall it extend to any unit from which the serial number has been removed or altered, or acts of God. BE&SCO equipment is solely intended for use in a commercial facility. The warranty will not be supported and may be voided if BE&SCO equipment is used in a non-commercial or household setting. Adjustments such as calibrations, leveling, tightening of fasteners or plumbing connections normally associated with original installation are the responsibility of the dealer or installer and not of BAKERY EQUIPMENT & SERVICE CO., INC.

BAKERY EQUIPMENT & SERVICE CO., INC. shall not be liable, directly or indirectly, under any circumstances for consequential or incidental damages, including, but not limited to: (i) any loss of business or profits; and (ii) labor, material or other charges, claims, losses or damages incurred or suffered from, in connection with or in consequences of the working upon, alteration, or repair of any such defective products or parts by persons or firms other than BAKERY EQUIPMENT & SERVICE CO., INC.

This warranty applies only to products shipped to and used with the Continental United States and Canada. All other customers will be provided a spare parts kit in lieu of the above warranty. These kits will be provided with delivery of your purchased equipment. The kit shall consist of parts identified, at the sole discretion of Bakery Equipment & Service Co., INC.

At Bakery Equipment & Service Co., INC., we continuously strive to provide the highest quality products and services. This warranty serves to exhibit our commitment to this endeavor.



Telephone (210) 734-5124 or (800)-683-0928
200 Lombrano Street, San Antonio, Texas 78207 USA

www.bescomfg.com