

# **Gas Rotisserie**

## **Instruction manual**

**This manual contains important information regarding your purchased equipment. Please read the manual thoroughly prior to equipment set-up, operation and maintenance.**

**Failure to comply with regular maintenance guidelines outlined in this manual may void the warranty. Please keep it for future reference after installation and do not throw it away!**

**This is a universal installation and operation instruction book which would apply to different models.**

**PLEASE READ!!!**

## FOR YOUR SAFETY

• **DO NOT STORE OR USE GASOLINE OR OTHER FLAMMABLE VAPORS OR LIQUIDS IN THE VICINITY OF THIS OR ANY OTHER EQUIPMENT.**

## WARNING

• **IMPROPER INSTALLATION, ADJUSTMENT, ALTERATION, SERVICE OR MAINTENANCE CAN CAUSE PROPERTY DAMAGE, INJURY OR DEATH.**

• **READ THE INSTALLATION AND MAINTENANCE INSTRUCTIONS THOROUGHLY BEFORE INSTALLING OR SERVICING THIS EQUIPMENT.**

• Electrical grounding instructions

This appliance is equipped with a three-prong (grounding) plug for your protection against shock hazard and should be plugged directly into a properly grounded three-prong receptacle. Do not cut or remove the grounding prong from this plug.

• Wiring diagrams are located in the control compartment area of the rotisseries.

• Have the equipment installed by a qualified installer in accordance with all federal, state and local codes.

• This equipment is for use in non-combustible locations only.

• Do not obstruct the flow of combustion and ventilation air.

• Do not spray controls or the outside of the equipment with liquids or cleaning agents

• Allow for hot parts to cool before cleaning or moving.

• This equipment should only be used in a flat, level position.

• Do not operate unattended.

• Any loose dirt or metal particles that are allowed to enter the gas lines on this equipment will damage the valve and affect its operation.

• If you smell gas, follow the instructions provided by the gas supplier. Do not touch any electrical switch; do not try to light the burner; do not use a telephone within close proximity.

• Never attempt to move grates while cooking.

## SET UP

1. Remove all packing material and tape, as well as any protective plastic from the equipment.
2. Place the equipment in the desired position and height.
3. Clean and dry the equipment thoroughly before using.

## INSTALLATION:

**The installation of this equipment must conform with local codes, or with *the National Gas Code, ANSIZ223.1/NFPA 54*, or the**

***Natural Gas and Propane Installation Code, CSA B149.1*, as applicable.**

**The appliance must be electrically grounded in accordance with the *National Electrical Code, NFPA 70*, or the *Canadian Electrical Code, CSA C22.2*.**

### **Installation with casters**

- i) the installation shall be made with a connector that complies with *the Standard for Connectors for Movable Gas Appliances, ANSI Z21.69-CSA 6.16*, and a quick-disconnect device that complies with the *Standard for Quick-Disconnect Devices for Use With Gas Fuel, ANSIZ21.41-CSA 6.9*;
- ii) adequate means must be provided to limit the movement of the appliance without depending on the connector and the quick-disconnect device or its associated piping to limit the appliance movement; and
- iii) the location(s) where the restraining means may be attached to the appliance shall be specified.

- The equipment and its individual shutoff valve must be disconnected from the gas supply piping system during any pressure testing of that system at test pressures in excess of ½ psi (3.5 kPa).
- The equipment must be isolated from the gas supply piping system by closing its individual manual shutoff valve during any pressure testing of the gas supply piping system at test pressures equal to or less than ½ psi (3.5 kPa).

#### **Clearance and positioning around the equipment:**

- This equipment must be installed adjacent to non-combustible surfaces only with a minimum spacing of 0" from all sides. This equipment must be a distance of 6" from other equipment.

#### **Air Supply and ventilation:**

- The area in front and around the equipment must be kept clear to avoid any obstruction of the flow of combustion and ventilation air.
- Adequate clearance must be maintained at all times in front of and at the sides of the equipment for servicing and proper ventilation.

#### **Pressure Regulator:**

- All commercial cooking equipment must have a pressure regulator on the incoming service line for safe and efficient operation. The regulator provided for this equipment is adaptable for both Natural gas and LP gas.
- Regulator specifications: ¾" NPT inlet and outlet, factory adjusted for 4" WC Natural Gas standard and may be converted by qualified personnel to be used for Propane at 10" WC.

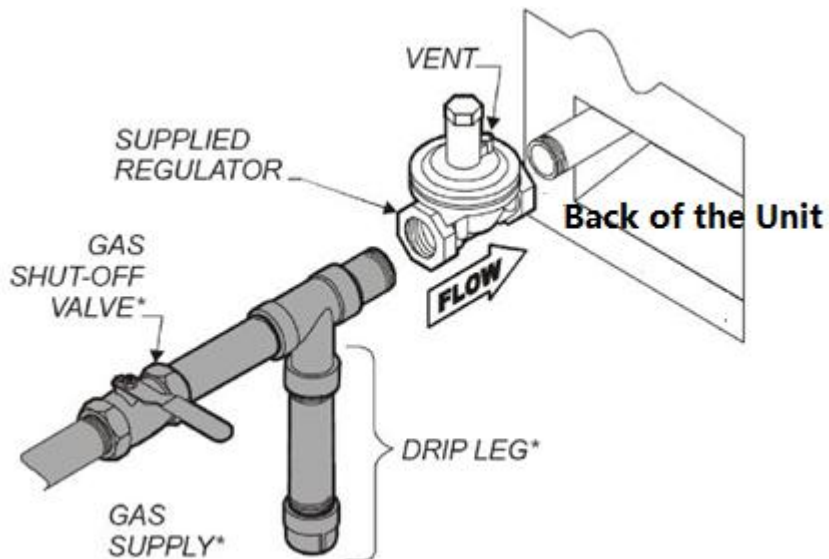

Prior to connecting the regulator, check the incoming line pressure. The regulator can only withstand a maximum pressure of ½ PSI (14" WC). If the line pressure is beyond this limit, a step down regulator before the regulator provided will be required. The arrow above (FLOW) shows gas flow direction and should point downstream to the equipment.

#### **PROPANE GAS CONVERSION**

This rotisserie is shipped from the factory equipped with fixed burner orifices for natural gas operation. The burner orifices required to convert the rotisserie to propane gas are shipped with the rotisserie in the shipping packaging. It is recommended that a trained gas service technician with the necessary tools, instruments and skills perform the conversion.

To convert to propane, following steps must be completed:

1. Remove all natural gas burner orifices and install the provided propane burner orifices.
2. Set the regulator to 10" W.C. by inverting the regulator spring plug like below pictures

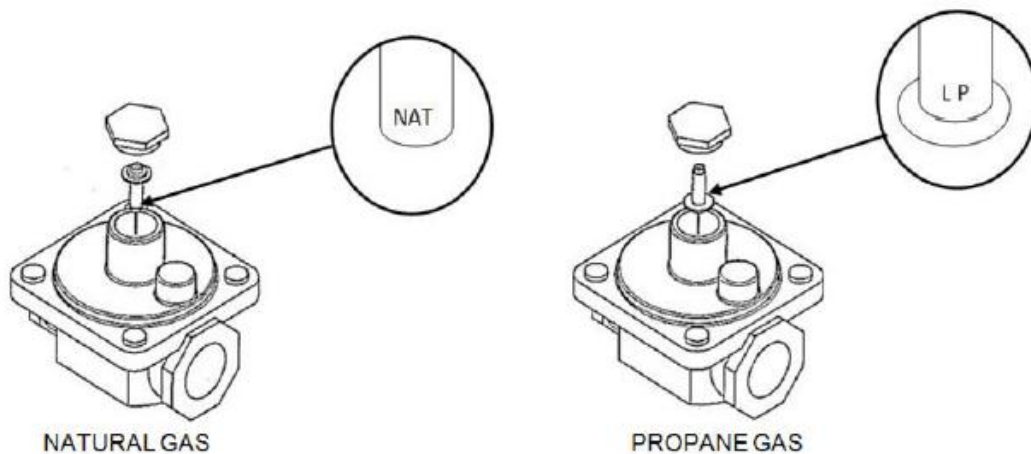

**OPERATION:**

Turn the main power switch ON. Each power switch controls each spit independently.  
 Allow the rotisserie to preheat for 30 minutes. Each spit is able to cook 5 chickens in 45 minutes.

**After 30 minutes of burn-in, equipment is ready for use.**

**OPERATION:**

1. To ignite the burners, depress and turn the gas control knob to high position.
2. Turn on the motor and chamber light switch when in need.

**SHUTDOWN INSTRUCTIONS:**

After cooking is done, please turn the valve to off position and turn off the motor switch, light switch and main power switch, then cut off the gas and power supply.

**COMPONENT PARTS**

The rotisserie comes with several standard parts as illustrated. Each can be easily removed and installed easily by hand for cleaning and maintenance. Note that the Burner and Deflector are an assembly and are NOT designed to be disassembled.

**CLEANING**

Spits may be immersed in strong commercial cleaning compound overnight. In the morning, rinse with hot water to remove any residues of cleaning compound. Thoroughly dry and apply cooking oil to prevent rusting.

Stainless steel surfaces may be cleaned using damp cloth with mild detergent and water solution. Places where fat, grease, or food can accumulate must be cleaned regularly.

**MAINTENANCE:**

- A qualified service company should check the unit for safe and efficient operation on an annual basis.
- Gas piping shall be a certain size and installed to provide a supply of gas sufficient to meet the full gas input of the equipment.
- A manual shut off valve should be installed upstream from the manifold within 4 ft. (1.2m) of the

equipment and in a position where it can be reached in the event of an emergency.

- Check entire gas piping system for leaks every so often. Using a gas leak detector or soapy water solution is recommended.
- Install equipment under efficient exhaust hood with flameproof filters with a distance of no less than 4 feet between the top of the equipment and the filters or any other combustible materials.
- \*Shipped setup for Natural Gas and includes a kit for conversion to LPG.

### LEVELING

It is important that the rotisserie is level front to back and left to right. Areas of uneven heat distribution will occur on an unlevelled unit. The unit should be rechecked for level anytime it has been moved.

### VENTILATION HOOD

The rotisserie should be installed under a suitable ventilation hood. For safe operation and proper ventilation, keep the space between the rotisserie and vent hood free from any obstructions.

PROBLEM	POSSIBLE CAUSES
Uneven heating, sides burning	<ul style="list-style-type: none"> <li>A. Burner valves improperly adjusted</li> <li>B. Fluctuating gas pressure</li> <li>C. Improperly adjusted burner</li> </ul>
Too much top heat	<ul style="list-style-type: none"> <li>A. Burner valves adjusted too high</li> <li>B. Faulty ventilation</li> <li>C. Overrated gas pressure</li> <li>D. Improperly adjusted burner</li> </ul>
Uneven heat side to side	<ul style="list-style-type: none"> <li>A. Burner valves improperly adjusted</li> <li>B. Appliance is not level side to side</li> <li>C. Improperly adjusted burner</li> </ul>
Yellow burner flames	<ul style="list-style-type: none"> <li>A. Open burner shutters until flames are blue</li> </ul>
Lifting burner flames	<ul style="list-style-type: none"> <li>A. Close burner shutters until flames touch burner</li> </ul>
Fluctuating gas pressure	<ul style="list-style-type: none"> <li>A. Check for clogged vent on regulator</li> </ul>

Product Specification Sheet

MODEL	Total B.T.U. per Hour	Voltage	Burner quantities	Motor quantities
RG4	38,000	120V/60Hz	1	4pcs
RG4-2	76,000	120V/60Hz	2	4pcs
RG7	114,000	120V/60Hz	3	7pcs

Wiring diagram

