

QCG SERIES ELECTRIC
Electric Convection Steamer
Quick Change Generators - Floor Based

MODELS

6 Pan Models: E6-32-ES E6-36-ES E6-32-CS E6-36-CS
10 Pan Models: E10-32-ES E10-36-ES E10-32-CS E10-36-CS

STANDARD FEATURES

- All 304 Stainless Steel interior and exterior construction including 14 Gauge construction of: Doors, Cooking Chambers and Front Lower Cabinet.
- Fully independent cooking compartments consisting of independent: steam generators, valves and electrical controls.
- Exclusive De-Lime Control Center featuring easy access and user-friendly fill ports and controls.
- Automatic Generator Blowdown and Flush system.
- Internal quick change high capacity, high volume water filter.
- Steam flow directed over pans from both left and right sides of cooking chamber through exclusive stainless steel spray jets for faster and more even cooking.
- Heavy duty refrigeration style door handles with magnetic latches.
- Each compartment has 1 (one) 60 minute timer with Manual Bypass mode for continuous steaming.
- Exclusive QCG (Quick Change Generator) System includes 2 (two) identical thickwall (7 Gauge 304 Stainless Steel) steam generators that can be easily replaced in less than 30 minutes.
- Steamer ON, READY, DE-LIME and WATER FILTER status indicators.
- 6" adjustable legs with flanged feet.
- UL Listed, UL Classified to NSF/ANSI 4 and exceeds Energy Star® performance levels.
- One year limited Parts and Labor Warranty included.

OPTIONS

- Extended Parts and Labor Warranty up to 2 years.

ACCESSORIES SOLD SEPERATELY

- Sterling De-Lime Solution, 6 one gallon container
- Sterling replacement Water Filter Cartridge



MODEL E10-32-ES208
Shown Above

SPECIFICATIONS

Two compartment electric convection steamer featuring all stainless steel construction and fully independent cooking compartments, steam generators, valves and electrical controls. QCG System includes two thickwall stainless steel quick change steam generators. De-Lime Control Center includes easy access to fill ports and controls. Automatic Generator Blowdown and Flush System. Internal quick change water filter. 60 minute timers with Manual Bypass mode for continuous steaming. Stainless spray jets for directing steam evenly over each pan from both sides. Heavy duty 14 gauge cooking compartments and exterior doors. 6 (six) inch adjustable legs with flanged feet included. Power required, 208 or 240VAC, 60Hz, 3 phase.

Exterior Dimensions:

6 Pan: 24"w x 37.2"d x 59.25"h.
 10 Pan: 24"w x 37.2"d x 66"h

UL Listed, UL Classified to NSF/ANSI 4 and exceeds Energy Star® performance levels.

QCG SERIES ELECTRIC

Electric Convection Steamer

Quick Change Generators - Floor Based

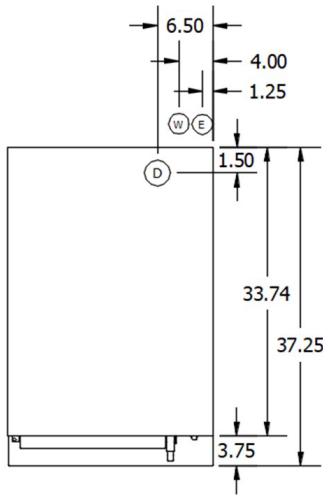

CAPACITY

6 Pan: Each compartment holds 3 (three) 12"x 20"x 2.5" cafeteria pans.
 10 Pan: Each compartment holds 5 (five) 12"x 20"x 2.5" cafeteria pans.

SERVICE CONNECTIONS

- (W) **WATER:** Cold, 30 - 60 PSI, 3/4" FNPT
- (E) **ELECTRICAL CONNECTION:** Single point supply 3/4" conduit.
- (D) **DRAIN:** 1-1/2" MNPT. Provide an open air gap type drain within 6' of connection to steamer to eliminate steam vapors entering unit from underneath. Do not connect solidly to any drain connection. Do not use PVC pipe.

NOTES:

- It is the responsibility of the owner and installer to comply with local codes for installation.
- This appliance is manufactured for commercial installation only and is not intended for household use.

WATER QUALITY REQUIREMENTS

TTDS:	50-250ppm
HARDNESS:*	3-12gpg
ph RANGE:	7-8.5
TOTAL CHLORINE:	less than 4 ppm
SILICA:	less than 13 ppm

* 17.1 ppm = 1 grain

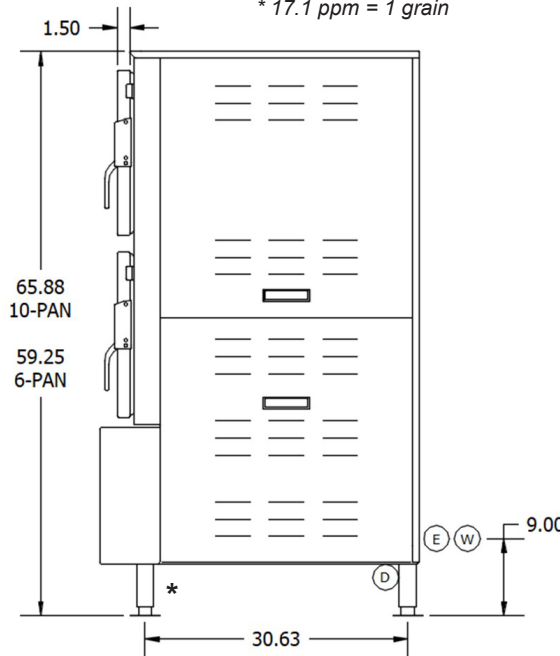
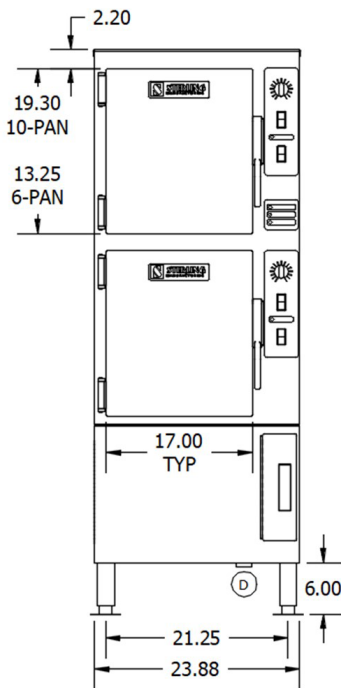

* Legs adjust from 6" - 8" (152 - 203mm)

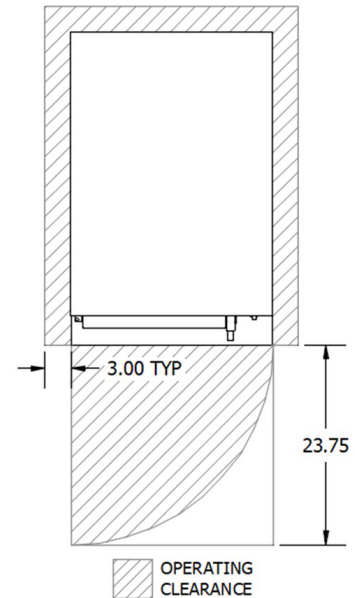

Model Number	Volt/Hz/Phase	kW	Amps
STERLING QCG Series EnergyStar 6 Pan			
E6 - 32 - ES208	208/60/3	32	89
E6 - 36 - ES208	208/60/3	36	100
E6 - 32 - ES240	240/60/3	32	77
E6 - 36 - ES240	240/60/3	36	87
STERLING QCG SERIES EnergyStar 10 Pan			
E10 - 32 - ES208	208/60/3	32	89
E10 - 36 - ES208	208/60/3	36	100
E10 - 32 - ES240	240/60/3	32	77
E10 - 36 - ES240	240/60/3	36	87

Model Number	Volt/Hz/Phase	kW	Amps
STERLING QCG Series Conventional 6 Pan			
E6 - 32 - ES208	208/60/3	32	89
E6 - 36 - ES208	208/60/3	36	100
E6 - 32 - ES240	240/60/3	32	77
E6 - 36 - ES240	240/60/3	36	87
STERLING QCG SERIES Conventional 10 Pan			
E10 - 32 - ES208	208/60/3	32	89
E10 - 36 - ES208	208/60/3	36	100
E10 - 32 - ES240	240/60/3	32	77
E10 - 36 - ES240	240/60/3	36	87

Sterling Mfg., LLC reserves the right to design improvements or modifications, as warranted.



SMSD - SD011723

Page 2 of 2