

FlamBoyant™ FB1400-8E

DESIGN

The FlamBoyant range of rotisseries has been especially designed for high-volume cooking with high output and speed, while retaining excellent cooking quality. In addition, a wide array of accessories enable the rapid roasting of a variety of products.

Well designed, user friendly and reliable, the FlamBoyant is used by leading supermarkets and chain restaurants throughout the world.

FEATURES



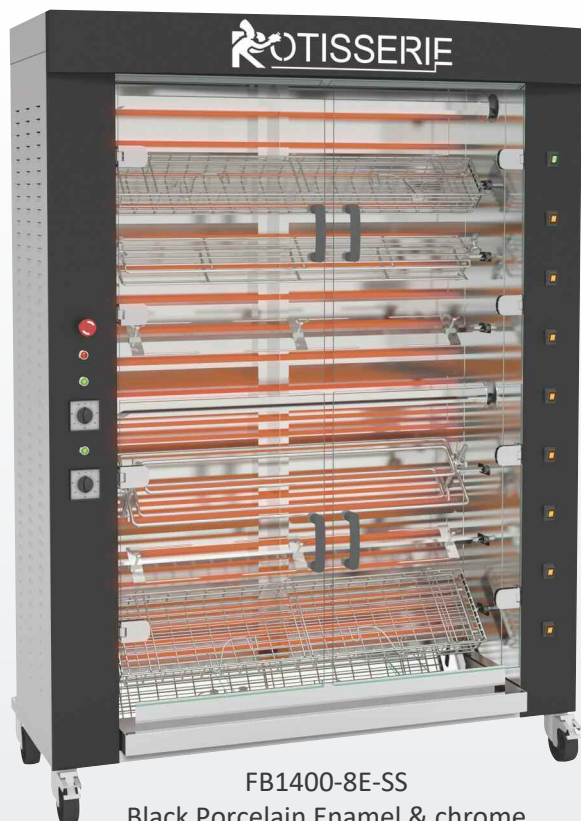

- Energy efficient
- Tempered K-glass doors
- Independent motor for each spit
- Equipped with bottom drip tray with built-in drainage
- Reinforced and anti-warping heating element
- Powerful halogen lamp
- Delivered with 8 prongless chicken spits (CUI1375-1400)
- Illuminated "Rotisserie" sign for enamel model only (optional)
- Base or stand on casters with brakes (optional)

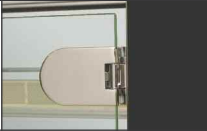
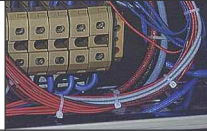

FB1400-8E-SS
Black Porcelain Enamel & chrome
shown with optional lighted roof

TECHNICAL DETAILS

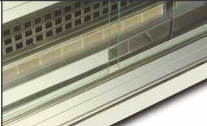
Overview of some of the standard features.

	Independent motors adjustable in depth for each spit.		Robust hinges designed for heavy use, with integrated locking in open and closed positions.		Easy and protected access to the compartment of connections and electrical components.
	Reinforced heating elements with stainless steel holders to keep them in place and removable stainless steel panels for easy cleaning.		Anti-scald K-glass reduces external thermal radiation (energy saving). Glass overlaps drip pan to keep splatters inside (anti-slip protection).		Removable inside side-panels doubles protection from grease seeping into motors and other sensitive parts.

ACCESSORIES

A variety of accessories are available. See video of available accessories and of vertical spit system online.

CUI1375-1400 Anti-cutting prongless V-spit		BPOR1375-1400 Porchetta spit		BRC1375-1400 Rectangular basket spit	
BS1375-1400 Spit for ham / turkey		BRRO1375-1400 Roast-clamp spit		BA1375-1400 Lamb/suckling-pig spit	
BCR1375-1400 Spatchcock chicken basket		DEC Spit mover		PID1375-1400 Tray for unspitting	

Front view
Rotisserie with roof

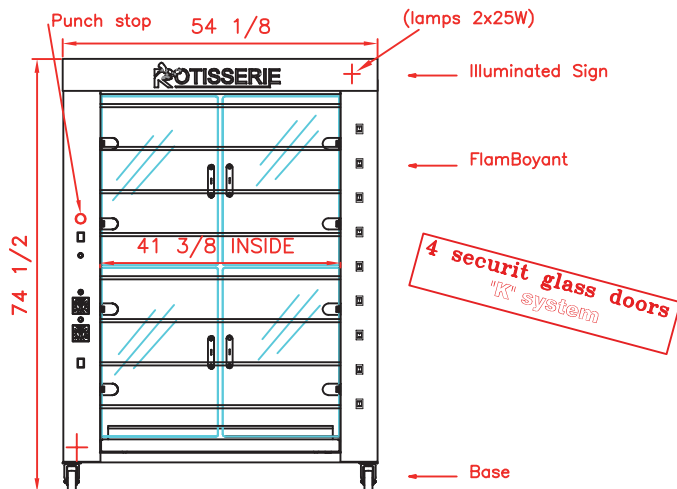

Top view
Rotisserie with roof

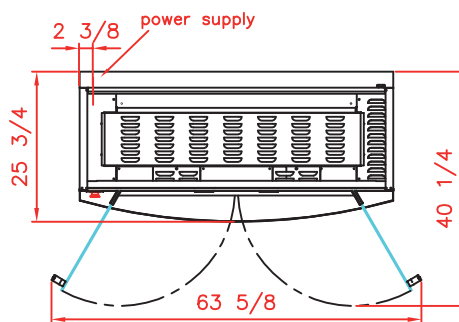

Side view
Rotisserie with roof

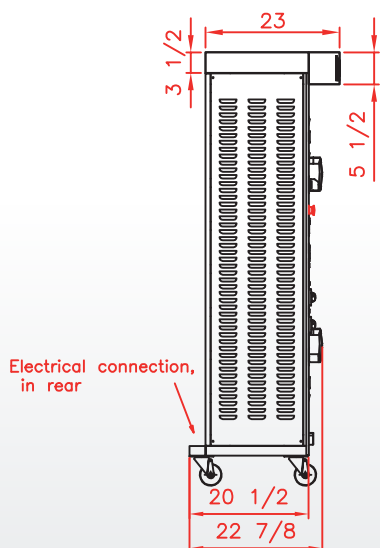

Revised
June 2021
April 2022 US

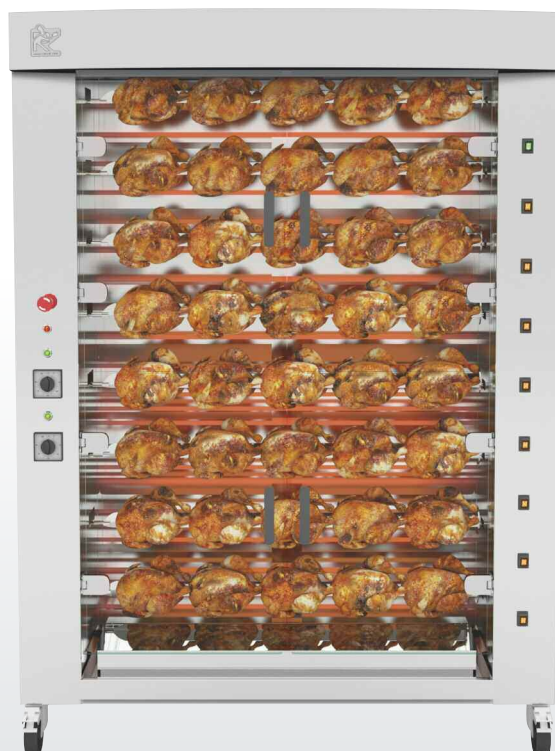

FB1400-8E-SS
Stainless steel

SPECIFICATIONS

Capacity roasted chickens	40/48 chickens
Power supply	208-240V-60Hz ; 3 Phases + Earth
Electrical power	101 Amps ; 36,2 kW
Weight and size (HxDxW)*	530 Lbs ; 74 1/2 x 25 3/4 x 54 1/8 inches
Shipping weight and size*	664 Lbs ; 74 7/8 x 30 3/8 x 58 1/4 inches
Warranty	1 year parts and labor

* with a stand or base cabinet (optional)

DISTRIBUTOR / AGENT

Rotisol France, Inc.
1450 W. 228th St. Unit 10, Torrance, CA 90501
info@rotisolutusa.com
Ph: 310 671 7254
800 651 5969

