



Founded in 1946

Project: \_\_\_\_\_

Items: \_\_\_\_\_

Quantity: \_\_\_\_\_

Approval: \_\_\_\_\_

Date: \_\_\_\_\_

FULL / HALF SIZE CAN RACKS

## Full / Half Size Can Racks

Easily store, restock, and transport cans with the Full and Half Size Can Racks. Utilize space under tables with the half height design.

### Features:

- All welded aluminum and stainless steel construction options available
- **Lifetime Warranty Against Rust**
- Holds #10 & #5 cans
- Half height unit work tops available in aluminum, stainless steel, or poly top
- Mobile units are easily maneuvered on polyurethane (2) 5" locking swivel casters and (2) 5" rigid casters

### Benefits:

- Organizes can stock and maximizes available space.
- Self-feeding feature keeps stock rotated.
- Half height mobile units double as a work station
- Maintains sanitary environment in the kitchen
- Aluminum and stainless designs are sturdy and reliable.
- Safely and efficiently transport items with our mobile units.
- Half height mobile units are designed for low volume locations that do not need a full size rack.
- Ensures conformance to FDA rule that requires the storage of all fresh produce be at least 6" above the floor.

CR-162

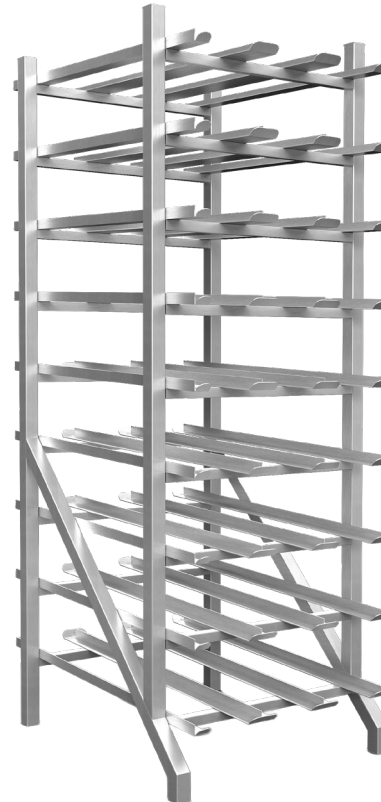

CR-72S-S





Founded in 1946

# Full / Half Size Can Racks

**CR-162 Specs**

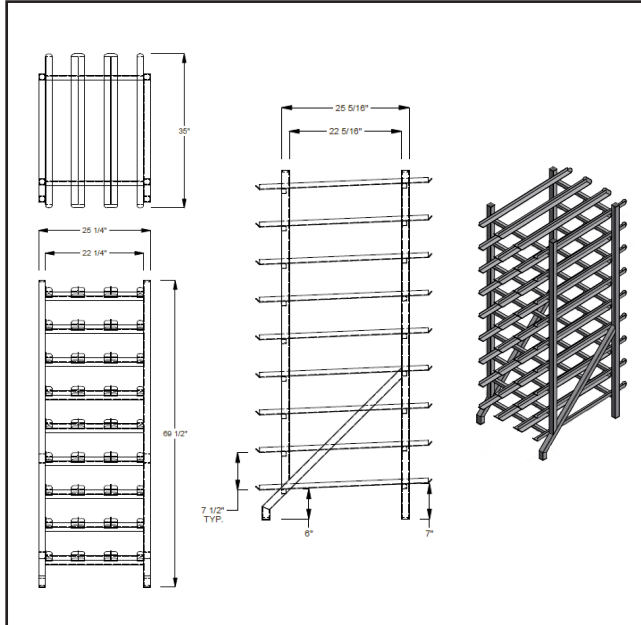

**CR-72S-S Specs**

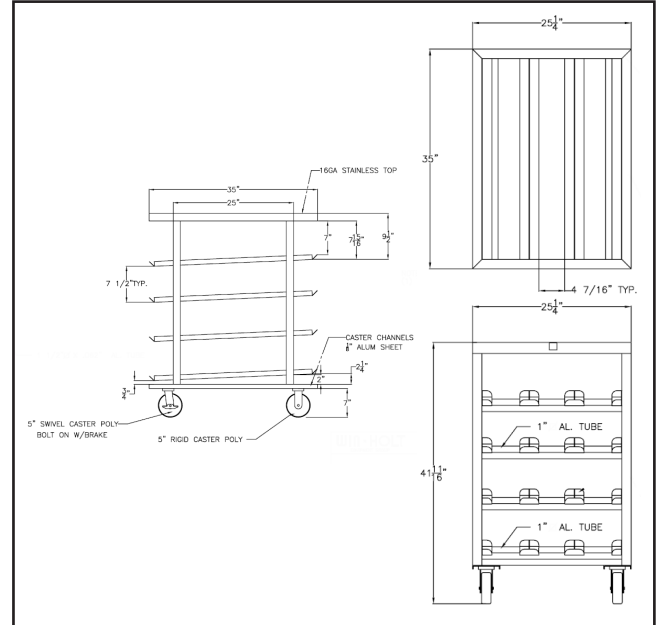

Model Number	Order #	Type of Unit	Overall Dimensions			Can Capacity		Approx. Ship Wt (lb)
			Width	Length	Height	#10	#5	
			(in)	(in)	(in)			
<b>Full Height Units</b>								
CR-162	112491	Stationary	25 1/4	35	71	162	216	60
CR-162AJ	112504	Adjustable Feet	25 1/4	35	71	162	216	60
CR-162M	112512	Mobile	27 1/2	35	76	162	216	66
<b>1/2 Height - Mobile Units</b>								
CR-54M	112521	Aluminum Top	27 1/2	35	35	54	72	50
CR-54PT	112547	Poly Top	27 1/2	35	35	54	72	65
CR-54S-S	112555	Stainless Steel Top	27 1/2	35	35	54	72	42
CR-72M	112563	Aluminum Top	27 1/2	35	40	72	96	58
CR-72PT	112571	Poly Top	27 1/2	35	40	72	96	72
CR-72S-S	112580	Stainless Steel Top	27 1/2	35	40	72	96	62
<b>1/2 Height - Stationary Units</b>								
CR-54	1155657	Aluminum Top	25 1/4	35	32 1/2	54	72	50
CR-54PT-ST	1155659	Poly Top	25 1/4	35	32 1/2	54	72	50
CR-54S-S-ST	1155658	Stainless Steel Top	25 1/4	35	32 1/2	54	72	50

**Caster Information for Mobile Units:**  
 (2) 5" Rigid Polyurethane Casters 743A  
 (2) 5" Swivel Polyurethane Casters 738W  
**Freight Class: 250**

**Option for CR-162M:**  
 PP Prison Package



In line with our policy to continually improve our products, Winholt reserves the right to change materials and specifications without notice.