



Project Name: _____

Location: _____

Item #: _____

Qty: _____

General 48" Gas Radiant Charbroiler, 8 Burners, in Stainless Steel

GCRB-48NGS



Bring authentic grilled flavor and professional performance to your kitchen with the General 48" Gas Radiant Charbroiler. This commercial gas radiant charbroiler is designed for restaurants, cafes, and catering operations that demand consistent results and reliable power. With an impressive 160,000 BTUs, this heavy-duty stainless steel charbroiler delivers the heat needed to maintain optimal cooking temperatures, ensuring that your dishes are cooked to perfection every time. It is ideal for grilling burgers, chicken, steaks, seafood, vegetables, and more.

FEATURES AND CONSTRUCTION

- Constructed from stainless steel for durability
- Delivers 160,000 BTUs of high-performance cooking power
- Features 8 burners for versatile cooking options
- Compact design is ideal for small kitchens and food trucks
- Equipped with four adjustable legs for stability
- Has 8 gas conversion orifices
- Manual ignition and control type for precise cooking
- Delivers consistent cooking with a wide temperature range
- Easy-to-clean removable drip tray enhances maintenance
- Designed for commercial use in busy kitchen environments

3RD PARTY APPROVALS

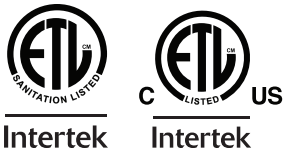

WARRANTY (USA / CANADA)

1 year parts and labor

Contact General for details at info@generalfoodservice.com or 954.202.7419



INCLUDED COMPONENTS

- (4) Adjustable Legs
- (8) Gas Conversion Orifices
- (1) Relief Valve
- (2) Drip Tray
- (1) Raised Grill Plate



General 48" Gas Radiant Charbroiler

GCRB-48NGS

FRONT

SIDE

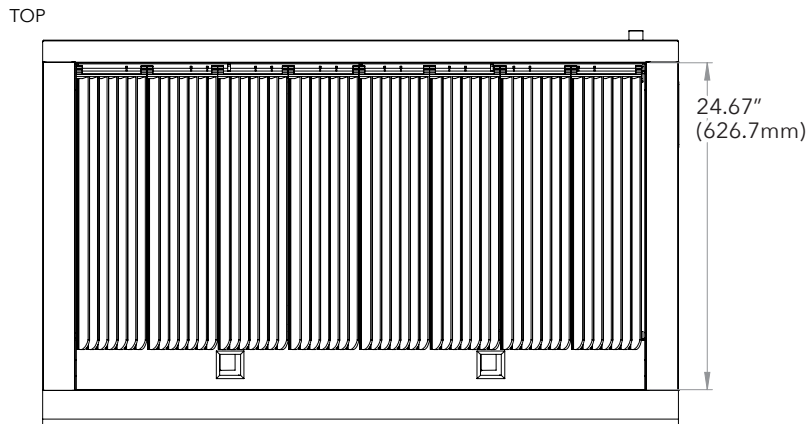
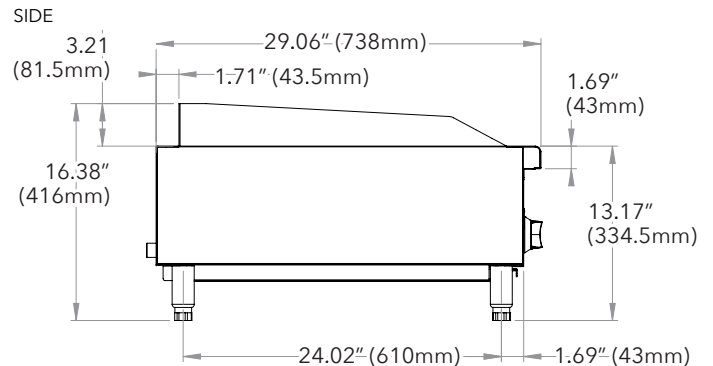
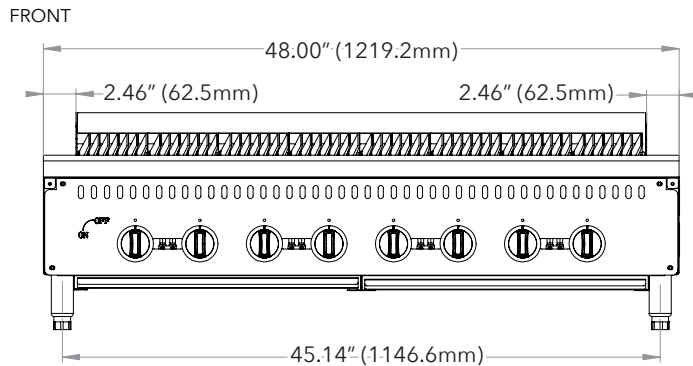

TOP

Gas

Ignition Type	Total BTU/hr	Total Number of Burners	Cooking Surface	Number of Drip Trays	Assembled Dimensions (in)	Item Weight (lbs)	Shipping Weight (lbs)
Manual	160,000	8	Cast Iron	2	29.06" x 48.00" x 16.38"	198.5	255.8

Due to periodic changes in designs, methods, procedures, policies and regulations, the specifications contained in this document are subject to change without notice. While we exercise good faith efforts to provide information that is accurate, we are not responsible for errors or omissions in information provided or conclusions reached as a result of using the specifications. By using the information provided, the user assumes all risks in connection with such use.