



Founded in 1946

A Wide Range of Solutions. A World of Possibilities.

PRODUCT CATALOG

Stainless Steel Fabrication
Foodservice & Restaurant Chains
Supermarket & Retail
eCommerce & Home Delivery
Material Handling
Distribution Centers
Home Centers



ALL NEW EQUIPMENT SOLUTIONS

WLFD-WRKSTN-2



WLFD-WRKSTN-1



STAINLESS STEEL MOP CABINETS

- Sanitary solution for keeping your cleaning station contained and cleaning supplies stored.
- All welded stainless steel design with shelves for storage, hinged doors, a 15° slanted top and vents on the back/sides of unit.
- **Find on Page 25**

STCT-HD2450.5H84-MPS-ST-KT



STAINLESS STEEL WORK STATIONS



- These Multi-Use Work Stations create a computer desk, utility workspace, or storage space in any section of your facility.
- All welded stainless steel construction with (2) hinged doors and adjustable bullet feet.
- Convenient cable hole design
- **Find on Page 128**



STCT-HD2425H84-MPS-ST-KT



WS1T5714DP12-KT

STAINLESS STEEL TROUGH SINKS



- Winholt Trough Sinks provide an efficient multi-user solution for high-traffic handwashing and utility areas in commercial kitchens and backrooms.
- All welded 16-gauge stainless steel construction with integrated 10" backsplash and faucet cutouts.
- Includes a 14"W x 12"D basin with a 3½" center drain and removable strainer basket.
- (2) Z clips included for wall-mount installation.
- Adjustable bullet clad feet for leveling on uneven surfaces.
- **Find on Page 25**

STAINLESS STEEL WALL PANELS



- Stainless Steel Wall Panels upgrade your kitchen with a sleek, sanitary surface that installs easily using a divider system.
- Constructed from 18-gauge stainless steel for strength and durability.
- Easy-to-clean surface reduces maintenance and supports high-use environments.
- Panels slide in seamlessly for quick installation and integration with other stainless steel fixtures.
- Modern design enhances any workspace.
- **Find on Page 58**



ADJUSTABLE STAINLESS STEEL TABLES



DTS-3060H32-ADJ-9

- Ergonomically designed with your team in mind, these stainless steel tables feature an adjustable height range, allowing for every associate to work comfortably.
- All-welded stainless steel design with SS top, poly-top, undershelf, and cross rail options.
- Height adjusts up to 9" (from 32" to 41") in just 35 seconds, effortlessly adapting to every task.
- Heavy-duty weight capacity of 1300 lbs ensures reliable performance for even the most demanding work environments.
- **Find on Page 52**



DTS-3060H32-ADJ-9-PT



INHPL-2416-PBCAB-DGT

INSULATED PASS-THROUGH HEATER PROOFER



- This unit bridges the gap between kitchen prep and front-of-house service or to-go fulfillment.
- Pass-through design with wide-opening doors makes it easy to load and retrieve orders quickly.
- Durable aluminum build with corner bumpers for protection in busy spaces.
- Dual proof/heat modes with precise digital controls keep food fresh and ready.
- Holds up to 16 pans
- **Find on Page 60**



SS-BC-2748-INSULIB-TOS

GRAB & GO MERCHANDISER KIOSK STAINLESS STEEL CARTS



- Perfect for grab-and-go and impulse sales, designed for event centers, schools, retail, foodservice, and hospitality. The Winholt sleek stainless steel kiosks attract attention and keep cold items easily accessible.
- Durable, all-welded stainless steel construction supports magnetic branding and logos for a customizable, professional look.
- Insulated 8" deep removable ice bin with recessed drain holds (3) standard 12" x 20" pans (not included).
- Includes a removable stainless steel cover with bumpers and a built-in hook for convenient storage.
- **Find on Page 82**



Shown with
18" Folding
Shelf



SS-BC-2748-INSULIB-FS18



ALL NEW EQUIPMENT SOLUTIONS



AL-1310-DBL-HD-ST

DOUBLE RACK



- Double your capacity, not your footprint – This space-saving aluminum double rack holds (up to 20) 1/2, 1/3 and 2/3 size pans
- Durable, rust-proof construction backed by a lifetime warranty.
- Solid top and reinforced uprights add strength and stability.
- Two columns with 10 runners each (6 1/2" spacing) fit standard 12" x 20" pans.
- **Find on Page 80**

SLANTED RACK



- Slanted design with upright supports keeps boxes, crates, and lugs stable on the move.
- Secure, efficient transport for kitchen essentials
- All-welded aluminum construction built for durability in demanding environments.
- 4 shelves per side with 13 1/8" runner spacing, sized for items up to 12"W x 15"L x 13 1/8"H.
- Adjustable feet ensure stability on uneven surfaces.
- **Find on Page 80**



AL-1104-2S-ST

Aluminum Top
Folds when
Nesting



ALUN-2721N-DD

TRANSPORT NESTING RACK



- Designed for high-traffic environments, this nesting rack streamlines pan transport and storage with ease.
- All-welded aluminum construction with an aluminum top, poly drip-tray, and a rear tray stop for secure loading.
- Nests compactly for efficient storage; includes clips for added stability during transport.
- 21 Runners that accommodate a variety of pan sizes with varying runner spacing.
- **Find on Page 74**

FIFO CAN DISPENSING RACK



- This can rack ensures first-in, first-out rotation to keep inventory fresh and minimize waste.
- Built tough with all-welded aluminum construction for long-lasting performance.
- Holds standard #10 and #5 cans across 3 columns and 8 FIFO rows.
- Adjustable feet for stability on any surface.
- **Find on Page 76**



CR-156F-BUC

CMFC-4442



ADJUSTABLE 3 TIER RISER

- Built to adapt, this display rack features adjustable shelves that make product access easy and efficient.
- All-welded steel construction with expanded metal shelves for durability and airflow.
- Ideal for showcasing plants, pots, and garden goods. Our mesh design allows for drainage and visibility, perfect for vibrant, eye-catching displays.
- **Find on Page 134**

DESIGNING SUPERIOR ENGINEERED SOLUTIONS

For over 80 years, Winholt has been a leading U.S. manufacturer with a global supply chain, delivering innovative, high-quality products backed by trusted service and deep industry expertise. Headquartered in Woodbury, NY, Winholt operates three national manufacturing facilities in Pennsylvania, Texas, and California.

This strategic footprint enables us to optimize U.S. manufacturing efficiencies, shorten lead times, reduce supply chain costs, and expedite delivery.

Our team is committed to providing Engineered Solutions—tailored products designed to enhance operational efficiency and drive cost savings. We proudly offer a Supply Chain Advantage to the industries we serve. ■ ■

OUR VISION

We are committed to supporting our customers, associates, suppliers, and communities with integrity and care, while striving to lead the industry through innovation and excellence in equipment solutions. ■ ■

OUR MISSION

Our experienced team is committed to delivering value-engineered solutions that reflect our 'We Care' culture and prioritize customer satisfaction. ■ ■

OUR PEOPLE

Winholt's dedicated associates have been the driving force behind our continued success. Their commitment reflects the strength and resilience of our company. At Winholt, we embrace a "We Care" culture, striving to lead by example in how we serve our customers, support our associates, collaborate with suppliers, and give back to our community. ■ ■



SYSTEMS & TECHNOLOGY

At Winholt, we're always working to enhance your experience. Our industry-leading Enterprise Resource Planning (ERP) system streamlines our operations, helping us deliver greater efficiency, productivity, and service excellence.

To make doing business with us even easier, we offer onboarding with Electronic Data Interchange (EDI), enabling faster, more accurate processing of purchase orders and invoices. We also support GS1 US system standards, ensuring unique and consistent product identification across your supply chain.

These innovations are part of our commitment to meeting—and exceeding—your expectations. ■ ■



Heater Proofers

ROBOTIC WELDING

Our robotic welding systems enhance production efficiency through exceptional speed, precision, and consistency.

We integrate custom-fabricated, laser-cut, and formed components to deliver advanced, high-quality assemblies to our customers. ■ ■



LASER, CNC CUTTING & PUNCH PRESS

By minimizing setup times and enhancing productivity, our manufacturing process supports high-volume production of diverse components. It consistently delivers high-precision parts with speed and efficiency. ■ ■



MANUFACTURING CAPABILITIES

DESIGN & 3D CAD

Our engineers use advanced 3D computer-aided design (CAD) tools to develop precise, visually accurate product models. We help you explore ideas, share concepts, and simulate real-world performance, long before production begins. ■ ■

MANUFACTURING

We specialize in precision manufacturing using advanced, state-of-the-art equipment. Our comprehensive capabilities include:

- CNC Automated Punch Cutting
- Robotic Welding
- Laser Cutting
- CNC Forming and Bending
- 3D CAD Design and Modeling
- Powder Coating

With a focus on quality and innovation, we deliver reliable, high-performance solutions tailored to your needs. ■ ■



MATERIALS

What sets us apart is our commitment to excellence, using top-grade 300 series stainless steel in 16 and 14 gauge, along with versatile aluminum and steel manufacturing solutions. ■ ■

QUALITY

After welding, each product undergoes thorough polishing, with seam edges and welds buffed to a bright, clean finish. We conduct a detailed quality inspection to ensure every item meets exact specifications before it is carefully crated and shipped. ■ ■

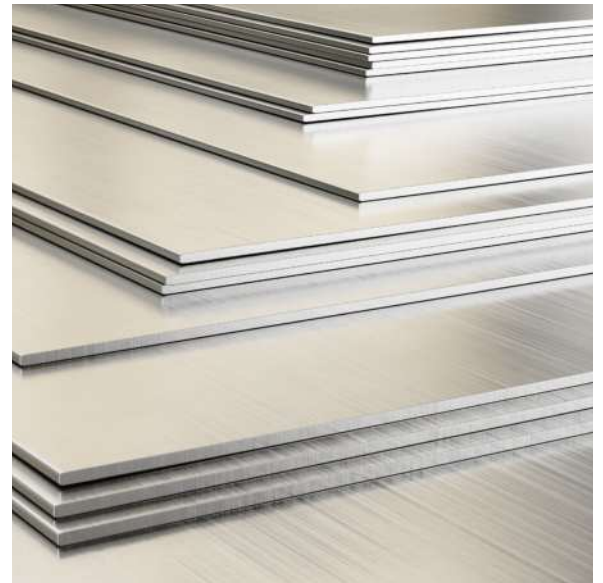

INDUSTRIES SERVED

Winholt is a global manufacturer of high-quality equipment solutions designed to support foodservice, restaurant chains, food handling, e-commerce, supply chain operations, distribution centers, and material handling. Our products help streamline operations for **supermarkets, retailers, restaurant chains, schools, supply chain and e-commerce businesses.** ■ ■



INDUSTRY MEMBERSHIPS & AFFILIATIONS



OUR LOCATIONS

As a multi-facility manufacturer, Winholt is equipped to respond swiftly and adapt across our entire organization. Each of our plants operates under lean manufacturing principles, prioritizing quality, flexibility, and cost-efficiency to ensure optimal performance.

Our facilities are capable of producing custom solutions in stainless steel, aluminum, and steel, offering versatility to meet diverse customer needs. We continually invest in advanced automation technologies to enhance our U.S. manufacturing capabilities—resulting in greater efficiency and reduced lead times. ■ ■

Woodbury,
New York



Dallas, Texas



Ontario, California



Allentown,
Pennsylvania

EXPRESS SHIPPING

On-time and reliable shipping is important to our team.

Our **Express Ship Program** ships in 2-3 business days.

Equipment available to ship express are marked

with:  and 



TABLE OF CONTENTS

STAINLESS STEEL FABRICATION 9-58	SHELVING..... 95-108
Custom Fabrication	Cantilever Shelving Kits
Compartment Sinks	Cantilever Shelving Build-it-Yourself
Specialty Sinks	Adjustable Shelving
Compartment Sink Modifications	Cooler & Backroom Shelving
Hand Sinks	Mobile Cooler Shelving
Mop Sink Cabinets	Adjustable Shelf Mobile Cooler Shelving
Mop Sinks	Correctional Shelving
Trough Sinks	Keg Racks
Drop-In Sinks	Aluminum Cooler Shelving
Dishtables	Dunnage Racks
Sorting Shelves	Economy
Dishtable Modifications	Heavy Duty
Faucets & Parts	Plastic
Work Tables	Gusset Leg
Enclosed Base Tables	E-COMMERCE & DISTRIBUTION 109-116
Table Options	Fork-Liftable Caged Carts
Table Modifications	Fork-Liftable Order Picking Tables
Workstation Shelving	Distribution Tow Carts
Beverage Counters	On-Line Order Picking Work Station
Dish Cabinets	Ladder Carts
Hybrid Tables	U-Boat Picking & Stock Cart
Adjustable Tables	Slanted Shelf Picking Cart
Fill Tables	Tow Picking Cart
Equipment Stands	Mobile Caged Transport Cart
Wall Shelves	Picking Shelf Carts
Wall Mounted Cabinets	Adjustable Picking Cart
Microwave Shelves	Order Picking Curbside Pickup Delivery Cart
Pot Racks	MATERIAL HANDLING
Floor Troughs	EQUIPMENT &
Wall Panels	WAREHOUSE STORAGE..... 117-130
HEATER PROOFERS & CABINETS 59-66	U-Boats
Pass-Through Heater Proofer	Ladder Truck
Universal Heater Proofers	Utility Cart
Non-Insulated Heater Proofers	Stocking & Marking Carts
Standard	Wet Produce Carts
Economy	Hand Truck
1/2 Height Under the Counter	Sani Stock Cart
Insulated Heater Proofers	Security Cages
Enclosed Mobile Transport Cabinets	Lockers
FOODSERVICE RACKS	Locker Options
& MOBILE STORAGE.....67-86	Work Stations
Knock-Down Pan Racks	Receiving Desks
Medium Duty Pan Racks	HOME CENTER & GARDEN..... 131-134
Heavy Duty Pan Racks	Steel Deck Cart
XTRA Heavy Duty Pan Racks	Customer Wagon
Half Size Pan Racks	Customer Diamond Deck Cart
Universal Pan Racks	Sheet Cart
Roll-In Refrigerator Pan Racks	Customer Lumber Cart
Channel Pan Racks	Adjustable 3 Tier Riser
Wire Pan Racks	Steel Utility Cart
Nesting Racks	SMALLWARES & ACCESSORIES.....135-140
Stainless Steel Pan Racks	Platters & Trays
Can Racks	Bagel, Bread and Bun Baskets
Steam Table Racks	Bagel Boards
Pizza Pan Rack	Cutting Boards & Replacement Poly Tops
Donut Screen Racks	Merchandise Display Stand
Oven Racks	Lugs
Reach-In Fridge Racks	Stack and Nest Containers
Double Rack	Bakery Rack Covers
Slanted Rack	REPLACEMENT PARTS
Queen Mary Banquet Carts	& WHEELS..... 141-146
Stainless Steel Utility Carts	Film Wrapper Parts
Grab & Go Merchandiser Carts	Heater Proofer Parts
Chicken Breeding Work Station	Wheels & Casters
Mobile Landing Table	ORDERING TERMS
Ingredient Bins	& WARRANTY..... 147-150
Rotisserie Storage Transport Rack	General Ordering Information
Sheet Pan Trucks	Conditions of Sale
Dollies	Statement of Warranty
Flat Bed Carts	
SUPERMARKET & FOOD HANDLING.....87-94	
Lug Carts	
Bulk Movers	
Platter Carts	
Universal Carts	
Crisping Rack	
Insulated Table Grab & Go Merchandisers	
Film Wrapper	

STAINLESS STEEL FABRICATION

- Custom Fabrication
- Compartment Sinks
- Specialty Sinks
- Compartment Sink Modifications
- Hand Sinks
- Mop Sink Cabinets
- Mop Sinks
- Trough Sinks
- Drop-In Sinks
- Dishtables
- Sorting Shelves
- Dishtable Modifications
- Faucets & Parts
- Work Tables
- Enclosed Base Tables
- Table Modifications
- Workstation Shelving
- Beverage Counters
- Dish Cabinets
- Hybrid Tables
- Adjustable Tables
- Fill Tables
- Equipment Stands
- Wall Shelves
- Wall Mounted Cabinets
- Microwave Shelves
- Pot Racks
- Floor Troughs
- Wall Panels



BRINGING GREAT DESIGN STAINLESS STEEL FABRICATION

Since 1946, we've been committed to delivering high-quality products and reliable service that help you reduce costs, optimize your national supply chain, boost productivity, and maintain superior sanitation standards in your workspace.

We create work environments that are both visually appealing and highly functional, designed to enhance workflow and streamline operation.

WE DESIGN & BUILD TO YOUR SPECIFICATIONS

We tailor each build to your unique operational needs, ensuring seamless fit and performance. Our team is focused on detail, delivering globally recognized quality, backed by NSF certification and ETL pre-wiring for reliability and compliance with standard regulations.

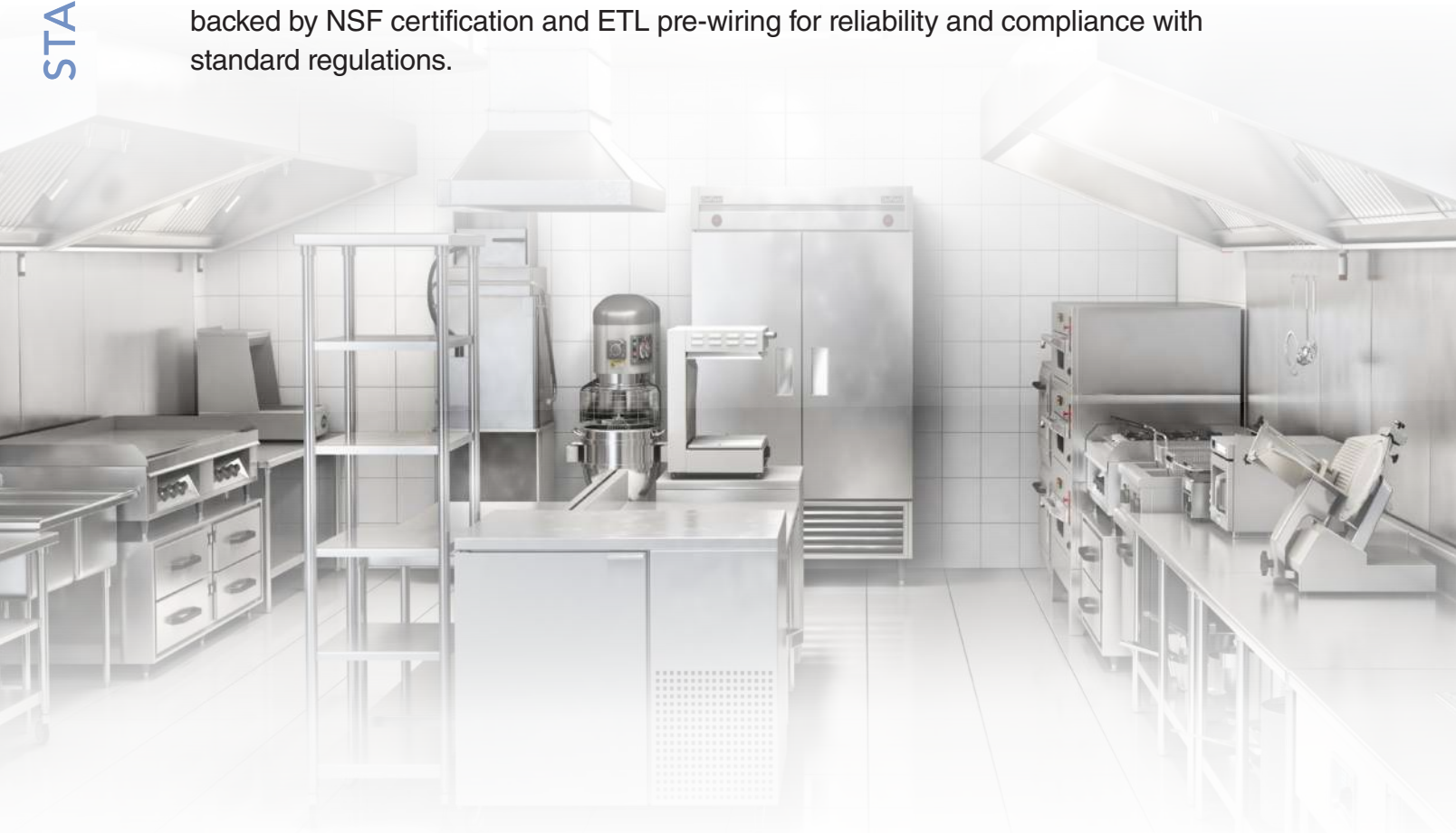

E-SERIES ETL PRE-WIRING • CHEF COUNTERS • SINKS • WORK TABLES • DISH TABLES
WALL SHELVES • WALL MOUNTED CABINETS • ENCLOSED TABLES • BEVERAGE COUNTERS
EQUIPMENT STANDS • OVER SHELVES & POT RACKS

CUSTOM STAINLESS STEEL FABRICATION WE'RE ELECTRIC!



The

E•SERIES

from WINHOLT

At Winholt, we specialize in premium custom stainless steel fabrication, complemented by a full line of commercial sinks, tables, cabinets, and more. Driven by innovation and built with your needs in mind, we're proud to offer electric solutions, expanding our capabilities to power the future of your facility. Call today to learn more about our complete line of stainless steel fabrication along with the new E-Series from Winholt... ***it's electrifying!***

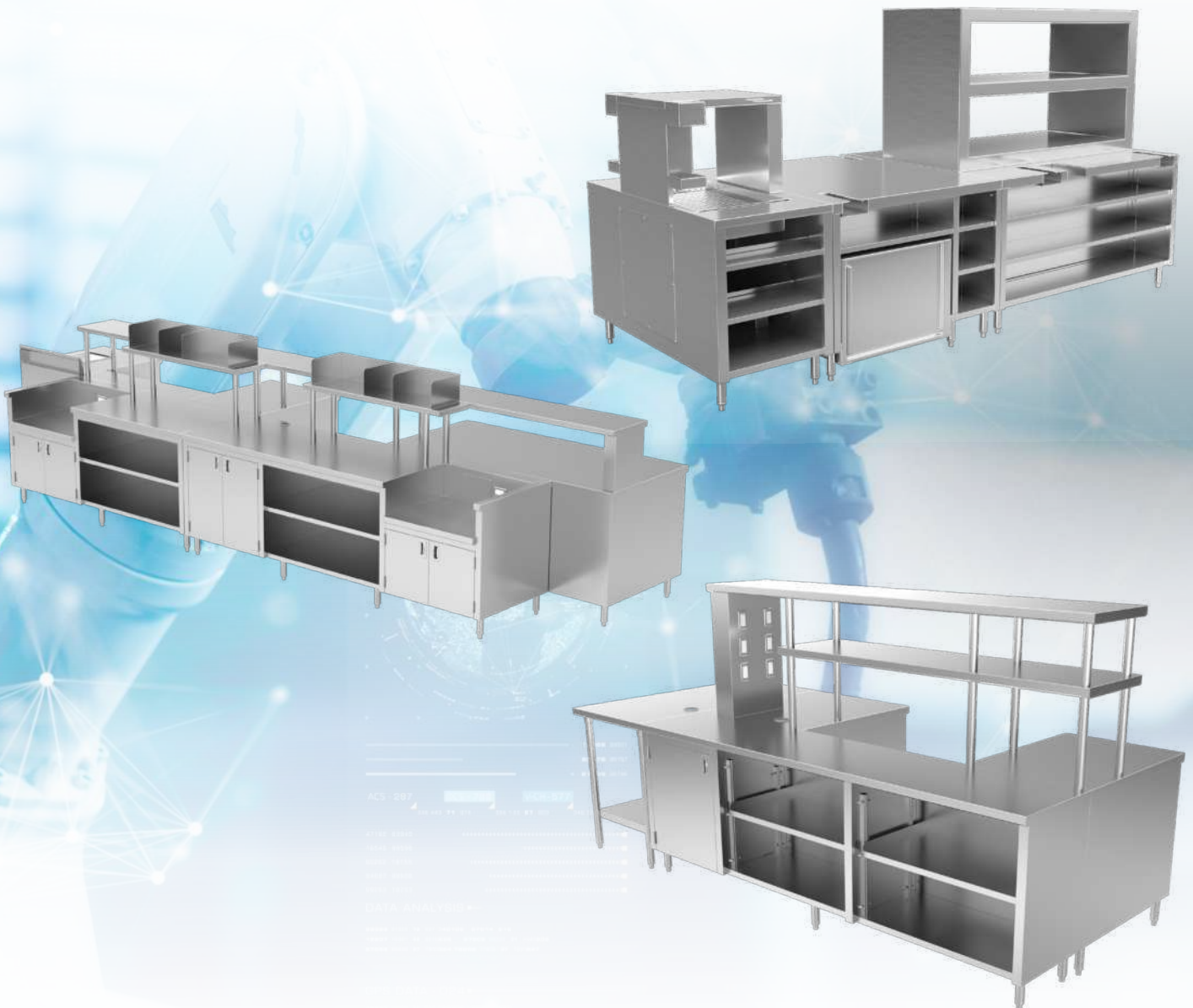



With decades of industry expertise, Winholt empowers your operations with smart, adaptable solutions tailored to meet the demands of modern foodservice environments.

Our thoughtfully engineered spaces support seamless operations, helping your team work more efficiently while maintaining a polished, professional atmosphere.

STAINLESS STEEL

We set ourselves apart using superior-grade materials, exclusively 16 and 14 gauge, 300 series stainless steel. While others use materials that easily rust and corrode, our commitment to durability and performance ensures long-lasting, industry-leading quality.

WE BUILD TO YOUR SPECIFICATION

We craft each product to meet your exact specifications, ensuring precision and performance tailored to your needs. Our attention to detail guarantees top-tier quality, validated through NSF certification and UL listing for safety and industry standards.

CHEF COUNTERS

SINKS

WORK TABLES

DISHTABLES

WALL SHELVES

WALL MOUNTED CABINETS

ENCLOSED TABLES

BEVERAGE COUNTERS

EQUIPMENT STANDS

OVER SHELVES & POT RACKS



STAINLESS STEEL CUSTOM FABRICATION

CONTACT US FOR A QUOTE

Partner with Winholt for your next project and experience the difference of working with a trusted leader in custom stainless steel fabrication. We're committed to providing exceptional value, expert craftsmanship, and the quality your business deserves. Please reach out to your Winholt Sales Representative: email sales@winholt.com or call 800.444.3595.

CUSTOM STAINLESS STEEL FABRICATION

GENERAL NOTES

- * TOP: 18 GA. SS #3 POLISH
- * BODY: 18 GA. SS #3 POLISH
- * DOORS: SINGLE PANEL CONSTRUCTION, 18 GA. SS
- * LEGS: 1-1/2" DIA. 18 GA. SS TUBING
- * ALL SEAMS WELDED & POLISHED
- * FINISH SHALL BE NO BURNS OR SHARP EDGES
- * MEETS NSF STANDARD 2.

FEATURES

- * HIGH BACK SPLASH
- * (1) 20" X 20" X 1/4" DEEP SS SINK WITH 3-1/2" CABINET DRAIN
- * SHIP TO SUPPLY (1) SPLASH MOUNT SPRING TYPE PRE-RINSE FAUCET WITH (1) ADD-ON 1/2" SPRAY FAUCET
- * (2) 12" X 20" X 2" DEEP SS ROLLER BEARING DRAWERS
- * (8) ADJUSTABLE SS BULLET FEET, 1-1/2"

PROJ. NO.	1143574
DATE	08/11/2021
BY	WINHOLT
CHECKED	WINHOLT
APP. DATE	08/11/2021
SCALE	AS SHOWN
SHEET	1 OF 2



CUSTOMIZED STAINLESS STEEL FABRICATION, YOUR GO-TO SOURCE

GENERAL NOTES

- * TOP: 18 GA. SS #3 POL.
- * UNDER SHELF: 18 GA. SS #3 POL.
- * LEGS: 1-1/2" DIA. 18 GA. SS TUBING
- * SPREADERS: 1-1/2" DIA. SS TUBING
- * FRET CHANNELS: 18 GA. SS
- * ALL SEAMS WELDED AND POLISHED. THERE WILL BE NO BURNS OR SHARP EDGES.
- * MEETS NSF STANDARDS 2.

FEATURES

- * (1) 18" X 20" X 1/4" DEEP SS SINK WITH 1-1/2" CABINET DRAIN
- * SHIP TO SUPPLY (2) SPLASH MOUNT 1/2" SPRAY FAUCET
- * (8) ADJUSTABLE SS BULLET TYPE FEET
- * SHIP TO SUPPLY (1) SPLASH MOUNT 1/4" BURNER

PROJ. NO.	1143574
DATE	08/11/2021
BY	WINHOLT
CHECKED	WINHOLT
APP. DATE	08/11/2021
SCALE	AS SHOWN
SHEET	1 OF 2

GENERAL NOTES

- * TOP: 18 GA. SS #3 POLISH
- * SUPPORTS: 18 GA. SS
- * SPREADERS: 1-1/2" DIA. SS TUBING
- * CHANNELS: 18 GA. SS
- * LEGS: 1-1/2" DIA. SS TUBING
- * FEET: ADJUSTABLE SS BULLET TYPE
- * ALL SEAMS WELDED & POLISHED
- * MEETS NSF STD. 2.

FEATURES

- * 6" BACK SPLASH
- * MARINE EDGE
- * (1) 20" X 20" X 1/4" DEEP TUB WITH ROTARY WASTE LEVER DRAIN AND BRACKETS AND PRE-RINSE BASKET
- * (2) 1/2" DUPLEX OUTLET
- * SHIPS IN 2 PIECES - TO BE WELDED TOGETHER IN FIELD

PROJ. NO.	1154598
DATE	08/11/2021
BY	WINHOLT
CHECKED	WINHOLT
APP. DATE	08/11/2021
SCALE	AS SHOWN
SHEET	1 OF 2

GENERAL NOTES

- * TOP: 18 GA. SS #3 POLISH
- * SUPPORTS: 18 GA. SS
- * LEGS AND SPREADERS: 1-1/2" DIA. SS TUBING
- * FRET CHANNELS: 18 GA. SS
- * FEET - ADJUSTABLE SS BULLET TYPE
- * ALL SEAMS WELDED & POLISHED
- * FINISH SHALL BE NO BURNS OR SHARP EDGES
- * MEETS NSF STD. 2.

FEATURES

- * 6" BACK SPLASH
- * (2) 18" X 20" X 1/4" DEEP SS SINKS WITH ROTARY WASTE LEVER DRAIN AND BRACKETTE
- * SHIP TO SUPPLY (2) SPLASH MOUNT 1/2" SPRAY FAUCETS
- * (1) LEFT UNDER-SHELF
- * (8) 1/2" BRACKETS FOR WALL MOUNTING

PROJ. NO.	1151075
DATE	08/11/2021
BY	WINHOLT
CHECKED	WINHOLT
APP. DATE	08/11/2021
SCALE	AS SHOWN
SHEET	1 OF 2

STAINLESS STEEL SINKS

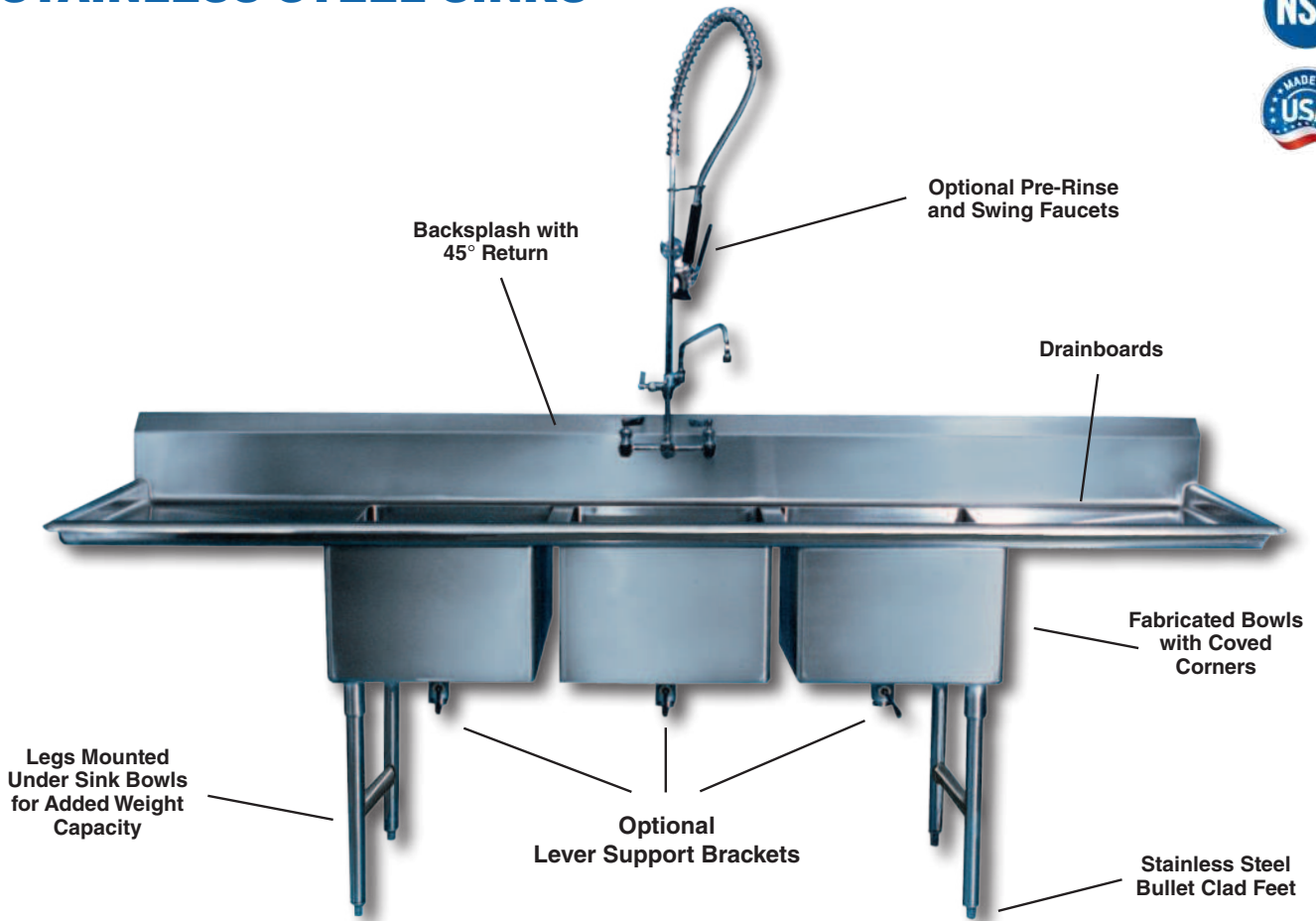

16 Gauge Stainless Steel Sinks - Model Number Chart			
Model Number: WS3T20202D18			
# of Sink Compartments	Tub Size	# of Drainboards	Drainboard Size
WS3T <i>3 Tub Sink</i>	2020 <i>20"L x 20"W Tub Size</i>	2D <i>2 Drainboards</i>	18 <i>18" Drainboards</i>
3 Compartments, 12" Deep, 2 Drainboards, 16 Gauge			

14 Gauge Stainless Steel Sinks - Model Number Chart					
Model Number: WS3T20202D18-14DP-14GA					
# of Sink Compartments	Tub Size	# of Drainboards	Drainboard Size	Tub Depth	Gauge
WS3T <i>3 Tub Sink</i>	2020 <i>20"L x 20"W Tub Size</i>	2D <i>2 Drainboards</i>	18 <i>18" Drainboards</i>	-14DP <i>14"D Tub Size</i>	-14GA <i>14 Gauge Stainless Steel</i>
3 Compartments, 14" Deep, 2 Drainboards, 14 Gauge					

As part of our commitment to continuous product improvement, Winholt reserves the right to modify materials and specifications without prior notice.

800.444.3595 | orders@winholt.com | www.winholt.com



- All welded construction
- Complies with all sanitary standards: 16 GA or 14 GA 300 series stainless steel
- 12" or 14" deep fabricated bowls with covered corners
- Cross bracing for heavy duty support and stability
- Equipped with stainless steel gussets, stainless steel legs and stainless steel clad adjustable feet for leveling
- 9" backsplash with 45° return

STAINLESS SINKS - 1 COMPARTMENT WITHOUT DRAINBOARD

Bowl Size (in)	L x W x H (in)	16 Gauge 12" Water Level	Wt (lb)	14 Gauge 14" Water Level	Wt (lb)
16x18	21x23½x34	WS1T1618	45	WS1T1618-14DP-14GA	50
18x18	23x23½x34	WS1T1818	45	WS1T1818-14DP-14GA	50
16x20	21x25½x34	WS1T1620	43	WS1T1620-14DP-14GA	55
20x20	25x25½x34	WS1T2020	55	WS1T2020-14DP-14GA	60
18x24	23x29½x34	WS1T1824	53	WS1T1824-14DP-14GA	59
24x24	29x29½x34	WS1T2424	62	WS1T2424-14DP-14GA	68
20x28	25x33½x34	WS1T2028	65	WS1T2028-14DP-14GA	72

OPTIONS: WB18 18" WALL BRACKETS

Freight Class: 200



WS1T2020



WS1T2424D24

Shown with Lever
Support Bracket

Sink Hardware
Sold Separately

STAINLESS SINKS - 1 COMPARTMENT WITH 2 DRAINBOARDS

Bowl Size (in)	L x W x H (in)	Drbd Size (in)	16 Gauge 12" Water Level	Wt (lb)	14 Gauge 14" Water Level	Wt (lb)
16x18	52x23½x34	18	WS1T16182D18	62	WS1T16182D18-14DP-14GA	68
	64x23½x34	24	WS1T16182D24	69	WS1T16182D24-14DP-14GA	77
18x18	54x23½x34	18	WS1T18182D18	71	WS1T18182D18-14DP-14GA	76
	66x23½x34	24	WS1T18182D24	80	WS1T18182D24-14DP-14GA	87
16x20	52x25½x34	18	WS1T16202D18	66	WS1T16202D18-14DP-14GA	70
	64x25½x34	24	WS1T16202D24	74	WS1T16202D24-14DP-14GA	80
20x20	40x25½x34	18	WS1T20202D18	85	WS1T20202D18-14DP-14GA	90
	44x25½x34	24	WS1T20202D24	95	WS1T20202D24-14DP-14GA	101
18x24	54x29½x34	18	WS1T18242D18	75	WS1T18242D18-14DP-14GA	80
	66x29½x34	24	WS1T18242D24	83	WS1T18242D24-14DP-14GA	91
24x24	60x29½x34	18	WS1T24242D18	92	WS1T24242D18-14DP-14GA	95
	72x29½x34	24	WS1T24242D24	112	WS1T24242D24-14DP-14GA	103
20x28	40x33½x34	18	WS1T20282D18	102	WS1T20282D18-14DP-14GA	115
	44x33½x34	24	WS1T2028-2D24	125	WS1T20282D24-14DP-14GA	126

OPTIONS: WB18 18" WALL BRACKETS

Freight Class: 200

800.444.3595 | sales@winholt.com | www.winholt.com





WS1T1824LD24

Customize to meet your requirements:

- Stainless Sink Single Compartment with Drainboard
- 14" Swing Faucet Splash Mount
- Rotary Lever Waste Valve with Flat Strainer
- Flange Feet
- All welded construction
- Complies with all sanitary standards: 16 GA or 14 GA 300 series stainless steel
- 12" or 14" deep fabricated bowls with covered corners
- Cross bracing for heavy duty support and stability
- Equipped with stainless steel gussets, stainless steel legs and stainless steel clad adjustable feet for leveling
- 9" backsplash with 45° return



**STAINLESS SINKS
1 COMPARTMENT
WITH 1 DRAINBOARD**

Bowl Size (in)	L x W x H (in)	Drbd Size (in)	Drbd Left / Right	16 Gauge 12" Water Level	Wt (lb)	14 Gauge 14" Water Level	Wt (lb)
16x18	36½x23½x34	18	LEFT	WS1T1618LD18	53	WS1T1618LD18-14DP-14GA	56
			RIGHT	WS1T1618RD18		WS1T1618RD18-14DP-14GA	
	42½x23½x34	24	LEFT	WS1T1618LD24	57	WS1T1618LD24-14DP-14GA	60
			RIGHT	WS1T1618RD24		WS1T1618RD24-14DP-14GA	
18x18	38½x23½x34	18	LEFT	WS1T1818LD18	55	WS1T1818LD18-14DP-14GA	59
			RIGHT	WS1T1818RD18		WS1T1818RD18-14DP-14GA	
	44½x23½x34	24	LEFT	WS1T1818LD24	58	WS1T1818LD24-14DP-14GA	63
			RIGHT	WS1T1818RD24		WS1T1818RD24-14DP-14GA	
16x20	36½x25½x34	18	LEFT	WS1T1620LD18	54	WS1T1620LD18-14DP-14GA	58
			RIGHT	WS1T1620RD18		WS1T1620RD18-14DP-14GA	
	42½x25½x34	24	LEFT	WS1T1620LD24	57	WS1T1620LD24-14DP-14GA	62
			RIGHT	WS1T1620RD24		WS1T1620RD24-14DP-14GA	
20x20	40½x25½x34	18	LEFT	WS1T2020LD18	70	WS1T2020LD18-14DP-14GA	77
			RIGHT	WS1T2020RD18		WS1T2020RD18-14DP-14GA	
	46½x25½x34	24	LEFT	WS1T2020LD24	74	WS1T2020LD24-14DP-14GA	83
			RIGHT	WS1T2020RD24		WS1T2020RD24-14DP-14GA	
18x24	38½x29½x34	18	LEFT	WS1T1824LD18	64	WS1T1824LD18-14DP-14GA	70
			RIGHT	WS1T1824RD18		WS1T1824RD18-14DP-14GA	
	44½x29½x34	24	LEFT	WS1T1824LD24	68	WS1T1824LD24-14DP-14GA	75
			RIGHT	WS1T1824RD24		WS1T1824RD24-14DP-14GA	
24x24	50½x29½x34	24	LEFT	WS1T2424LD24	77	WS1T2424LD24-14DP-14GA	85
			RIGHT	WS1T2424RD24		WS1T2424RD24-14DP-14GA	
20x28	40½x33½x34	18	LEFT	WS1T2028LD18	87	WS1T2028LD18-14DP-14GA	97
			RIGHT	WS1T2028RD18		WS1T2028RD18-14DP-14GA	
	46½x33½x34	24	LEFT	WS1T2028LD24	88	WS1T2028LD24-14DP-14GA	101
			RIGHT	WS1T2028RD24		WS1T2028RD24-14DP-14GA	

OPTIONS: WB18 18" WALL BRACKETS

Freight Class: 200

STAINLESS SINKS - 2 COMPARTMENT WITHOUT DRAINBOARD



Bowl Size (in)	L x W x H (in)	16 Gauge 12" Water Level	Wt (lb)	14 Gauge 14" Water Level	Wt (lb)
16x18	39x23½x34	WS2T1618	74	WS2T1618-14DP-14GA	79
18x18	43x23½x34	WS2T1818	78	WS2T1818-14DP-14GA	85
16x20	39x25½x34	WS2T1620	76	WS2T1620-14DP-14GA	83
20x20	47x25½x34	WS2T2020	96	WS2T2020-14DP-14GA	110
18x24	43x29½x34	WS2T1824	92	WS2T1824-14DP-14GA	103
24x24	55x29½x34	WS2T2424	109	WS2T2424-14DP-14GA	124
20x28	47x33½x34	WS2T2028	115	WS2T2028-14DP-14GA	134



WS1T1824LD24

OPTIONS: WB18 18" WALL BRACKETS
Freight Class: 200

WS2T1824D24



STAINLESS SINKS - 2 COMPARTMENT WITH 2 DRAINBOARDS

Bowl Size (in)	L x W x H (in)	Drbd Size (in)	16 Gauge 12" Water Level	Wt (lb)	14 Gauge 14" Water Level	Wt (lb)
16x18	70x23½x34	18	WS2T16182D18	83	WS2T16182D18-14DP-14GA	90
	82x23½x34	24	WS2T16182D24	86	WS2T16182D24-14DP-14GA	95
18x18	74x23½x34	18	WS2T18182D18	96	WS2T18182D18-14DP-14GA	106
	86x23½x34	24	WS2T18182D24	103	WS2T18182D24-14DP-14GA	115
16x20	70x25½x34	18	WS2T16202D18	94	WS2T16202D18-14DP-14GA	103
	82x25½x34	24	WS2T16202D24	101	WS2T16202D24-14DP-14GA	112
20x20	78x25½x34	18	WS2T20202D18	135	WS2T20202D18-14DP-14GA	150
	90x25½x34	24	WS2T20202D24	150	WS2T20202D24-14DP-14GA	159
18x24	74x29½x34	18	WS2T18242D18	113	WS2T18242D18-14DP-14GA	130
	86x29½x34	24	WS2T18242D24	122	WS2T18242D24-14DP-14GA	139
24x24	86x29½x34	18	WS2T24242D18	128	WS2T24242D18-14DP-14GA	155
	98x29½x34	24	WS2T24242D24	139	WS2T24242D24-14DP-14GA	160
20x28	82x35½x34	18	WS2T20282D18	159	WS2T20282D18-14DP-14GA	175
	90x35½x34	24	WS2T20282D24	170	WS2T20282D24-14DP-14GA	185

Sink Hardware Sold Separately

OPTIONS: WB18 18" WALL BRACKETS
Freight Class: 200

WS2TS2424LD24



Sink Hardware Sold Separately

STAINLESS SINKS - 2 COMPARTMENT WITH 1 DRAINBOARD

Bowl Size (in)	L x W x H (in)	Drbd Size (in)	Drbd Left / Right	16 Gauge 12" Water Level	Wt (lb)	14 Gauge 14" Water Level	Wt (lb)
16x18	54½x23½x34	18	LEFT	WS2T1618LD18	83	WS2T1618LD18-14DP-14GA	90
			RIGHT	WS2T1618RD18		WS2T1618RD18-14DP-14GA	
	60½x23½x34	24	LEFT	WS2T1618LD24	86	WS2T1618LD24-14DP-14GA	95
			RIGHT	WS2T1618RD24		WS2T1618RD24-14DP-14GA	
18x18	58½x23½x34	18	LEFT	WS2T1818LD18	87	WS2T1818LD18-14DP-14GA	95
			RIGHT	WS2T1818RD18		WS2T1818RD18-14DP-14GA	
	64½x23½x34	24	LEFT	WS2T1818LD24	90	WS2T1818LD24-14DP-14GA	100
			RIGHT	WS2T1818RD24		WS2T1818RD24-14DP-14GA	
16x20	54½x25½x34	18	LEFT	WS2T1620LD18	85	WS2T1620LD18-14DP-14GA	93
			RIGHT	WS2T1620RD18		WS2T1620RD18-14DP-14GA	
	60½x25½x34	24	LEFT	WS2T1620LD24	88	WS2T1620LD24-14DP-14GA	98
			RIGHT	WS2T1620RD24		WS2T1620RD24-14DP-14GA	
20x20	62½x25½x34	18	LEFT	WS2T2020LD18	117	WS2T2020LD18-14DP-14GA	133
			RIGHT	WS2T2020RD18		WS2T2020RD18-14DP-14GA	
	68½x25½x34	24	LEFT	WS2T2020LD24	122	WS2T2020LD24-14DP-14GA	142
			RIGHT	WS2T2020RD24		WS2T2020RD24-14DP-14GA	
18x24	58½x29½x34	18	LEFT	WS2T1824LD18	107	WS2T1824LD18-14DP-14GA	120
			RIGHT	WS2T1824RD18		WS2T1824RD18-14DP-14GA	
	64½x29½x34	24	LEFT	WS2T1824LD24	111	WS2T1824LD24-14DP-14GA	126
			RIGHT	WS2T1824RD24		WS2T1824RD24-14DP-14GA	
24x24	76½x29½x34	24	LEFT	WS2T2424LD24	127	WS2T2424LD24-14DP-14GA	146
			RIGHT	WS2T2424RD24		WS2T2424RD24-14DP-14GA	
20x28	62½x33½x34	18	LEFT	WS2T2028LD18	175	WS2T2028LD18-14DP-14GA	190
			RIGHT	WS2T2028RD18		WS2T2028RD18-14DP-14GA	
	68½x33½x34	24	LEFT	WS2T2028LD24	185	WS2T2028LD24-14DP-14GA	199
			RIGHT	WS2T2028RD24		WS2T2028RD24-14DP-14GA	

OPTIONS: WB18 18" WALL BRACKETS
Freight Class: 200

STAINLESS SINKS - 3 COMPARTMENT WITHOUT DRAINBOARD

Bowl Size (in)	L x W x H (in)	16 Gauge 12" Water Level	Wt (lb)	14 Gauge 14" Water Level	Wt (lb)
16x18	57x23½x34	WS3T1618	40	WS3T1618-14DP-14GA	44
18x18	63x23½x34	WS3T1818	109	WS3T1818-14DP-14GA	124
16x20	57x25½x34	WS3T1620	107	WS3T1620-14DP-14GA	119
20x20	69x25½x34	WS3T2020	142	WS3T2020-14DP-14GA	165
18x24	63x29½x34	WS3T1824	131	WS3T1824-14DP-14GA	150
24x24	81x29½x34	WS3T2424	157	WS3T2424-14DP-14GA	182
20x28	69x33½x34	WS3T2028	170	WS3T2028-14DP-14GA	200

OPTIONS: WB18 18" WALL BRACKETS
Freight Class: 200



WS3T1818



WS3T18242D18

STAINLESS SINKS - 3 COMPARTMENT WITH 2 DRAINBOARDS

Bowl Size (in)	L x W x H (in)	Drbd Size (in)	16 Gauge 12" Water Level	Wt (lb)	14 Gauge 14" Water Level	Wt (lb)
16x18	88x23½x34	18	WS3T16182D18	121	WS3T16182D18-14DP-14GA	139
	100x23½x34	24	WS3T16182D24	128	WS3T16182D24-14DP-14GA	147
18x18	94x23½x34	18	WS3T18182D18	127	WS3T18182D18-14DP-14GA	146
	106x23½x34	24	WS3T18182D24	134	WS3T18182D24-14DP-14GA	155
16x20	88x25½x34	18	WS3T16202D18	125	WS3T16202D18-14DP-14GA	142
	100x25½x34	24	WS3T16202D24	132	WS3T16202D24-14DP-14GA	151
20x20	100x25½x34	18	WS3T20202D18	180	WS3T20202D18-14DP-14GA	204
	112x25½x34	24	WS3T20202D24	191	WS3T20202D24-14DP-14GA	220
18x24	94x29½x34	18	WS3T18242D18	172	WS3T18242D18-14DP-14GA	196
	106x29½x34	24	WS3T18242D24	180	WS3T18242D24-14DP-14GA	207
24x24	112x29½x34	18	WS3T24242D18	190	WS3T24242D18-14DP-14GA	229
	124x29½x34	24	WS3T24242D24	206	WS3T24242D24-14DP-14GA	239
20x28	102x33½x34	18	WS3T20282D18	62	WS3T20282D18-14DP-14GA	219
	112x33½x34	24	WS3T20282D24	65	WS3T20282D24-14DP-14GA	229

OPTIONS: WB18 18" WALL BRACKETS
Freight Class: 200

As part of our commitment to continuous product improvement, Winholt reserves the right to modify materials and specifications without prior notice.

800.444.3595 | sales@winholt.com | www.winholt.com





WS3T1824LD18



STAINLESS SINKS 3 COMPARTMENT WITH 1 DRAINBOARD

Bowl Size (in)	L x W x H (in)	Drbd Size (in)	Drbd Left / Right	16 Gauge 12" Water Level	Wt (lb)	14 Gauge 14" Water Level	Wt (lb)
16x18	72½x23½x34	18	LEFT	WS3T1618LD18	112	WS3T1618LD18-14DP-14GA	127
			RIGHT	WS3T1618RD18		WS3T1618RD18-14DP-14GA	
	78½x23½x34	24	LEFT	WS3T1618LD24	116	WS3T1618LD24-14DP-14GA	132
			RIGHT	WS3T1618RD24		WS3T1618RD24-14DP-14GA	
18x18	78½x23½x34	18	LEFT	WS3T1818LD18	118	WS3T1818LD18-14DP-14GA	135
			RIGHT	WS3T1818RD18		WS3T1818RD18-14DP-14GA	
	84½x23½x34	24	LEFT	WS3T1818LD24	122	WS3T1818LD24-14DP-14GA	139
			RIGHT	WS3T1818RD24		WS3T1818RD24-14DP-14GA	
16x20	72½x25½x34	18	LEFT	WS3T1620LD18	115	WS3T1620LD18-14DP-14GA	120
			RIGHT	WS3T1620RD18		WS3T1620RD18-14DP-14GA	
	78½x25½x34	24	LEFT	WS3T1620LD24	119	WS3T1620LD24-14DP-14GA	129
			RIGHT	WS3T1620RD24		WS3T1620RD24-14DP-14GA	
20x20	84½x25½x34	18	LEFT	WS3T2020LD18	165	WS3T2020LD18-14DP-14GA	185
			RIGHT	WS3T2020RD18		WS3T2020RD18-14DP-14GA	
	90½x25½x34	24	LEFT	WS3T2020LD24	170	WS3T2020LD24-14DP-14GA	200
			RIGHT	WS3T2020RD24		WS3T2020RD24-14DP-14GA	
18x24	78½x29½x34	18	LEFT	WS3T1824LD18	141	WS3T1824LD18-14DP-14GA	163
			RIGHT	WS3T1824RD18		WS3T1824RD18-14DP-14GA	
	84½x29½x34	24	LEFT	WS3T1824LD24	145	WS3T1824LD24-14DP-14GA	169
			RIGHT	WS3T1824RD24		WS3T1824RD24-14DP-14GA	
24x24	102½x29½x34	24	LEFT	WS3T2424LD24	171	WS3T2424LD24-14DP-14GA	201
			RIGHT	WS3T2424RD24		WS3T2424RD24-14DP-14GA	
20x28	84½x33½x34	18	LEFT	WS3T2028LD18	185	WS3T2028LD18-14DP-14GA	215
			RIGHT	WS3T2028RD18		WS3T2028RD18-14DP-14GA	
	90½x33½x34	24	LEFT	WS3T2028LD24	195	WS3T2028LD24-14DP-14GA	225
			RIGHT	WS3T2028RD24		WS3T2028RD24-14DP-14GA	

OPTIONS: WB18 18" WALL BRACKETS
Freight Class: 200

STAINLESS SINKS - 3 COMPARTMENT MEAT & PLATTER, BAKERY & DELI, CONVENIENCE



WS3T18242D24-SS
Space Saver Design shown
with lever support brackets

Sink Hardware Sold
Separately

Stainless Meat Platter Sink 3 Compartment					
Bowl Size (in)	LxW x H (in)	Drainboard Size (in)	Drainboard	16 Gauge 12" Water Level	Wt (lb)
15x32	69½x37½x34	18	LEFT	WS3T1532LD18	183
15x32	69½x37½x34	18	RIGHT	WS3T1532RD18	183
15x32	69½x37½x34	18	LEFT & RIGHT	WS3T15322D18	183
Stainless Bakery & Deli Sink 3 Compartment					
19x28	66x33x34			WS3T1928	175
19x28	82½x33x34	18	LEFT	WS3T1928LD18	189
19x28	82½x33x34	18	RIGHT	WS3T1928RD18	189
19x28	99x33x34	18	LEFT & RIGHT	WS3T19282D18	199
Stainless Convenience Sink 3 Compartment					
10x14	58½x19½x34	12	LEFT & RIGHT	WS3T10142D12	85
10x14	70½x19½x34	18	LEFT & RIGHT	WS3T10142D18	120
14x16	70½x21½x34	12	LEFT & RIGHT	WS3T14162D12	138

OPTIONS: WB18 18" WALL BRACKETS
Freight Class: 200

SINK MODIFICATIONS



MODEL	DESCRIPTION	SOLD BY	MODEL	DESCRIPTION	SOLD BY
Top Modifications			Drainboard Modifications		
WH-ASBH	Anti. Siphon Vacuum Breaker Holes	each	WH-EXDB	Extra Drainboard	per lin. ft.
WH-WFJ	Welded Field Joint (<i>by other</i>)	each	WH-DBCTN	Corner Turn for Drainboard	each
WH-DSCB	Installation of Disposal Cone with 6" x 9" control bracket, faucet holes <i>(Cone supplied by other)</i>	each	WH-USDB	Undershelf Drainboard	per lin. ft.
WH-DSCB14	Installation of Disposal Cone with 14" x 16" control bracket, faucet holes <i>(Cone supplied by other)</i>	each	Additional Crating Costs		
WH-WATRG	Waste trough with removable basket - 2" deep	each	WH-CRATE	Complete Crating	per sink
WH-COLLAR	Installation of collar with each 6" x 9" control bracket <i>(Collar supplied by other)</i>	each	WH-EXPCRATE	Export Crating	per sink
WH-COLLAR14	Installation of Collar with 14" x 16" control bracket <i>(Collar supplied by other)</i>	each	Stainless Steel Sink Cover for Sink Bowls		
WH-DMFH	Deck Mounted Holes, per faucet	each	WSA-SSC1014	S/S Sink Cover, 14"L x 10"W bowl	each
WH-SPFH	Splash Mounted Holes, per faucet	each	WSA-SSC1416	S/S Sink Cover, 16"L x 14"W bowl	each
Base Modifications			WSA-SSC1618	S/S Sink Cover, 18"L x 16"W bowl	each
WH-HFLEG	H-Frame Support Leg	each	WSA-SSC1818	S/S Sink Cover, 18"L x 18"W bowl	each
WH-CBH	Holder for Cutting Board / Sink Cover	each	WSA-SSC1620	S/S Sink Cover, 20"L x 16"W bowl	each
WS-SDDEAD	Sound Deadening Spray	per lin. ft.	WSA-SSC2020	S/S Sink Cover, 20"L x 20"W bowl	each
WH-WHCG	Work Height Change	each	WSA-SSC1824	S/S Sink Cover, 24"L x 18"W bowl	each
Backsplash & Sidesplash Modifications			WSA-SSC2424	S/S Sink Cover, 24"L x 24"W bowl	each
WH-SPCU	Splash cutout	each	WSA-SSC1928	S/S Sink Cover, 28"L x 19"W bowl	each
WH-BS13	Backsplash up to 13"	per lin. ft.	WSA-SSC2028	S/S Sink Cover, 28"L x 20"W bowl	each
WH-BS18	Backsplash up to 18"	per lin. ft.	WSA-SSC1532	S/S Sink Cover, 32"L x 15"W bowl	each
WH-SSP	Sink Sidesplash	each	Poly Top Sink Cover for Sink Bowls		
WH-SSI	Integrated Sidesplash	per lin. ft.	WSA-PSC1618	Poly Sink Cover, 18"L x 16"W bowl	each
Sink Bowl Modifications			WSA-PSC1818	Poly Sink Cover, 18"L x 18"W bowl	each
WS-SSKRT	Sink Skirt	each	WSA-PSC1620	Poly Sink Cover, 20"L x 16"W bowl	each
WS-RLWV-BRKT	Rotary Leverwaste Support Bracket	each	WSA-PSC2020	Poly Sink Cover, 20"L x 20"W bowl	each
WHS-RLWV-OF	Punch for overflow hole in rear of sink	each	WSA-PSC-1824	Poly Sink Cover, 24"L x 18"W bowl	each
WH-WS-RLWV-ST	Leverwaste Support Bracket	each	WSA-PSC2424	Poly Sink Cover, 24"L x 24"W bowl	each
WH-WS-RLWV-OF	Lever Waste Drain w/ Overflow	each	WSA-PSC1928	Poly Sink Cover, 28"L x 19"W bowl	each
WH-CT12XXXX	Custom Bowl 12" deep	each	WSA-PSC2028	Poly Sink Cover, 28"L x 20"W bowl	each
WH-CT14XXXX	Custom Bowl 14" deep	each	WSA-PSC1532	Poly Sink Cover, 32"L x 15"W bowl	each
WH-CT16XXXX	Custom Bowl 16" deep	each	Leg Accessories		
WH-CTMOD	Modify Bowl Depth	each	4497-3	Flanged stainless steel bullet foot	each
			4471	Stainless steel bullet clad foot	each
			WH-LWB	Leg to wall brace	each
			RECESSED LEG 6	6" Recessed Leg	each

HAND SINKS



HAND SINK, WALL MOUNT WITH ELECTRIC EYE ACTIVATED FAUCET

- High quality 16 gauge stainless steel
- 5" deep bowl
- Faucet, basket drain and soap dispenser are all included.
- Standard with electric eye activated faucet

Bowl Size (in)	L x W (in)	Model Number	Wt (lb)
10x14x5	18x15	WS-HS-1410-EF	15



WS-HS-1410-EF

HAND SINK, WALL MOUNT WITH SIDESPLASH & KNEE VALVE

- High quality 20 gauge stainless steel
- 9½" Backsplash and (2) sidesplashes
- 5" deep bowl
- 4" Gooseneck faucet, basket drain and knee valve controls are all included.

Bowl Size (in)	L x W (in)	Model Number	Wt (lb)
10x14x5	17x15	WS-HS-1410KV-2SS-KT	15



WS-HS-1410KV-2SS-KT



HAND SINK, WALL MOUNT WITH HAND VALVES

- High quality 16 gauge stainless steel
- 6" deep bowl
- Gooseneck faucet, basket drain and soap dispenser are all included.

Bowl Size (in)	L x W (in)	Model Number	Wt (lb)
10x14x6	18x15	WHWS1410HV	45



WHWS1410HV

HAND SINK, WALL MOUNT WITH KNEE VALVES

- High quality 16 gauge stainless steel
- 6" deep bowl
- Gooseneck faucet, basket drain and soap dispenser are all included.

Bowl Size (in)	L x W (in)	Model Number	Wt (lb)
10x14x6	18x15	WWHS1410SP	45

WWHS1410SP



All Freight Class: 150

As part of our commitment to continuous product improvement, Winholt reserves the right to modify materials and specifications without prior notice.

HAND SINKS



WS-HS-1410-5-F



WS-HS-1410-5-2SS

Welded Sidesplashes for Hand Sinks

Left Sidesplash: LSP
 Right Sidesplash: RSP
 Left & Right Sidesplash: 2SS



WHPS1110



WHPS1616-KT

ECONOMY HAND SINK, WALL MOUNT



- High quality 20 gauge stainless steel
- Bowl is 5" deep
- Backsplash is 9½"
- 4" Gooseneck faucet, 1½" basket drain.

Bowl Size (in)	L x W (in)	Model Number	Wt (lb)
10x14x5	17x15	WS-HS-1410-5-F	15

Freight Class: 150

HAND SINK, WALL MOUNT WITH SIDESPLASHES

- High quality 20 gauge stainless steel
- Bowl is 5" deep
- Backsplash is 9½"
- 4" Gooseneck faucet, 1½" basket drain
- Welded sidesplashes

Bowl Size (in)	L x W (in)	Model Number	Wt (lb)
10x14x5	17x15	WS-HS-1410-5-2SS	15

Freight Class: 150

PEDESTAL HAND SINK - 1 PEDAL

- High quality 16 gauge stainless steel
- Foot pedals for hands-free control to lessen contamination.
- Gooseneck faucet, basket drain and soap dispenser are all included.
- 18" high backsplash

Bowl Size (in)	L x W (in)	Model Number	Wt (lb)
11x10x8	12x11	WHPS1110	50

Freight Class: 150

PEDESTAL HAND SINK - 2 PEDALS

- High quality 16 gauge stainless steel
- Foot Pedals for hands-free control to lessen contamination
- Gooseneck faucet, basket drain and soap dispenser are all included
- 7¾" backsplash

Bowl Size (in)	L x W x H (in)	Model Number	Wt (lb)
16x16x10	18x18x42	WHPS1616-KT	50

Freight Class: 150

MOP SINK CABINETS

- Sanitary solution for keeping your cleaning station contained and cleaning supplies stored.
- All welded stainless steel design with shelves for storage, hinged doors, a 15° slanted top and vents on the back/sides of unit.
- Mop tub dimensions: 16"W x 20"L x 12"D 3.5". Tub has a 3.5" recessed basket drain.
- Single Cabinet has field reversible door

Model Number	Order #	Overall Dimensions			Approx. Ship Wt
		Width	Length	Height	
		(in)	(in)	(in)	
Two Doors					
Sink on Right Side					
STCT-HD2450.5H84-MPS-ST-KT	1151489	24	50½	84	120
Sink on Left Side					
STCT-HD2450.5H84-MPSL-ST-KT	1151974	24	50½	84	120
One Door					
STCT-HD2425H84-MPS-ST-KT	1151471	24	25½	84	120

Freight Class: 175

STCT-HD2450.5H84-MPS-ST-KT



STCT-HD2425H84-MPS-ST-KT



MS1620-DP12-KT

MOP SINKS

- High quality 16 gauge stainless steel
- 2" backsplash standard
- 3½" basket drain

Bowl Size WxLxH (in)	L x W (in)	Model Number	Wt (lb)
16x20x6	21x25	MS-1620-DP6-KT	26
16x20x12	20x24	MS-1620-DP12-KT	45
24x24x8	28x28	MS-2424-DP8-KT	55

Freight Class: 150

Mop Sink Flashings Options:

Specify options by adding suffix to model numbers

LFL	Left flashing
RFL	Right flashing
2FL	Left & Right flashing
BFL	Back flashing
FL-SFHOLE	Service faucet hole
FL-CSSRL	Coved seam sealers for right, left or both flashings
FL-CSSB	Coved seam sealers for back flashing

TROUGH SINKS

- Efficient multi-user solution for high-traffic handwashing and utility areas in commercial kitchens and backrooms.
- All welded 16 gauge stainless steel construction with integrated 10" backsplash and faucet cutouts.
- Tub dimensions: 14"W x 12"D. Basin includes a 3½" center drain with removable strainer basket.
- (2) Z clips included for wall-mount
- Adjustable bullet clad feet

Model Number	Order #	Bowl Size L x W (in)	Overall Dimensions			Approx. Ship Wt
			Width	Length	Height	
			(in)	(in)	(in)	
WS1T3314DP12-KT	1154071	33x14	17 ³ / ₈	36	49	132
WS1T4514DP12-KT	1154078	45x14	17 ³ / ₈	48	49	183
WS1T5714DP12-KT	1154080	57x14	17 ³ / ₈	60	49	195
WS1T6914DP12-KT	1154082	69x14	17 ³ / ₈	72	49	226

Freight Class: 150



WS1T5714DP12-KT



WS-DIS-FE-1620-12DP



WS-DIS-FE-1110-6DP



WS-DISME1109



WS2T-DISME-1614-10DP

1 COMPARTMENT SELF RIM DROP IN SINK

- High quality 16 gauge stainless steel

Bowl Size WxLxD (in)	WxL (in)	Model Number	Wt (lb)
9x9x3	13x16	WS-DIS-FE-99-3DP	16
10x11x6	13x16	WS-DIS-FE-1110-6DP	16
10x11x10	13x16	WS-DIS-FE-1110-10DP	18
10x14x6	13x19	WS-DIS-FE-1410-6DP	17
10x14x10	13x19	WS-DIS-FE-1410-10DP	19
14x10x6	17x15	WS-DIS-FE-1014-6DP	15
16x14x8	19x19	WS-DIS-FE-1416-8DP	25
20x16x8	32x21	WS-DIS-FE-1620-8DP	25
20x16x12	23x21	WS-DIS-FE-1620-12DP	30
28x20x12	31x25	WS-DIS-FE-2028-12DP	52

1, 2 & 3 COMPARTMENT NO DRIP MARINE EDGE DROP IN SINKS

- High quality 16 gauge stainless steel
- No drip edge standard

# of Compartments	Bowl Size WxLxD (in)	LxW (in)	Model Number	Wt (lb)
1	10x9½x10	14x15½	WS-DIS-ME-109.5	26
1	19x10x8	14x16	WS-DIS-ME-1010DP8	28
1	11x9x15	15x15	WS-DIS-ME-1109	28
1	11x14x6½	15x20	WS-DIS-ME-1114	32
1	21x15¾x12	25x22	WS-DIS-ME-1621DP12	40
1	21x15¾x14	25x22	WS-DIS-ME-1621DP14	42
2	10x14x10	25½x19	WS2T-DIS-ME-1410-10DP	34
2	14x16x10	33½x21	WS2T-DIS-ME-1614-10DP	39
2	14x16x12	33½x21	WS2T-DIS-ME-1614-12DP	47
2	20x16x8	45½x21	WS2T-DIS-ME-1620-8DP	50
2	20x16x10	45½x21	WS2T-DIS-ME-1620-10DP	52
2	20x16x12	45½x21	WS2T-DIS-ME-1620-12DP	54
3	10x14x10	38x19	WS3T-DIS-ME-1410-10DP	44
3	16x14x10	50x21	WS3T-DIS-ME-1416-10DP	48
3	16x20x12	56x25	WS3T-DIS-ME-2016-12DP	70

All Freight Class: 150

800.444.3595 | orders@winholt.com | www.winholt.com

DISHTABLES

- 4 Styles of Tables Available: Straight, Corner, Island, and Landing Ledge
- Constructed of 16 GA or 14 GA 300 series stainless
- Right to Left (R) connects to right side of machine.
- Left to Right (L) connects to left side of machine.
- Soiled table has a 20" x 20" x 8"D pre-rinse bowl to accept 3½" drain basket
- Backsplash punched to accept faucets on 8" centers
- Backsplash is 9" high, with 2" 45° return to wall
- 37" to top of rolled rim
- Optional Pre-Rinse and Splash Mount Faucet
- **Custom Sizes Available**

16 Gauge, 300 series stainless steel dishtables and legs with stainless steel clad bullet feet. Fabricated bowls are 12" deep water level.

14 Gauge, 300 series stainless steel dishtables and legs with stainless steel clad bullet feet. Fabricated bowls are 14" deep water level.

All Freight Class: 150



Optional Pre-Rinse & Splash Mount Faucets



Stainless Steel Dishtables - Model Number Chart				
Model Number: CDT-14-S-36-R				
Clean or Soiled Dishtable	Gauge	Type of Table	Length	Dishwasher Connection
CDT <i>Clean Dishtable</i>	-14 <i>14 Gauge</i>	-S <i>Straight</i> <i>(C) Corner</i> <i>(I) Island</i> <i>(L) Landed</i>	-36 <i>36"L</i>	-R <i>Connects to Right Side of Machine</i>
Clean Dishtable, 14 Gauge, 36" Straight Design, Connect to Right Side of Washer				

As part of our commitment to continuous product improvement, Winholt reserves the right to modify materials and specifications without prior notice.

DISH TABLES



SDT-16-S-36-R



Sink Hardware Sold Separately

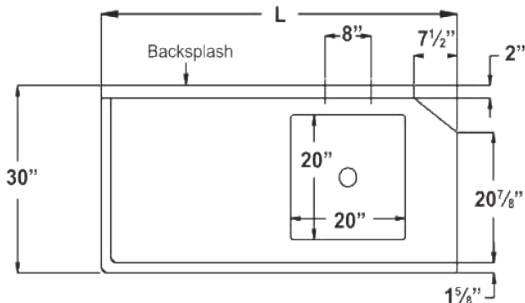

- Stainless Steel Dishtables
- Constructed of 16 GA or 14 GA 300 series stainless
- Right to Left (R) connects to right side of machine.
- Left to Right (L) connects to left side of machine.
- Soiled table has a 20" x 20" x 8"D pre-rinse bowl to accept 3 1/2" drain basket
- Backsplash punched to accept faucets on 8" centers
- Backsplash is 9" high, with 2" 45° return to wall
- 37" to top of rolled rim
- Optional Pre-Rinse and Splash Mount Faucet
- Custom Sizes Available

STRAIGHT SOILED DISHTABLES LEFT TO RIGHT (L) RIGHT TO LEFT (R)

Size (in)	L x W (in)	16 Gauge	Wt (lb)	14 Gauge	Wt (lb)
36	36x30	SDT-16-S-36-L	75	SDT-14-S-36-L	85
		SDT-16-S-36-R		SDT-14-S-36-R	
48	48x30	SDT-16-S-48-L	90	SDT-14-S-48-L	99
		SDT-16-S-48-R		SDT-14-S-48-R	
60	60x30	SDT-16-S-60-L	100	SDT-14-S-60-L	110
		SDT-16-S-60-R		SDT-14-S-60-R	
72	72x30	SDT-16-S-72-L	120	SDT-14-S-72-L	132
		SDT-16-S-72-R		SDT-14-S-72-R	
84	84x30	SDT-16-S-84-L	130	SDT-14-S-84-L	143
		SDT-16-S-84-R		SDT-14-S-84-R	
96	96x30	SDT-16-S-96-L	140	SDT-14-S-96-L	154
		SDT-16-S-96-R		SDT-14-S-96-R	



CDT-16-S-36-L

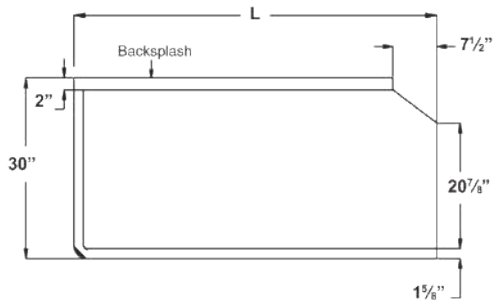

STRAIGHT CLEAN DISHTABLES LEFT TO RIGHT (L) RIGHT TO LEFT (R)

Size (in)	L x W (in)	16 Gauge	Wt (lb)	14 Gauge	Wt (lb)
24	24x30	CDT-16-S-24-L	25	CDT-14-S-24-L	29
		CDT-16-S-24-R		CDT-14-S-24-R	
36	36x30	CDT-16-S-36-L	40	CDT-14-S-36-L	44
		CDT-16-S-36-R		CDT-14-S-36-R	
48	48x30	CDT-16-S-48-L	50	CDT-14-S-48-L	55
		CDT-16-S-48-R		CDT-14-S-48-R	
60	60x30	CDT-16-S-60-L	60	CDT-14-S-60-L	66
		CDT-16-S-60-R		CDT-14-S-60-R	
72	72x30	CDT-16-S-72-L	80	CDT-14-S-72-L	88
		CDT-16-S-72-R		CDT-14-S-72-R	
84	84x30	CDT-16-S-84-L	100	CDT-14-S-84-L	110
		CDT-16-S-84-R		CDT-14-S-84-R	
96	96x30	CDT-16-S-96-L	110	CDT-14-S-96-L	121
		CDT-16-S-96-R		CDT-14-S-96-R	

OPTIONS: WB18 18" Wall Brackets
All Freight Class: 150

CORNER SOILED DISHTABLES LEFT TO RIGHT (L) RIGHT TO LEFT (R)



Size (in)	L x W (in)	16 Gauge	Wt (lb)	14 Gauge	Wt (lb)
48	48x30	SDT-16-C-48-L	90	SDT-14-C-48-L	99
		SDT-16-C-48-R		SDT-14-C-48-R	
60	60x30	SDT-16-C-60-L	100	SDT-14-C-60-L	110
		SDT-16-C-60-R		SDT-14-C-60-R	
72	72x30	SDT-16-C-72-L	120	SDT-14-C-72-L	132
		SDT-16-C-72-R		SDT-14-C-72-R	
84	84x30	SDT-16-C-84-L	130	SDT-14-C-84-L	143
		SDT-16-C-84-R		SDT-14-C-84-R	
96	96x30	SDT-16-C-96-L	140	SDT-14-C-96-L	154
		SDT-16-C-96-R		SDT-14-C-96-R	
120	120x30	SDT-16-C-120-L	160	SDT-14-C-120-L	176
		SDT-16-C-120-R		SDT-14-C-120-R	
144	144x30	SDT-16-C-144-L	176	SDT-14-C-144-L	211
		SDT-16-C-144-R		SDT-14-C-120-R	



SDT-16-C-60-L

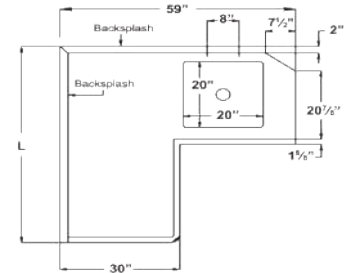

Custom sizes available.
Call us for a quote.

CORNER CLEAN DISHTABLES LEFT TO RIGHT (L) RIGHT TO LEFT (R)

Size (in)	L x W (in)	16 Gauge	Wt (lb)	14 Gauge	Wt (lb)
48	48x30	CDT-16-C-48-L	50	CDT-14-C-48-L	55
		CDT-16-C-48-R		CDT-14-C-48-R	
60	60x30	CDT-16-C-60-L	60	CDT-14-C-60-L	66
		CDT-16-C-60-R		CDT-14-C-60-R	
72	72x30	CDT-16-C-72-L	80	CDT-14-C-72-L	88
		CDT-16-C-72-R		CDT-14-C-72-R	
84	84x30	CDT-16-C-84-L	100	CDT-14-C-84-L	110
		CDT-16-C-84-R		CDT-14-C-84-R	
96	96x30	CDT-16-C-96-L	110	CDT-14-C-96-L	121
		CDT-16-C-96-R		CDT-14-C-96-R	
120	120x30	CDT-16-C-120-L	140	CDT-14-C-120-L	150
		CDT-16-C-120-R		CDT-14-C-120-R	
144	144x30	CDT-16-C-144-L	168	CDT-14-C-144-L	178
		CDT-16-C-144-R		CDT-14-C-144-R	



CDT-16-C-60-L

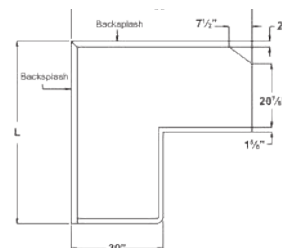

OPTIONS: WB18 18" Wall Brackets
All Freight Class: 150



SDT-16-I-60-R

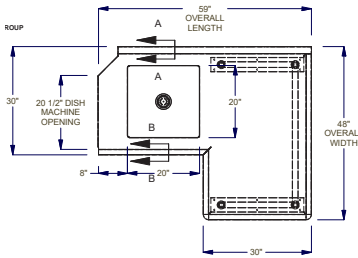

Sink Hardware Sold Separately



CDT-16-I-60-R

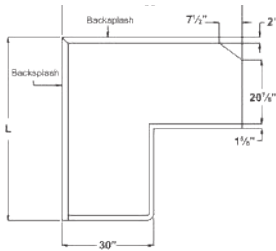

- Island Stainless Steel Dishtables
- Constructed of 16 GA or 14 GA 300 series stainless
- Soiled table has a 20" x 20" x 8"D pre-rinse bowl to accept 3 1/2" drain basket
- Backsplash punched to accept faucets on 8" centers
- Backsplash is 9" high, with 2" 45° return to wall
- 37" to top of rolled rim
- Right to Left (R) connects to right side of machine.
- Left to Right (L) connects to left side of machine.



ISLAND SOILED DISHTABLES LEFT TO RIGHT (L) RIGHT TO LEFT (R)

Size (in)	L x W (in)	16 Gauge	Wt (lb)	14 Gauge	Wt (lb)
48	48x30	SDT-16-I-48-L	90	SDT-14-I-48-L	85
		SDT-16-I-48-R		SDT-14-I-48-R	
60	60x30	SDT-16-I-60-L	100	SDT-14-I-60-L	99
		SDT-16-I-60-R		SDT-14-I-60-R	
72	72x30	SDT-16-I-72-L	120	SDT-14-I-72-L	110
		SDT-16-I-72-R		SDT-14-I-72-R	
84	84x30	SDT-16-I-84-L	130	SDT-14-I-84-L	132
		SDT-16-I-84-R		SDT-14-I-84-R	
96	96x30	SDT-16-I-96-L	140	SDT-14-I-96-L	143
		SDT-16-I-96-R		SDT-14-I-96-R	
120	120x30	SDT-16-I-120-L	160	SDT-14-I-120-L	154
		SDT-16-I-120-R		SDT-14-I-120-R	
144	144x30	SDT-16-I-144-L	176	SDT-14-I-144-L	176
		SDT-16-I-144-R		SDT-14-I-144-R	

Sink Hardware Sold Separately.

ISLAND CLEAN DISHTABLES LEFT TO RIGHT (L) RIGHT TO LEFT (R)

Size (in)	L x W (in)	16 Gauge	Wt (lb)	14 Gauge	Wt (lb)
48	48x30	CDT-16-I-48-L	50	CDT-14-I-48-L	55
		CDT-16-I-48-R		CDT-14-I-48-R	
60	60x30	CDT-16-I-60-L	60	CDT-14-I-60-L	66
		CDT-16-I-60-R		CDT-14-I-60-R	
72	72x30	CDT-16-I-72-L	80	CDT-14-I-72-L	88
		CDT-16-I-72-R		CDT-14-I-72-R	
84	84x30	CDT-16-I-84-L	100	CDT-14-I-84-L	110
		CDT-16-I-84-R		CDT-14-I-84-R	
96	96x30	CDT-16-I-96-L	110	CDT-14-I-96-L	121
		CDT-16-I-96-R		CDT-14-I-96-R	
120	120x30	CDT-16-I-120-L	140	CDT-14-I-120-L	150
		CDT-16-I-120-R		CDT-14-I-120-R	
144	144x30	CDT-16-I-144-L	168	CDT-14-I-144-L	178
		CDT-16-I-144-R		CDT-14-I-144-R	

- Landing Ledge Stainless Steel Dishtables
- Constructed of 16 GA or 14 GA 300 series stainless
- Soiled table has a 20" x 20" x 8"D pre-rinse bowl to accept 3½" drain basket
- Backsplash punched to accept faucets on 8" centers
- Backsplash is 9" high, with 2" 45° degree return to wall
- 37" to top of rolled rim
- **Custom Sizes Available**



SDT-16-L-72-L

LANDED SOILED DISHTABLES LEFT TO RIGHT (L) RIGHT TO LEFT (R)

Size (in)	L x W (in)	16 Gauge	Wt (lb)	14 Gauge	Wt (lb)
48	48x30	SDT-16-L-48-L	175	SDT-14-L-48-L	193
		SDT-16-L-48-R		SDT-14-L-48-R	
60	60x30	SDT-16-L-60-L	195	SDT-14-L-60-L	215
		SDT-16-L-60-R		SDT-14-L-60-R	
72	72x30	SDT-16-L-72-L	225	SDT-14-L-72-L	248
		SDT-16-L-72-R		SDT-14-L-72-R	
84	84x30	SDT-16-L-84-L	240	SDT-14-L-84-L	264
		SDT-16-L-84-R		SDT-14-L-84-R	
96	96x30	SDT-16-L-96-L	255	SDT-14-L-96-L	281
		SDT-16-L-96-R		SDT-14-L-96-R	
120	120x30	SDT-16-L-120-L	285	SDT-14-L-120-L	314
		SDT-16-L-120-R		SDT-14-L-120-R	
144	144x30	SDT-16-L-144-L	300	SDT-14-L-144-L	346
		SDT-16-L-144-R		SDT-14-L-144-R	

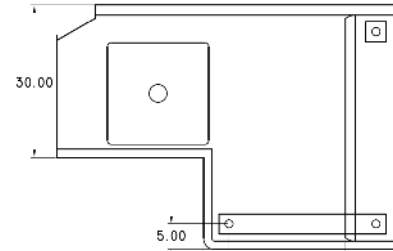

16 Gauge, 300 series stainless steel dishtables and legs with stainless steel clad bullet feet. Fabricated bowls are 12" deep water level.

14 Gauge, 300 series stainless steel dishtables and legs with stainless steel clad bullet feet. Fabricated bowls are 14" deep water level.

- Use where space is limited
- Sanitary stainless steel top is constructed of all welded 16 gauge stainless steel
- Stainless steel bullet feet that adjusts to 1³/₈"
- Pre-rinse bowl is 20" x 20" x 8"
- Includes angle to secure to dishwasher
- 30" min. to fully cover dish machine

UNDERCOUNTER DISHTABLES LEFT (L) RIGHT (R)

Size (in)	L x W (in)	16 Gauge	Wt (lb)
48	48x30	UDT-16-L-48-L	90
		UDT-16-L-48-R	
60	60x30	UDT-16-L-60-L	100
		UDT-16-L-60-R	
72	72x30	UDT-16-L-72-L	110
		UDT-16-L-72-R	



UDT-16-L-60-R

OPTIONS: WB18 18" Wall Brackets
All Freight Class: 150

As part of our commitment to continuous product improvement, Winholt reserves the right to modify materials and specifications without prior notice.



SORTING SHELVES

- Designed for sorting of cups, glasses, and mugs
- 16 gauge 300 series stainless steel
- Mounts to backsplash and end roll of dish table
- Priced per linear foot

DOUBLE TABLE MOUNTED SHELF

Use Single shelf models below and add -DBL
 MODEL: SSWDT-XXXX(length)-DBL

SORTING SHELF SINGLE TABLE MOUNTED

# Racks	L x W (in)	Model Number	Wt (lb)
1	22x21	SSWDT2221-TB	20
2	42x21	SSWDT4222-TB	44
3	62x21	SSWDT6222-TB	60
4	82x21	SSWDT8222-TB	85

SORTING SHELF TUBULAR WALL MOUNTED

# Racks	L x W (in)	Model Number	Wt (lb)
1	22x21	SSWMDT2221	15
2	42x21	SSWMDT2142	23
3	62x21	SSWMDT2162	30
4	82x21	SSWMDT2182	38

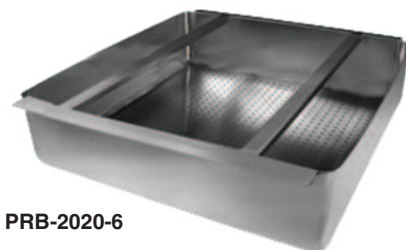
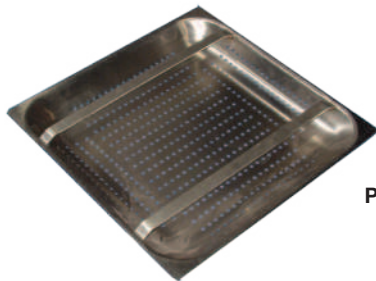

PRE-RINSE BASKETS & RACK SLIDE FOR DISH TABLES

Depth (in)	L x W (in)	Model Number	Wt (lb)
2.5	19½x19½	PRB2020-2.5	15
6	19½x19½	PRB2020-6	25
RACK SLIDE			
---	19½x19½	SSDRS-2020	4

DISHTABLE MODIFICATIONS

MODEL	DESCRIPTION	SOLD BY	MODEL	DESCRIPTION	SOLD BY
Top Modifications			Sink Bowl Modifications		
WH-SCBL	Scrap Block Installed	each	WH-LVSB	Lever Support Bracket	each
WH-ASBH	Anti. Siphon Vacuum Breaker Holes	each	WH-WS-RLWV-OF	Lever Waste Drain w/ Overflow	each
WH-WFJ	Welded Field Joint <i>(by other)</i>	each	WH-CT12XXXX	Custom bowl 12" deep	each
WH-DSCB	Installation of Disposal Cone with 6" x 9" control bracket, faucet holes <i>(Cone supplied by other)</i>	each	WH-CT14XXXX	Custom bowl 14" deep	each
WH-DSCB14	Installation of Disposal Cone with 14" x 16" control bracket, faucet holes <i>(Cone supplied by other)</i>	each	WH-CT16XXXX	Custom bowl 16" deep	each
WH-WATRG	Waste trough with removable basket - 2" deep	each	WH-CTMOD	Modify Bowl Depth	each
WH-COLLAR	Installation of collar with each 6" x 9" control bracket <i>(Collar supplied by other)</i>	each	Drainboard Modifications		
WH-FAUCLOC	Special faucet hole location	each	WH-EXDB	Extra Drainboard	per lin. ft.
WH-LAND	Landing Ledge	per. lin. ft.	WH-DBCTN	Corner Turn for Drainboard	each
Base Modifications			WH-USDB	Undershelf Drainboard	per lin. ft.
WH-HFLEG	H-Frame Support Leg	each	Additional Crating Costs		
WH-CBH	Holder for Cutting Board / Sink Cover	each	WH-CRATE	Complete Crating	per table
WS-SDDEAD	Sound Deadening Spray	per lin. ft.	WH-EXPCRATE	Export Crating	per table
Backsplash & Sidesplash Modifications			Stainless Steel Sink Cover for Sink Bowls		
WH-SPCU	Splash cutout	each	WSA-SSC1014	S/S Sink Cover, 14"L x 10"W bowl	each
WH-BS13	Backsplash up to 13"	per lin. ft.	WSA-SSC1416	S/S Sink Cover, 16"L x 14"W bowl	each
WH-BS18	Backsplash up to 18"	per lin. ft.	WSA-SSC1618	S/S Sink Cover, 18"L x 16"W bowl	each
WH-SSP	Sink Sidesplash	each	WSA-SSC1818	S/S Sink Cover, 18"L x 18"W bowl	each
WH-SSI	Integrated Sidesplash	per lin. ft.	WSA-SSC1620	S/S Sink Cover, 20"L x 16"W bowl	each
WH-ABS	Add 5" Backsplash	per lin. ft.	WSA-SSC2020	S/S Sink Cover, 20"L x 20"W bowl	each
WH-PASST	Pass Thru	per lin. ft.	WSA-SSC1824	S/S Sink Cover, 24"L x 18"W bowl	each
BRAND MODIFICATION			WSA-SSC2424	S/S Sink Cover, 24"L x 24"W bowl	each
American Dish Machine			WSA-SSC1928	S/S Sink Cover, 28"L x 19"W bowl	each
HT-25, SS-25		WH-NBS-AMERICAN	WSA-SSC2028	S/S Sink Cover, 28"L x 20"W bowl	each
Blakeslee			WSA-SSC1532	S/S Sink Cover, 32"L x 15"W bowl	each
D-8, D-9		WH-NBS-BLAKESLEE	Poly Top Sink Cover for Sink Bowls		
CMA			WSA-PSC1618	Poly Sink Cover, 18"L x 16"W bowl	each
180, 44, 66		WH-RLSBL-CMA	WSA-PSC1818	Poly Sink Cover, 18"L x 18"W bowl	each
Ecolab			WSA-PSC1620	Poly Sink Cover, 20"L x 16"W bowl	each
ES-4000, ES-4400, ES-6600, WH-Series		WH-RLSBL-ECOLAB	WSA-PSC2020	Poly Sink Cover, 20"L x 20"W bowl	each
Electrolux			WSA-PSC-1824	Poly Sink Cover, 24"L x 18"W bowl	each
WT-65		WH-RLSBL-ELECTROLUX	WSA-PSC2424	Poly Sink Cover, 24"L x 24"W bowl	each
Hobart			WSA-PSC1928	Poly Sink Cover, 28"L x 19"W bowl	each
C-Series, CL-Series, CRS-Series, CCS-66//77/86/110, AM-15 (located in corner)		WH-RLSBL-HOBART	WSA-PSC2028	Poly Sink Cover, 28"L x 20"W bowl	each
Jackson			WSA-PSC1532	Poly Sink Cover, 32"L x 15"W bowl	each
AJ-Series, TS-Series, TSC-Series		WH-RLSBL-JACKSON	Leg Accessories		
Meiko			4497-3	Flanged stainless steel bullet foot	each
K-Series, Steroi		WH-RLSBL-MEIKO	4471	Stainless steel bullet clad foot	each
			WH-RSB	Replacement rubber scrap block for WH-SCBL	each
			WH-LWB	Leg to wall brace	each
			Sorting Shelf		
			SSTMT-XXXX-DBL	Table Mount Tubular Sorting Shelf, Double	per lin. ft.
			SSWMDT2221-TB	21"L Wall Mount Tubular Sorting Shelf	each
			SSWMDT-2242-TB	42"L Wall Mount Tubular Sorting Shelf	each
			SSWMDT-2263-TB	63"L Wall Mount Tubular Sorting Shelf	each
			SSWMDT2283-TB	83"L Wall Mount Tubular Sorting Shelf	each



Sink Hardware Sold Separately

SINK HARDWARE

Standard Sink Faucets



14" Swing Faucet
Splash Mount
Model WS-SF-14ST

Standard Pre-Rinse and Add-On Faucets



Wall Mount
Pre-Rinse Spring
Type with Chrome
Hose Cover
Model
WS-SPR-ST



Add on 14" Swing Faucet Model
WS-SFSM-14ST-ENC
(Use on WS-SPR-ST)

Pre-Rinse



14" Add On Faucet
Model WS-SFSM-14ST
(Use on WS-SPR-ST)

Premium Add-On Faucets



Add on 14" Swing
Faucet
Model WS-SFSM-14SU
(Use on WS-SPR-SU)

Sink Faucets

Splash Mount
14" Swing Faucet
Model WS-SF-14ST-LF



Splash Mount
12" Swing Faucet
Model WS-SF-12ST



Splash Mount
8" Swing Faucet
Model WS-SF-8ST



Hand Sink Faucets

Electronic Eye Faucet
Model WS-GSEM-6SP
(Use on WSHS-1410-EF)



4" Gooseneck
Faucet
Model WS-
GNECK
(Use on
WSHS-1410-5-F)



12" Gooseneck Rigid
Faucet
Model WS-GS-ST
(Use on
WWHS1410SP)



SINK HARDWARE

Basket Drains



Basket Drain 1 1/2"
Model WS-BD-15ST



Basket Drain 3 1/2"
Model WS-BD-35ST

Standard Line - Lever Drain



**Rotary Lever Waste Valve
with Flat Strainer**
Model WS-RLWV-ST

Foot Pedals

Single Foot Pedal
Model WS-FP-K252000
(Use on WHPS1110)



Double Foot Pedals
Model WS-FP-ST
(Use on WHPS1616)

Knee Valves

Knee Valves
Model WS-KV-ST
(Use on WWHS1410SP)



Thermo Mixing Valve



**Thermo
Mixing Valve**
Model WS-TMV-ST
(Use on WHPS1110)

Water Station



Complete Water Station
Model WS-CWS-K271000

Soap Dispenser



Soap Dispenser
Model WS-SD-ST



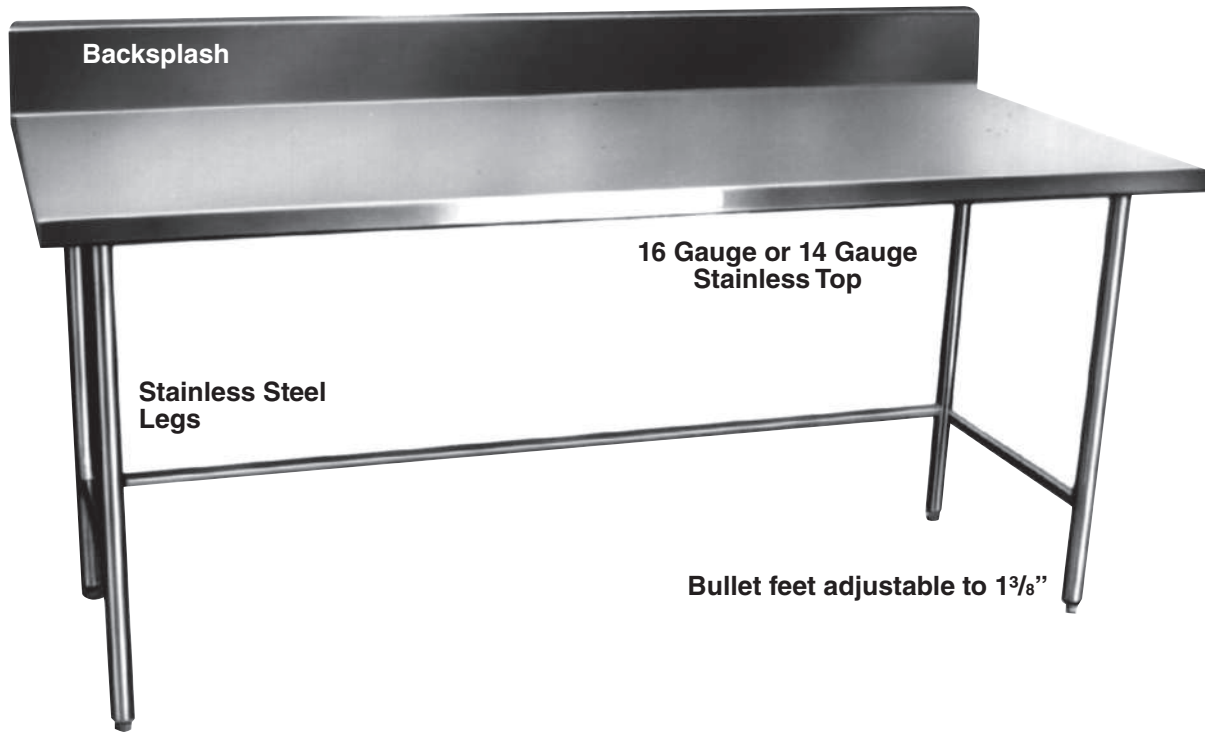

Stainless Steel Tables - Model Number Chart		
Model Number: DTR-2436		
Table Type	Table Size	Gauge
DTR <i>Flat Top, Open Base w/ Cross Rails</i>	-2436 <i>24"W x 36"L</i>	<i>16 Gauge</i>
Stainless Steel Table w/ Open Base and Cross Rails, No Backsplash		

Stainless Steel Enclosed Base Tables - Model Number Chart					
Model Number: STCT-BBHD2460-MS					
Table Type	Backsplash	Door Type	Table Size	Shelving	Gauge
STCT <i>Enclosed Base Table</i>	-BB <i>Boxed Backsplash</i>	HD <i>Hinged Doors</i>	2460 <i>24"W x 60"L</i>	-MS <i>(1) Midshelf</i>	<i>16 Gauge</i>
Boxed Backsplash, Hinged Door w/ Undershef, 16 Gauge					

- All 16 gauge 300 series stainless steel top, shelves, and 18 GA legs
- 6" Backsplash
- 1⁵/₈" Diameter 16 gauge stainless steel tubing
- 34" Height with stainless steel bullet feet that adjusts to 1³/₈"
- Stainless steel hat channels deaden sound and reinforce the top to maintain a level work surface.
- Undershelf is 18 gauge
- 96" Tables are standard with six legs



Backsplash

STAINLESS STEEL WORK TABLES WITH BACKSPLASH

Width (in)	Length (in)	16 Gauge	Wt (lb)
24	36	DTB-2436	59
	48	DTB-2448	71
	60	DTB-2460	82
	72	DTB-2472	94
	84	DTB-2484	110
	96	DTB-2496	126
30	36	DTB-3036	65
	48	DTB-3048	78
	60	DTB-3060	91
	72	DTB-3072	104
	84	DTB-3084	120
	96	DTB-3096	139
36	36	DTB-3636	70
	48	DTB-3648	79
	60	DTB-3660	90
	72	DTB-3672	105
	84	DTB-3684	125
	96	DTB-3696	141



DTB-3036

Freight Class: 300

STAINLESS STEEL WORK TABLES WITH STAINLESS STEEL UNDERSHELF & BACKSPLASH

Width (in)	Length (in)	16 Gauge	Wt (lb)
24	36	DTSB-2436	65
	48	DTSB-2448	81
	60	DTSB-2460	95
	72	DTSB-2472	111
	84	DTSB-2484	131
	96	DTSB-2496	147
30	36	DTSB-3036	73
	48	DTSB-3048	90
	60	DTSB-3060	109
	72	DTSB-3072	126
	84	DTSB-3084	142
	96	DTSB-3096	168
36	36	DTSB-3636	81
	48	DTSB-3648	95
	60	DTSB-3660	111
	72	DTSB-3672	132
	84	DTSB-3684	151
	96	DTSB-3696	177



DTSB-3072

Freight Class: 300

As part of our commitment to continuous product improvement, Winholt reserves the right to modify materials and specifications without prior notice.



DPTR-3036



DPTB-3036



DPTS-3048

- All 16 gauge 300 series stainless steel tops, and back splash
- 5" High back splash
- 34" Height with stainless steel bullet feet that adjusts to 1³/₈"
- Legs and cross bracing are 1⁵/₈" diameter 18 gauge stainless steel tubing
- Stainless steel hat channels deaden sound and reinforce the top to maintain a level work surface.
- 18 Gauge stainless steel undershelf (DPTS/DPTSB SERIES)
- Poly top is 5/8" thick and sectioned for easy removal. Polytop clips (model 3115-033) are removeable. 3/4" poly tops available upon request.
- 96" Long tables are standard with six legs

STAINLESS STEEL POLY TOP WORK TABLES

Width (in)	Length (in)	Open Base	Wt (lb)	Open Base w/ Backsplash	Wt (lb)
24	36	DPTR-2436	54	DPTB-2436	59
	48	DPTR-2448	64	DPTB-2448	71
	60	DPTR-2460	74	DPTB-2460	82
	72	DPTR-2472	84	DPTB-2472	94
	84	DPTR-2484	94	DPTB-2484	110
	96	DPTR-2496	114	DPTB-2496	126
30	36	DPTR-3036	60	DPTB-3036	65
	48	DPTR-3048	72	DPTB-3048	78
	60	DPTR-3060	83	DPTB-3060	91
	72	DPTR-3072	95	DPTB-3072	104
	84	DPTR-3084	115	DPTB-3084	120
	96	DPTR-3096	126	DPTB-3096	139
36	36	DPTR-3636	69	DPTB-3636	70
	48	DPTR-3648	79	DPTB-3648	79
	60	DPTR-3660	92	DPTB-3660	90
	72	DPTR-3672	105	DPTB-3672	105
	84	DPTR-3684	116	DPTB-3684	125
	96	DPTR-3696	140	DPTB-3696	135

STAINLESS STEEL POLY TOP WORK TABLES WITH UNDERSHELF

Width (in)	Length (in)	w/ Undershelf	Wt (lb)	w/ Undershelf & Backsplash	Wt (lb)
24	36	DPTS-2436	60	DPTSB-2436	65
	48	DPTS-2448	73	DPTSB-2448	81
	60	DPTS-2460	86	DPTSB-2460	95
	72	DPTS-2472	100	DPTSB-2472	111
	84	DPTS-2484	120	DPTSB-2484	131
	96	DPTS-2496	134	DPTSB-2496	147
30	36	DPTS-3036	73	DPTSB-3036	73
	48	DPTS-3048	84	DPTSB-3048	90
	60	DPTS-3060	100	DPTSB-3060	109
	72	DPTS-3072	116	DPTSB-3072	126
	84	DPTS-3084	136	DPTSB-3084	142
	96	DPTS-3096	155	DPTSB-3096	168
36	36	DPTS-3636	82	DPTSB-3636	81
	48	DPTS-3648	94	DPTSB-3648	95
	60	DPTS-3660	113	DPTSB-3660	111
	72	DPTS-3672	131	DPTSB-3672	132
	84	DPTS-3684	150	DPTSB-3684	151
	96	DPTS-3696	160	DPTSB-3696	162

All Freight Class: 300

STAINLESS STEEL WORK TABLES



- All welded construction
- 16 GA and 14 GA stainless steel
- All TIG welded and shipped set up. High polish finish.
- 34" Height with stainless steel bullet feet that adjusts to 1³/₈"
- Legs and cross bracing are 1⁵/₈" diameter 16 gauge stainless steel tubing
- Stainless steel hat channels deaden sound and reinforce the top to maintain a level work surface
- 96" Long tables are standard with six legs



DTR-3048



DTS-3048

Width (in)	Length (in)	16 Gauge	Wt (lb)	14 Gauge	Wt (lb)
24	36	DTR-2436	54	DTR-2436-14	95
	48	DTR-2448	64	DTR-2448-14	110
	60	DTR-2460	74	DTR-2460-14	120
	72	DTR-2472	84	DTR-2472-14	130
	84	DTR-2484	94	DTR-2484-14	170
	96	DTR-2496	114	DTR-2496-14	180
30	36	DTR-3036	60	DTR-3036-14	105
	48	DTR-3048	72	DTR-3048-14	120
	60	DTR-3060	83	DTR-3060-14	130
	72	DTR-3072	95	DTR-3072-14	140
	84	DTR-3084	115	DTR-3084-14	185
	96	DTR-3096	126	DTR-3096-14	200
36	36	DTR-3636	69	DTR-3636-14	120
	48	DTR-3648	79	DTR-3648-14	130
	60	DTR-3660	92	DTR-3660-14	145
	72	DTR-3672	105	DTR-3672-14	160
	84	DTR-3684	116	DTR-3684-14	200
	96	DTR-3696	140	DTR-3696-14	220
w/ Undershelf					
24	36	DTS-2436	60	DTS-2436-14	95
	48	DTS-2448	73	DTS-2448-14	110
	60	DTS-2460	86	DTS-2460-14	120
	72	DTS-2472	100	DTS-2472-14	135
	84	DTS-2484	120	DTS-2484-14	170
	96	DTS-2496	134	DTS-2496-14	185
30	36	DTS-3036	73	DTS-3036-14	115
	48	DTS-3048	84	DTS-3048-14	120
	60	DTS-3060	100	DTS-3060-14	130
	72	DTS-3072	116	DTS-3072-14	140
	84	DTS-3084	136	DTS-3084-14	185
	96	DTS-3096	155	DTS-3096-14	200
36	36	DTS-3636	82	DTS-3636-14	125
	48	DTS-3648	94	DTS-3648-14	135
	60	DTS-3660	113	DTS-3660-14	145
	72	DTS-3672	131	DTS-3672-14	160
	84	DTS-3684	150	DTS-3684-14	200
	96	DTS-3696	177	DTS-3696-14	220

OPTIONS: WB18 18" WALL BRACKETS
Freight Class: 300

STAINLESS STEEL WORK TABLES WITH BACKSPLASH



Boxed Backsplash
 6" backsplash, 2" depth, 45° slope angle and
 1" turn down edge
Shown with optional rolled edge

Width (in)	Length (in)	16 Gauge	Wt (lb)	14 Gauge	Wt (lb)
24	36	DTBB-2436	90	DTBB-2436-14	90
	48	DTBB-2448	100	DTBB-2448-14	100
	60	DTBB-2460	110	DTBB-2460-14	110
	72	DTBB-2472	120	DTBB-2472-14	120
	84	DTBB-2484	145	DTBB-2484-14	145
	96	DTBB-2496	160	DTBB-2496-14	160
30	36	DTBB-3036	100	DTBB-3036-14	100
	48	DTBB-3048	115	DTBB-3048-14	115
	60	DTBB-3060	145	DTBB-3060-14	145
	72	DTBB-3072	155	DTBB-3072-14	155
	84	DTBB-3084	170	DTBB-3084-14	170
	96	DTBB-3096	185	DTBB-3096-14	185
36	36	DTBB-3636	105	DTBB-3636-14	105
	48	DTBB-3648	115	DTBB-3648-14	115
	60	DTBB-3660	145	DTBB-3660-14	145
	72	DTBB-3672	155	DTBB-3672-14	155
	84	DTBB-3684	170	DTBB-3684-14	170
	96	DTBB-3696	185	DTBB-3696-14	185
w/ Undershaft					
24	36	DTSBB-2436	100	DTSBB-2436-14	100
	48	DTSBB-2448	115	DTSBB-2448-14	115
	60	DTSBB-2460	135	DTSBB-2460-14	135
	72	DTSBB-2472	150	DTSBB-2472-14	150
	84	DTSBB-2484	175	DTSBB-2484-14	180
	96	DTSBB-2496	200	DTSBB-2496-14	200
30	36	DTSBB-3036	110	DTSBB-3036-14	110
	48	DTSBB-3048	130	DTSBB-3048-14	130
	60	DTSBB-3060	140	DTSBB-3060-14	140
	72	DTSBB-3072	165	DTSBB-3072-14	165
	84	DTSBB-3084	198	DTSBB-3084-14	200
	96	DTSBB-3096	215	DTSBB-3096-14	215
36	36	DTSBB-3636	120	DTSBB-3636-14	125
	48	DTSBB-3648	135	DTSBB-3648-14	140
	60	DTSBB-3660	145	DTSBB-3660-14	155
	72	DTSBB-3672	170	DTSBB-3672-14	180
	84	DTSBB-3684	205	DTSBB-3684-14	220
	96	DTSBB-3696	220	DTSBB-3696-14	235



DTBB-3048



DTSBB-3048

OPTIONS: WB18 18" WALL BRACKETS
 Freight Class: 300

STAINLESS STEEL MAPLE WOOD TOP TABLES

- Frame constructed of 16 gauge stainless steel
- 34" Height with stainless steel bullet feet that adjusts to 1³/₈"
- ¾" Hard laminated maple wood top with edge grain, electronically bonded
- 2" Maple is available upon request
- 96" Long tables are standard with six legs
- 18 Gauge stainless steel undershelf and legs

Width (in)	Length (in)	16 Gauge	Wt (lb)
36	48	WTS3648	100
	60	WTS3660	120
	72	WTS3672	140
	96	WTS3696	160
w/ Undershelf			
36	48	WTSS3648	120
	60	WTSS3660	140
	72	WTSS3672	160
	96	WTSS3696	200



WTS3660



WTSS3660

ENCLOSED BASE TABLES

- Sanitary stainless steel top is constructed of all welded 16 gauge stainless steel.
- 6" High stainless steel backsplash no return
- Sliding Doors:
 - 36"-72" tables have 2 doors
 - 84"-144" tables have 4 doors
- 34" Height with stainless steel bullet feet that adjusts to 1³/₈"
- 96" long tables are standard with six legs

Width (in)	Length (in)	16 Gauge	Wt (lb)
24	36	STCT-BD2436	104
	48	STCT-BD2448	120
	60	STCT-BD2460	140
	72	STCT-BD2472	166
	84	STCT-BD2484	190
	96	STCT-BD2496	211
30	36	STCT-BD3036	118
	48	STCT-BD3048	133
	60	STCT-BD3060	156
	72	STCT-BD3072	186
	84	STCT-BD3084	205
	96	STCT-BD3096	234

All Freight Class: 300

Maple Wood Tops are an available option for our enclosed base tables.



STCT-BD3060

As part of our commitment to continuous product improvement, Winholt reserves the right to modify materials and specifications without prior notice.

- Sanitary stainless steel top is constructed of all welded 16 gauge stainless steel
- 34" Height with stainless steel bullet feet that adjusts to 1³/₈"
- Available with a stationary mid-shelf
- Hinged Doors:
 - 36"-72" have 2 doors
 - 84"-120" have 4 doors
 - 144" has 6 doors
- Sliding Doors:
 - 36"-72" have 2 doors
 - 84"-144" have 4 doors
- 96" Long tables are standard with six legs
- **Custom Sizes Available**



STCT-HD2472

Winholt has 14% more storage space than our competitors on our 24" wide tables and 12% more storage space on our 30" wide tables

ENCLOSED BASE TABLES – FLAT TOP

Width (in)	Length (in)	Open Table w/ No Shelf	Open Table w/ Shelf	Wt (lb)	Table w/ Hinged Doors No Shelf	Table w/ Hinged Doors w/ Shelf	Table w/ Sliding Doors No Shelf	Table w/ Sliding Doors w/ Shelf	Wt (lb)
24	36	STCT-2436	STCT-2436-MS	75	STCT-HD2436	STCT-HD2436-MS	STCT-D2436	STCT-D2436-MS	90
	48	STCT-2448	STCT-2448-MS	100	STCT-HD2448	STCT-HD2448-MS	STCT-D2448	STCT-D2448-MS	120
	60	STCT-2460	STCT-2460-MS	125	STCT-HD2460	STCT-HD2460-MS	STCT-D2460	STCT-D2460-MS	150
	72	STCT-2472	STCT-2472-MS	150	STCT-HD2472	STCT-HD2472-MS	STCT-D2472	STCT-D2472-MS	180
	84	STCT-2484	STCT-2484-MS	175	STCT-HD2484	STCT-HD2484-MS	STCT-D2484	STCT-D2484-MS	210
	96	STCT-2496	STCT-2496-MS	200	STCT-HD2496	STCT-HD2496-MS	STCT-D2496	STCT-D2496-MS	240
30	36	STCT-3036	STCT-3036-MS	85	STCT-HD3036	STCT-HD3036-MS	STCT-D3036	STCT-D3036-MS	95
	48	STCT-3048	STCT-3048-MS	110	STCT-HD3048	STCT-HD3048-MS	STCT-D3048	STCT-D3048-MS	125
	60	STCT-3060	STCT-3060-MS	135	STCT-HD3060	STCT-HD3060-MS	STCT-D3060	STCT-D3060-MS	155
	72	STCT-3072	STCT-3072-MS	160	STCT-HD3072	STCT-HD3072-MS	STCT-D3072	STCT-D3072-MS	185
	84	STCT-3084	STCT-3084-MS	185	STCT-HD3084	STCT-HD3084-MS	STCT-D3084	STCT-D3084-MS	215
	96	STCT-3096	STCT-3096-MS	210	STCT-HD3096	STCT-HD3096-MS	STCT-D3096	STCT-D3096-MS	245
36	36	STCT-3636	STCT-3636-MS	100	STCT-HD3636	STCT-HD3636-MS	STCT-D3636	STCT-D3636-MS	124
	48	STCT-3648	STCT-3648-MS	132	STCT-HD3648	STCT-HD3648-MS	STCT-D3648	STCT-D3648-MS	150
	60	STCT-3660	STCT-3660-MS	162	STCT-HD3660	STCT-HD3660-MS	STCT-D3660	STCT-D3660-MS	186
	72	STCT-3672	STCT-3672-MS	192	STCT-HD3672	STCT-HD3672-MS	STCT-D3672	STCT-D3672-MS	222
	84	STCT-3684	STCT-3684-MS	222	STCT-HD3684	STCT-HD3684-MS	STCT-D3684	STCT-D3684-MS	258
	96	STCT-3696	STCT-3696-MS	252	STCT-HD3696	STCT-HD3696-MS	STCT-D3696	STCT-D3696-MS	294

OPTIONS: WB18 18" WALL BRACKETS
Freight Class: 300

- Sanitary stainless steel top is constructed of all welded 16 gauge stainless steel
- 34" Height with stainless steel bullet feet that adjusts to 1³/₈"
- Available with a stationary mid-shelf
- Hinged Doors:
 - 36"-72" have 2 doors
 - 84"-120" have 4 doors
 - 144" has 6 doors
- Sliding Doors:
 - 36"-72" have 2 doors
 - 84"-144" have 4 doors
- 6" High stainless boxed backsplash with 45 degree return
- 96" Long tables are standard with six legs
- **Custom Sizes Available**



Boxed Backsplash



STCT-BBD2460

ENCLOSED BASE TABLES – 5" HIGH BOXED BACKSPLASH

Width (in)	Length (in)	Open Table w/ No Shelf	Open Table w/ Shelf	Wt (lb)	Table w/ Hinged Doors No Shelf	Table w/ Hinged Doors w/ Shelf	Table w/ Sliding Doors No Shelf	Table w/ Sliding Doors w/ Shelf	Wt (lb)
24	36	STCT-BB2436	STCT-BB2436-MS	80	STCT-BBHD2436	STCT-BBHD2436-MS	STCT-BBD2436	STCT-BBD2436-MS	95
	48	STCT-BB2448	STCT-BB2448-MS	105	STCT-BBHD2448	STCT-BBHD2448-MS	STCT-BBD2448	STCT-BBD2448-MS	125
	60	STCT-BB2460	STCT-BB2460-MS	130	STCT-BBHD2460	STCT-BBHD2460-MS	STCT-BBD2460	STCT-BBD2460-MS	155
	72	STCT-BB2472	STCT-BB2472-MS	155	STCT-BBHD2472	STCT-BBHD2472-MS	STCT-BBD2472	STCT-BBD2472-MS	185
	84	STCT-BB2484	STCT-BB2484-MS	180	STCT-BBHD2484	STCT-BBHD2484-MS	STCT-BBD2484	STCT-BBD2484-MS	215
	96	STCT-BB2496	STCT-BB2496-MS	205	STCT-BBHD2496	STCT-BBHD2496-MS	STCT-BBD2496	STCT-BBD2496-MS	245
30	36	STCT-BB3036	STCT-BB3036-MS	90	STCT-BBHD3036	STCT-BBHD3036-MS	STCT-BBD3036	STCT-BBD3036-MS	110
	48	STCT-BB3048	STCT-BB3048-MS	115	STCT-BBHD3048	STCT-BBHD3048-MS	STCT-BBD3048	STCT-BBD3048-MS	140
	60	STCT-BB3060	STCT-BB3060-MS	140	STCT-BBHD3060	STCT-BBHD3060-MS	STCT-BBD3060	STCT-BBD3060-MS	170
	72	STCT-BB3072	STCT-BB3072-MS	165	STCT-BBHD3072	STCT-BBHD3072-MS	STCT-BBD3072	STCT-BBD3072-MS	200
	84	STCT-BB3084	STCT-BB3084-MS	190	STCT-BBHD3084	STCT-BBHD3084-MS	STCT-BBD3084	STCT-BBD3084-MS	230
	96	STCT-BB3096	STCT-BB3096-MS	215	STCT-BBHD3096	STCT-BBHD3096-MS	STCT-BBD3096	STCT-BBD3096-MS	260
36	36	STCT-BB3636	STCT-BB3636-MS	108	STCT-BBHD3636	STCT-BBHD3636-MS	STCT-BBD3636	STCT-BBD3636-MS	128
	48	STCT-BB3648	STCT-BB3648-MS	138	STCT-BBHD3648	STCT-BBHD3648-MS	STCT-BBD3648	STCT-BBD3648-MS	168
	60	STCT-BB3660	STCT-BB3660-MS	168	STCT-BBHD3660	STCT-BBHD3660-MS	STCT-BBD3660	STCT-BBD3660-MS	204
	72	STCT-BB3672	STCT-BB3672-MS	198	STCT-BBHD3672	STCT-BBHD3672-MS	STCT-BBD3672	STCT-BBD3672-MS	240
	84	STCT-BB3684	STCT-BB3684-MS	228	STCT-BBHD3684	STCT-BBHD3684-MS	STCT-BBD3684	STCT-BBD3684-MS	276
	96	STCT-BB3696	STCT-BB3696-MS	258	STCT-BBHD3696	STCT-BBHD3696-MS	STCT-BBD3696	STCT-BBD3696-MS	312

OPTIONS: WB18 18" WALL BRACKETS
Freight Class: 300



- Sanitary stainless steel top is constructed of all welded 16 gauge stainless steel
- 34" Height with stainless steel bullet feet that adjust 1"
- Available with a stationary mid-shelf
- 1½" High stainless steel backsplash no return
- **Custom Sizes Available**

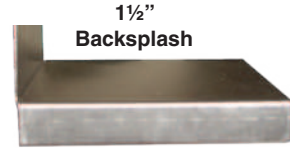

Winholt has 14% more storage space than our competitors on our 24" wide tables and 12% more storage space on our 30" wide tables

STCT-B15-3060

ENCLOSED BASE TABLES – 1½" BACKSPLASH

Width (in)	Length (in)	Open Table w/ No Shelf	Open Table w/ Shelf	Wt (lb)	Table w/ Hinged Doors No Shelf	Table w/ Hinged Doors w/ Shelf	Table w/ Sliding Doors No Shelf	Table w/ Sliding Doors w/ Shelf	Wt (lb)
24	36	STCT-B1.5-2436	STCT-B1.5-2436-MS	75	STCT-B1.5HD-2436	STCT-B1.5HD-2436-MS	STCT-B1.5D2436	STCT-B1.5D2436-MS	90
	48	STCT-B1.5-2448	STCT-B1.5-2448-MS	100	STCT-B1.5HD-2448	STCT-B1.5HD-2448-MS	STCT-B1.5D2448	STCT-B1.5D2448-MS	120
	60	STCT-B1.5-2460	STCT-B1.5-2460-MS	125	STCT-B1.5HD-2460	STCT-B1.5HD-2460-MS	STCT-B1.5D2460	STCT-B1.5D2460-MS	150
	72	STCT-B1.5-2472	STCT-B1.5-2472-MS	150	STCT-B1.5HD-2472	STCT-B1.5HD-2472-MS	STCT-B1.5D2472	STCT-B1.5D2472-MS	180
	84	STCT-B1.5-2484	STCT-B1.5-2484-MS	175	STCT-B1.5HD-2484	STCT-B1.5HD-2484-MS	STCT-B1.5D2484	STCT-B1.5D2484-MS	210
	96	STCT-B1.5-2496	STCT-B1.5-2496-MS	200	STCT-B1.5HD-2496	STCT-B1.5HD-2496-MS	STCT-B1.5D2496	STCT-B1.5D2496-MS	240
30	36	STCT-B1.5-3036	STCT-B1.5-3036-MS	85	STCT-B1.5HD-3036	STCT-B1.5HD-3036-MS	STCT-B1.5D3036	STCT-B1.5D3036-MS	95
	48	STCT-B1.5-3048	STCT-B1.5-3048-MS	110	STCT-B1.5HD-3048	STCT-B1.5HD-3048-MS	STCT-B1.5D3048	STCT-B1.5D3048-MS	125
	60	STCT-B1.5-3060	STCT-B1.5-3060-MS	135	STCT-B1.5HD-3060	STCT-B1.5HD-3060-MS	STCT-B1.5D3060	STCT-B1.5D3060-MS	155
	72	STCT-B1.5-3072	STCT-B1.5-3072-MS	160	STCT-B1.5HD-3072	STCT-B1.5HD-3072-MS	STCT-B1.5D3072	STCT-B1.5D3072-MS	185
	84	STCT-B1.5-3084	STCT-B1.5-3084-MS	185	STCT-B1.5HD-3084	STCT-B1.5HD-3084-MS	STCT-B1.5D3084	STCT-B1.5D3084-MS	215
	96	STCT-B1.5-3096	STCT-B1.5-3096-MS	210	STCT-B1.5HD-3096	STCT-B1.5HD-3096-MS	STCT-B1.5D3096	STCT-B1.5D3096-MS	245
36	36	STCT-B1.5-3636	STCT-B1.5-3636-MS	100	STCT-B1.5HD-3636	STCT-B1.5HD-3636-MS	STCT-B1.5D3636	STCT-B1.5D3636-MS	124
	48	STCT-B1.5-3648	STCT-B1.5-3648-MS	132	STCT-B1.5HD-3648	STCT-B1.5HD-3648-MS	STCT-B1.5D3648	STCT-B1.5D3648-MS	150
	60	STCT-B1.5-3660	STCT-B1.5-3660-MS	162	STCT-B1.5HD-3660	STCT-B1.5HD-3660-MS	STCT-B1.5D3660	STCT-B1.5D3660-MS	186
	72	STCT-B1.5-3672	STCT-B1.5-3672-MS	192	STCT-B1.5HD-3672	STCT-B1.5HD-3672-MS	STCT-B1.5D3672	STCT-B1.5D3672-MS	222
	84	STCT-B1.5-3684	STCT-B1.5-3684-MS	222	STCT-B1.5HD-3684	STCT-B1.5HD-3684-MS	STCT-B1.5D3684	STCT-B1.5D3684-MS	258
	96	STCT-B1.5-3696	STCT-B1.5-3696-MS	252	STCT-B1.5HD-3696	STCT-B1.5HD-3696-MS	STCT-B1.5D3696	STCT-B1.5D3696-MS	294

OPTIONS: WB18 18" WALL BRACKETS
 Freight Class: 300

TABLE OPTIONS



Bull Nose Edge



Marine Edge



**Backsplash
(Standard)**

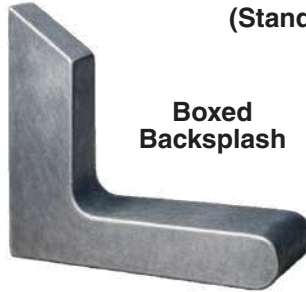

**Boxed
Backsplash**

**Turn Down Edge
(Standard)**

Rolled Edge



**Flanged Stainless Steel
Feet
(4497-3)**



Caster Options

- MS2LC: 4 leg table, 4 casters, includes 2 locking
- MS4LC: 4 leg table, 4 casters, includes 4 locking
- MS3LC: 6 leg table, 6 casters, includes 3 locking
- MS6LC: 6 leg table, 6 casters, includes 6 locking



**Integrated
Single Bowl
(WHPFB-101410-KIT)**

**End Splash
(WH-ESP)**

**Shown with Undershelf and
Rotary Lever Waste Valve**



**Trash Chute
(WH-TRASHCH)**



**Grommet Hole
(WH-GROMMET)**



**Urn Trough
(WH-URN)**



**Cup Dispenser Hole
(WH-DISPENSE)**

As part of our commitment to continuous product improvement, Winholt reserves the right to modify materials and specifications without prior notice.

800.444.3595 | sales@winholt.com | www.winholt.com



TABLE MODIFICATIONS

MODEL	DESCRIPTION	SOLD BY	MODEL	DESCRIPTION	SOLD BY
Integrated Single Bowl Welded in Top			Backsplash & Sidesplash Modifications		
WH-PFB-101410/KIT	10" x 14" x 10" Deep**	each	WH-SPCU	Splash Cutout	each
WH-PFB-141612/KIT	14" x 16" x 12" Deep	each	WH-BS13	Backsplash up to 13" SM Series	per lin. ft.
WH-PFB-16208/KIT	16" x 20" x 8" Deep	each	WH-BS18	Backsplash up to 18" SM Series	per lin. ft.
WH-PFB-162012/KIT	16" x 20" x 12" Deep	each	WH-BSBB13	Backsplash up to 13" FS/DC Series	per lin. ft.
WH-PFB-181812/KIT	18" x 18" x 12" Deep	each	WH-BSBB18	Backsplash up to 18" FS/DC Series	per lin. ft.
WH-PFB-182412/KIT	18" x 24" x 12" Deep	each	WH-SSP	Sink Sidesplash	each
WH-PFB-20208/KIT	20" x 20" x 8" Deep*	each	WH-SSI	Integrated sidesplash - SM Series	per lin. ft.
WH-PFB-202012/KIT	20" x 20" x 12" Deep*	each	WH-SSIBB	Integrated sidesplash -FS/DC Series	per lin. ft.
WH-PFB-242412/KIT	24" x 24" x 12" Deep**	each	WH-ABSBB	Add 5" Backsplash - FS/DC Series	per lin. ft.
WH-OMIT-FAUCET	Omit Faucet Kit	each	WH-ABS10BB	Add 10" Backsplash - FS/DC Series	per lin. ft.
<ul style="list-style-type: none"> Single sink bowl comes with 8" Deck Mount 4" O.C Swing Spout Faucet and Basket Drain 10" x 14" sink bowl comes with 3 1/2" spout deck mounted 4" O.C. gooseneck faucet 			WH-ECRSPL	Enclosed Rearsplash - FS/DC Series	per lin. ft.
*Table must be 30" or wider to be installed.			WH-ESP	Endsplash - FS/DC Series	per lin. ft.
**Table must be 36" or wider to be installed.			WH-CNRS	Column notch in rearsplash	each
Integrated Double Bowl Welded in Table Top			WH-SP24	Side panel 24" deep	each
WH-PFB2-101410/KIT	10" x 14" x 10" Deep**	each	WH-SP30	Side panel 30" deep	each
WH-PFB2-141612/KIT	14" x 16" x 12" Deep	each	WH-CEO	Cutout for electrical outlet by others - Specify type when ordering.	
WH-PFB2-16208/KIT	16" x 20" x 8" Deep	each	Installation by others. - FS/DC Series Only		
WH-PFB2-162012/KIT	16" x 20" x 12" Deep	each	WH-DUP	Cutout for duplex outlet by others - Specify type when ordering.	
WH-PFB2-181812/KIT	18" x 18" x 12" Deep	each	Installation by others. - FS/DC Series Only		
WH-PFB2-182412/KIT	18" x 24" x 12" Deep	each	WH-HUB	Cutout for Hubble outlet by others - Specify type when ordering.	
WH-PFB2-20208/KIT	20" x 20" x 8" Deep*	each	Installation by others. - FS/DC Series Only		
WH-PFB2-202012/KIT	20" x 20" x 12" Deep*	each	WH-ASBH	Anti. Siphon Vacuum Breaker	each
WH-PFB2-242412/KIT	24" x 24" x 12" Deep**	each	Base Modifications		
WH-OMIT2-FAUCET	Omit Faucet Kit	each	WH-WHCG	Work Height Change	each
<ul style="list-style-type: none"> Double sink bowl comes with 8" Deck Mount 4" O.C Swing Spout Faucet and Basket Drain 10" x 14" sink bowl comes with 3 1/2" swing spout mounted 4" O.C. gooseneck faucet. 			WH-REINF	Reinforced Top or Undershelf	per lin. ft.
*Table must be 30" or wider to be installed.			WH-RMFAP	Removable Front Access Panel	per lin. ft.
**Table must be 36" or wider to be installed.			WH-RBP	Removable Back Panel	each
Edges			WH-DW	Drawer Warmer Ready Slot	each
WH-RE	Rolled Edge	per lin. ft.	WH-INTPART	Interior Partition 2.5"x30"	each
WH-BE	Bullnose Edge	per lin. ft.	WH-REMCP	Removable Kick Plate	per lin. ft.
WH-MARCT	Marine Edge	per lin. ft.	Doors		
WH-MITER	Mitered Edge	per lin. ft.	WH-SLIDDR	Sliding Door	each
WH-MIRROR	Mirrored Edge	per lin. ft.	WH-HGDR	Hinged Door	each
WH-URN	Urn Trough	per lin. ft.	WH-HG24DR	24" Wide Hinged Door	each
Top Cut Outs			WH-PLH	Pad Lock Hasp	each
WH-TCOU36	Top cut out up to 36" length	each	WH-DL	Door Locks	each
WH-TCOO36	Top cut out over 36" length	each	Cut Outs		
WH-RTCO	Round top cut out	each	WH-PCO	12"x12" Cut-Out for Plumbing	each
WH-TRASHCH	Trash Chute	each	WH-URTCO	Undershelf round top cut out	each
WH-NOTTOPT	Notch top for buyout unit	each	WH-GROMMET	2" Hole grommet for appliance cord, specify hole location	each
WH-GROMMET	2" Hole grommet for appliance cord, specify hole location	each	Undershelf		
WH-WELL	Cutout for Cold or Hot Well	each	WH-AJUS	Adjustable undershelf cabinet, base only	per lin. ft.
WH-DISPENSE	Hole for side cup dispenser, dimensions to be provided by dealer for hole	each	WH-USTU	Undershelf 1 1/2" turn up	per lin. ft.
Additional Top Modifications			Leg Accessories		
WH-PASST	Pass-Through Backsplash & Sidesplash	per lin. ft.	4497-3	Flanged stainless steel bullet foot	each
WH-STEPDOWN	Step Down to 24"	each	4471	Stainless steel clad foot	each
WH-PWFJ	Prep Welded Field Joint	each	305SSHBJ-KT4	4 Leg Table, 4 Casters, 2 w/ Locks	each
WH-BFJ	Bolted Field Joint	each	305SSHBJ-KT6	6 Leg Table, 6 Casters, 3 w/ Locks	each
WH-REINF	Reinforced Top or Undershelf	per lin. ft.	WH-LWB	Leg to wall brace	each
WH-SDDEAD	Sound Deadening	per lin. ft.	Overshelves		
Electrical Outlets (no wiring)			WH-OVS10	Overshelf 10" Wide	per lin. ft.
WH-DUPLEX	Duplex Electrical Outlet in Splash	each	WH-OVS12	Overshelf 12" Wide	per lin. ft.
WH-DUPLEXGFI	Duplex Elec. Outlet GFI Specify Location	each	WH-OVS15	Overshelf 15" Wide	per lin. ft.
WH-DUPLEXUND	Duplex Electrical Outlet Under Table Top	each	WH-OVS18	Overshelf 18" Wide	per lin. ft.
WH-DEO	Doghouse Electrical Outlet Box	each	<ul style="list-style-type: none"> All 16 gauge 304 stainless steel includes uprights and hardware. Specify mid mount, rear mount, and splash mount when ordering. 		
WH-HO	Hubble Outlet	each	Pot Racks		
Additional Crating			WH-PRSG	Pot Rack Single	per lin. ft.
WH-CRATE	Complete Crating	per table	WH-PRDO	Pot Rack Double	per lin. ft.
WH-EXPCRATE	Export Crating	per table	<ul style="list-style-type: none"> All 16 gauge 304 stainless steel includes uprights and hardware. Specify mid mount, rear mount, and splash mount when ordering. 		

TABLE MODIFICATIONS

Model Number	Width (in)	Length (in)	Description
Lug & Lug Holder			
ALD-1826	24	32	Lug Holder Slides
WHPL-8-GY	16	25	Gray Lug
Tray Holder			
ALPH-1224	19	24	Holds 18"x26" Pans
Scrap Hole			
416410	Scrap Hole Rectangle 4" x 6"		
416428	Scrap Hole Round 5 3/4" Cut		
416444	Scrap Hole 5 3/4" Cut with Straight Block		
416461	Scrap Hole 5 3/4" Cut with Funnel Block		
Stainless Drawer with Poly Slides			
SD-1 / 24	15	20	Plastic Slide Drawer with SS Front and SS Pan for 24" wide table
SD-1 / 30	20	20	Plastic Slide Drawer with SS Front and SS Pan for 30" wide table
SD-1 / 36	20	20	Plastic Slide Drawer with SS Front and SS Pan for 36" wide table
SD-2	20	20	SS Enclosed Drawer with SS Front and SS Pan
Roller Bearing Slide Drawer			
SD-3RB/24	15	20	Pan for 24" wide table
SD-3RB	20	20	Pan for 30" x 36" wide table
Aluminum Table Mount Style Boat Racks & Dividers			
ALB-48T	15	48	16 lbs
ALB-60T	15	60	18 lbs
ALB-72T	15	72	21 lbs
ALB-96T	15	96	24 lbs
Aluminum Wall Mount Style Boat Racks & Dividers			
ALB-48W	15	48	13 lbs
ALB-60W	15	60	15 lbs
ALB-72W	15	72	18 lbs
ALB-96W	15	96	21 lbs
ALDIV-1218	12	18	Aluminum Divider
Knife Racks & Knife Clips			
KR-14			14
KR-23			23
KR-CLIPS			3/4
Cutting Boards & Replacement Poly Tops See Page 137			

Freight Class: 70



**For Cutting Boards & Replacement Poly Tops
See Page 137**



Poly Top

Lug Holder

Knife Racks

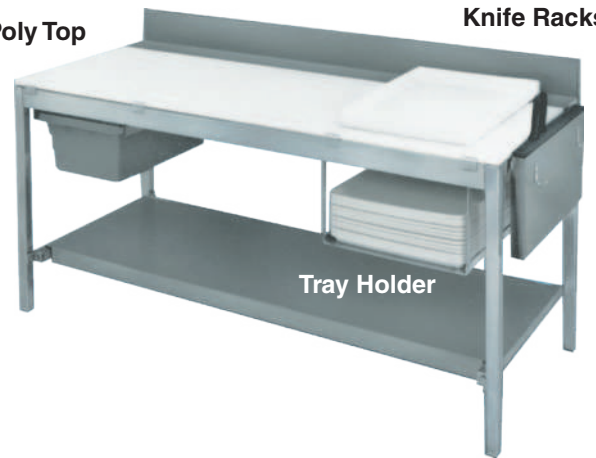

Tray Holder

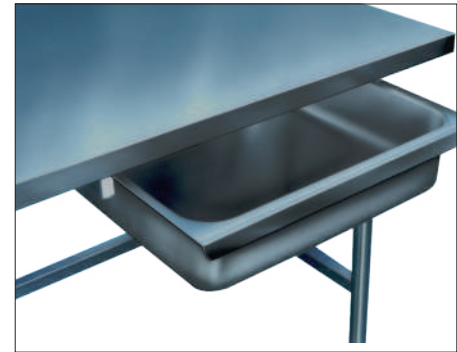

Stainless Steel Drawer SD-1



Slide Draw SDBR-1



Aluminum Table Mounted Boat Rack

WORKSTATION CANTILEVER SHELVING STAINLESS STEEL



Wood Top Table shown with two undershelves and double rear mounted shelves



Pot Rack - Single & Double Splash Mount
Double Shown (WH-PRDO)

WORKSTATION SHELVING STAINLESS STEEL

Length (in)	10" Wide	Wt (lb)	12" Wide	Wt (lb)	15" Wide	Wt (lb)	18" Wide	Wt (lb)
36	WH-COS-1036	9	WH-COS-1236	18	WH-COS-1536	15	WH-COS-1836	30
48	WH-COS-1048	12	WH-COS-1248	24	WH-COS-1548	20	WH-COS-1848	34
60	WH-COS-1060	15	WH-COS-1260	30	WH-COS-1560	25	WH-COS-1860	37
72	WH-COS-1072	18	WH-COS-1272	36	WH-COS-1572	30	WH-COS-1872	46
84	WH-COS-1084	21	WH-COS-1284	42	WH-COS-1584	35	WH-COS-1884	50
96	WH-COS-1096	25	WH-COS-1296	50	WH-COS-1596	40	WH-COS-1896	55

WORKSTATION POT RACKS & UTENSIL RACK

Length (in)	Pot Rack Splashmount	Wt (lb)	Pot Rack Rear Mount	Wt (lb)	Pot Rack Center Mount	Wt (lb)	Utensil Rack	Wt (lb)
36	WH-PRSG-36-SM	30	WH-PRSG-36-RM	30	WH-PRSG-36-CM	30	WH-UR-36	9
48	WH-PRSG-48-SM	34	WH-PRSG-48-RM	34	WH-PRSG-48-CM	34	WH-UR-48	12
60	WH-PRSG-60-SM	37	WH-PRSG-60-RM	37	WH-PRSG-60-CM	37	WH-UR-60	15
72	WH-PRSG-72-SM	46	WH-PRSG-72-RM	46	WH-PRSG-72-CM	46	WH-UR-72	18
84	WH-PRSG-84-SM	50	WH-PRSG-84-RM	50	WH-PRSG-84-CM	50	WH-UR-84	21
96	WH-PRSG-96-SM	55	WH-PRSG-96-RM	55	WH-PRSG-96-CM	55	WH-UR-96	25

SINGLE AND DOUBLE TABLE MOUNTED SHELVES ALL WELDED



- Stainless steel shelf is 300 series 16 gauge undershelf
- Three depths available 10", 12", 15"
- Mounted either front (FM), center (CM), or rear (RM)
- Rear mount (RM) shelves have 1" turn up
- When ordering please specify suffix to the model number.
- **Custom Sizes Available**

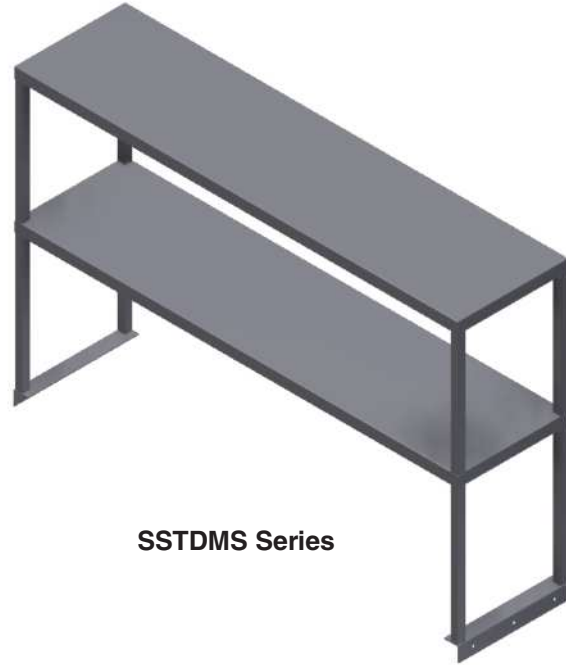

**NOTE: WHEN ORDERING
PLEASE SPECIFY SUFFIX TO THE MODEL NUMBER:**

Example: WH-OVS-S-1584-RM

FM Front Mount

CM Center Mount

RM Rear Mount

SSTDMS Series

Width (in)	Length (in)	Single Overshelf	Wt (lb)	Double Overshelf	Wt (lb)
10	36	SSTMS-1036	9	SSTMDS-1036	18
	48	SSTMS-1048	12	SSTMDS-1048	24
	60	SSTMS-1060	15	SSTMDS-1060	30
	72	SSTMS-1072	18	SSTMDS-1072	36
	84	SSTMS-1084	21	SSTMDS-1084	42
	96	SSTMS-1096	25	SSTMDS-1096	50
12	36	SSTMS-1236	12	SSTMDS-1236	24
	48	SSTMS-1248	16	SSTMDS-1248	32
	60	SSTMS-1260	20	SSTMDS-1260	40
	72	SSTMS-1272	24	SSTMDS-1272	48
	84	SSTMS-1284	28	SSTMDS-1284	56
	96	SSTMS-1296	32	SSTMDS-1296	64
15	36	SSTMS-1536	15	SSTMDS-1536	30
	48	SSTMS-1548	20	SSTMDS-1548	40
	60	SSTMS-1560	25	SSTMDS-1560	50
	72	SSTMS-1572	30	SSTMDS-1572	60
	84	SSTMS-1584	35	SSTMDS-1584	70
	96	SSTMS-1596	40	SSTMDS-1596	80

As part of our commitment to continuous product improvement, Winholt reserves the right to modify materials and specifications without prior notice.

BEVERAGE COUNTERS & DISH CABINETS



BEVERAGE COUNTERS

- Stainless steel top is 300 series 14 gauge with 16 gauge sides
- 10" High backsplash with a 2" return
- Sink is 14" x 16" x 12"D and is available on the Left (L) or Right (R) side
- 1½" basket drain
- Easy access panel to plumbing
- BC-GRS model standard with (3) rack slides for 20" x 20" racks, 8" on centers
- No drip marine edge on 3 sides, urn trough
- 96" or longer units have 6 legs
- GFI Duplex outlet mounted in backsplash
- **Custom Sizes Available**

Size (in)	L x W (in)	Urn Trough Length (in)	Model Number	Model w/ Glass Rack Slides	Wt (lb)
48	48x30	18	STCT-3048-BC-L	STCT-GRS3048-BC-L	230
			STCT-3048-BC-R	STCT-GRS3048-BC-R	
60	60x30	24	STCT-3060-BC-L	STCT-GRS3060-BC-L	250
			STCT-3060-BC-R	STCT-GRS3060-BC-R	
72	72x30	36	STCT-3072-BC-L	STCT-GRS3072-BC-L	270
			STCT-3072-BC-R	STCT-GRS3072-BC-R	
84	84x30	36	STCT-3084-BC-L	STCT-GRS3084-BC-L	290
			STCT-3084-BC-R	STCT-GRS3084-BC-R	
96	96x30	36	STCT-3096-BC-L	STCT-GRS3096-BC-L	330
			STCT-3096-BC-R	STCT-GRS3096-BC-R	

DISH CABINETS

- Stainless steel top is 300 series 14 gauge with 16 gauge sides
- Fixed mid shelf starts at 20" height with 12" spacing
- 35" Height with adjustable feet
- 96" or longer units have 6 legs
- **Custom Sizes Available**

OPTIONS: **WB18** 18" WALL BRACKETS
 All Freight Class: 300

Length (in)	Model 15" Deep	Model 18" Deep	Wt (lb)
48	STCT-1548-DC	STCT-1848-DC	115
60	STCT-1560-DC	STCT-1860-DC	130
72	STCT-1572-DC	STCT-1872-DC	150
84	STCT-1584-DC	STCT-1884-DC	175
96	STCT-1596-DC	STCT-1896-DC	210

HYBRID TABLES

ALL WELDED KNOCK-DOWN DESIGN

EXPRESS
Ships in 2-3 Days!



- Winholt's all welded stainless steel hybrid tables come in standard and custom sizes.
- Our standard line is 300 series stainless steel with 16-gauge tops, 18-gauge legs and undershelves
- All tables come with 3" adjustable feet.
- Fully welded hybrid design ships boxed, saving volume and freight costs
- Patented design with all welded base adds strength and stability
- 300 Series stainless steel construction, includes hat channels, legs and gussets.



**Watch Our
Assembly Video**

Model Number	Order #	Overall Dimensions			Top Wt Capacity	Reinforced Undershef Wt Capacity	Total Wt Capacity	Approx. Ship Wt
		Width	Length	Height				
		(in)	(in)	(in)				
Flat Top & Cross Rails								
DTR-3036-HKD	1148783	30	36	33½	650	-	1050	46
DTR-3048-HKD	1148784	30	48	33½	650	-	1050	55
DTR-3060-HKD	1148785	30	60	33½	650	-	1050	65
DTR-3072-HKD	1148786	30	72	33½	500	-	900	74
Flat Top & Undershef								
DTS-3036-HKD	1148787	30	36	33½	800	400	1200	80
DTS-3048-HKD	1148788	30	48	33½	800	400	1200	87
DTS-3060-HKD	1148789	30	60	33½	800	400	1200	95
DTS-3072-HKD	1148790	30	72	33½	600	400	1000	105
Top w/ Boxed Backsplash & Cross Rails								
DTBB-3036-HKD	1148791	30	36	33½	700	-	1100	53
DTBB-3048-HKD	1148792	30	48	33½	700	-	1100	59
DTBB-3060-HKD	1148793	30	60	33½	700	-	1100	69
DTBB-3072-HKD	1148794	30	72	33½	550	-	950	79
Top w/ Boxed Backsplash & Undershef								
DTSBB-3036-HKD	1148795	30	36	33½	900	400	1300	88
DTSBB-3048-HKD	1148796	30	48	33½	900	400	1300	96
DTSBB-3060-HKD	1148797	30	60	33½	900	400	1300	102
DTSBB-3072-HKD	1148798	30	72	33½	700	400	1100	107



ADJUSTABLE TABLES

- Table height is easily adjusted with a hydraulic lift lever, creating an ergonomic space for workers to comfortably fulfill tasks.
- All welded 16 gauge stainless steel top
- Available with 18 gauge stainless steel under shelving or cross rails
- (1) Hydraulic lift system with foldable crank handle with (4) cylinders that adjust table height 9" from 32" to 41" height in 35 seconds.
- Weight Capacity: 1300 lbs



DTS-3048H32-ADJ-9



UNDERSHELF

Model Number	Order #	Overall Dimensions			Approx. Ship Wt
		Width	Length	Overall Height	
		(in)	(in)	(in)	(lb)
Stainless Steel Top					
DTS-3048H32-ADJ-9	1153870	30	48	32 - 41	140
DTS-3060H32-ADJ-9	1153882	30	60	32 - 41	160
DTS-3072H32-ADJ-9	1153884	30	72	32 - 41	180
Poly Top					
DTS-3048H32-ADJ-9-PT	1153917	30	48	32 - 41	175
DTS-3060H32-ADJ-9-PT	1153918	30	60	32 - 41	200
DTS-3072H32-ADJ-9-PT	1153919	30	72	32 - 41	230

Freight Class: 300

DTS-3048H32-ADJ-9-PT

Watch our Video



CROSS RAILS

Model Number	Order #	Overall Dimensions			Approx. Ship Wt
		Width	Length	Overall Height	
		(in)	(in)	(in)	(lb)
Stainless Steel Top					
DTR-3048H32-ADJ-9	1155333	30	48	32 - 41	125
DTR-3060H32-ADJ-9	1155334	30	60	32 - 41	140
DTR-3072H32-ADJ-9	1155335	30	72	32 - 41	155
Poly Top					
DTR-3048H32-ADJ-9-PT	1155336	30	48	32 - 41	160
DTR-3060H32-ADJ-9-PT	1155337	30	60	32 - 41	180
DTR-3072H32-ADJ-9-PT	1155338	30	72	32 - 41	205

Freight Class: 300

DTS-3048H32-ADJ-9



DTS-3048H32-ADJ-9-PT



FILLER TABLES

- All welded 300 series stainless steel construction, 16 gauge top, 18 gauge legs
- All TIG welded and shipped set up. High polish finish.
- 35" Height with adjustable stainless steel bullet feet
- Legs and cross bracing are 1 5/8" diameter 16 gauge stainless steel tubing
- Stainless steel hat channels deaden sound and reinforce the top to maintain a level work surface.



Width (in)	Length (in)	No Backsplash	1 1/2" Backsplash	Wt (lb)
24	12	DTS-2412	DTSB-15-2412	22
	15	DTS-2415	DTSB-15-2415	31
	18	DTS-2418	DTSB-15-2418	39
30	12	DTS-3012	DTSB-15-3012	25
	15	DTS-3015	DTSB-15-3015	33
	18	DTS-3018	DTSB-15-3018	41
36	12	DTS-3612	DTSB-15-3612	27
	15	DTS-3615	DTSB-15-3615	35
	18	DTS-3618	DTSB-15-3618	43



EQUIPMENT STANDS

- Stainless steel top is 300 series 14 gauge with 16 gauge undershelf
- Work height is 24" high
- Rear and endsplash turned up 2"
- 96" or longer units have 6 legs

Width (in)	Length (in)	Dc Series 14 Gauge	Wt (lb)
24	24	ES-2424-14GA	45
	36	ES-2436-14GA	60
	48	ES-2448-14GA	77
	60	ES-2460-14GA	86
	72	ES-2472-14GA	104
	84	ES-2484-14GA	112
	96	ES-2496-14GA	137
30	24	ES-3024-14GA	51
	36	ES-3036-14GA	68
	48	ES-3048-14GA	85
	60	ES-3060-14GA	102
	72	ES-3072-14GA	119
	84	ES-3084-14GA	142
	96	ES-3096-14GA	164

OPTIONS:

For 16 Gauge top and undershelf remove the -14GA from the model numbers above

-MS2LC 4 legs, 2 with locking casters

-MS6LC 6 legs, 3 with locking casters



EQUIPMENT STAND – MACHINE

- Ideal 24" x 28" top for mixer or grinder
- Convenient 28" height with adjustable stainless steel feet
- Lower shelf for attachment or storage supplies
- All welded 16 gauge stainless steel construction
- Shipped set up
- Weight Capacity: 1000 lbs

Model	Overall Dimensions			Approx. Ship Wt (lb)
	Width	Length	Overall Height	
	(in)	(in)	(in)	
ES-S2428	24	28	28	55



As part of our commitment to continuous product improvement, Winholt reserves the right to modify materials and specifications without prior notice.



ES-MSX3030-14GA

MIXER / SLICER STAND

- Stainless steel top is 300 Series 14 gauge with 16 gauge undershelf
- 24" High with adjustable feet
- 12" Between shelf and table top
- No drip marine edge
- 600 lbs capacity

Width (in)	Length (in)	14 Gauge	Wt (lb)
24	24	ES-MSX2424-14GA	50
	30	ES-MSX2430-14GA	60
30	30	ES-MSX3030-14GA	65
	36	ES-MSX3036-14GA	75
36	36	ES-MSX3636-14GA	83

OPTIONS:

-MS4LC 4 legs, 4 with locking casters

EQUIPMENT STAND - CONVECTION OVEN

- Designed to fit most convection ovens
- Convenient right hand pan slides
- Maneuvers easily on 5" polyurethane casters, two with brakes
- All welded 16 gauge stainless steel construction
- Shipped set up and ready to use



ES-CO3048M

Model	Width (in)	Length (in)	Height (in)	Wt (lb)
ES-CO3048M	30	48	29	175

EQUIPMENT STAND - SCALE

- Ideal for scales in produce and bulk food departments
- Convenient 38" height with adjustable stainless steel feet
- Two lower shelves for storage. Top 16" x 22" surface area.
- 13" between shelves
- Shipped set up and ready to use



ES-S1622

Model	Width (in)	Length (in)	Height (in)	Wt (lb)
ES-S1622	22	16	38	64

All Freight Class: 175



FABRICATED WALL MOUNTED STAINLESS STEEL SHELVES

- All welded 16 gauge stainless steel
- Available in 10", 12" and 15"
- Shelves come with 2 to 4 wall brackets depending on the length
- Custom Sizes Available

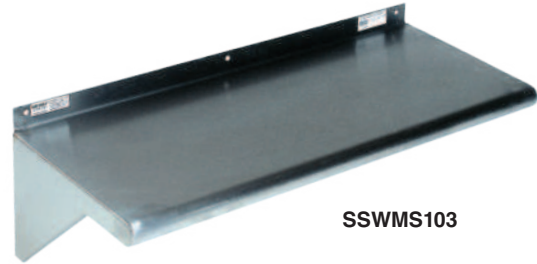

SSWMS103



Length (in)	10" Wide	Wt (lb)	12" Wide	Wt (lb)	15" Wide	Wt (lb)
24	SSWMS102	10	SSWMS122	12	SSWMS152	14
36	SSWMS103	12	SSWMS123	15	SSWMS153	18
48	SSWMS104	14	SSWMS124	18	SSWMS154	22
60	SSWMS105	17	SSWMS125	24	SSWMS155	29
72	SSWMS106	19	SSWMS126	25	SSWMS156	31
84	SSWMS107	22	SSWMS127	29	SSWMS157	36
96	SSWMS108	26	SSWMS128	34	SSWMS158	42

FABRICATED WALL MOUNTED STAINLESS STEEL SHELVES WITH POT HOOKS

- All welded 16 gauge stainless steel
- Available in 10", 12" and 15"
- Shelves come with 2 to 4 wall brackets depending on the length
- Stainless steel pot hooks come standard
- Custom Sizes Available



SSWMSH103

Length (in)	# Of Hooks	10" Wide	Wt (lb)	12" Wide	Wt (lb)	15" Wide	Wt (lb)
24	2	SSWMSH102	10	SSWMSH122	12	SSWMSH152	14
36	3	SSWMSH103	12	SSWMSH123	15	SSWMSH153	18
48	4	SSWMSH104	14	SSWMSH124	18	SSWMSH154	22
60	4	SSWMSH105	17	SSWMSH125	24	SSWMSH155	29
72	6	SSWMSH106	19	SSWMSH126	25	SSWMSH156	31
84	6	SSWMSH07	22	SSWMSH127	29	SSWMSH157	36
96	8	SSWMSH108	26	SSWMSH128	34	SSWMSH158	42

OPTIONS: Extra Hooks (4994)
All Freight Class: 150

SINGLE PASS-THROUGH SHELVES

SSPT-1860



- Stainless steel shelf is 300 series 16 GA
- 18" Wide shelves have 2" x 4" "L" brackets
- 24" Wide shelves have 5" x 5" cantilever brackets
- Custom Sizes Available

Width (in)	Length (in)	Model Number	# Brackets	Wt (lb)
18	48	SSPT-1848	2	14
	60	SSPT-1860	2	17
	72	SSPT-1872	2	19
	84	SSPT-1884	3	22
	96	SSPT-1896	3	26
24	48	SSPT-2448	2	20
	60	SSPT-2460	2	23
	72	SSPT-2472	2	25
	84	SSPT-2484	3	28
	96	SSPT-2496	3	31

Freight Class: 150



STCT-3615-WMO
Open Doors

WALL MOUNT CABINETS

- All welded 16 gauge stainless steel
- Fixed mid-shelf
- 33" High
- Hinged Doors
- Optional lock available

Width (in)	Depth (in)	Open No Doors	Sliding Doors	Hinge Doors	Wt (lb)
36	15	STCT-3615-WMO	-----	STCT-D3615-WMH	115
48	15	STCT-4815-WMO	STCT-D4815-WMS	STCT-D4815-WMH	135
60	15	STCT-6015-WMO	STCT-D6015-WMS	STCT-D6015-WMH	155

Freight Class: 150



MICROWAVE WALL SHELVES

- Stainless steel - 16 Gauge 300 series
- Back is 12" high with pre-drilled holes for wall mounting

Depth (in)	Length (in)	Model Number	Wt (lb)
18	24	SSMS-1824	15
24	24	SSMS-2424	20

Freight Class: 150

WALL MOUNT POT RACKS - STAINLESS STEEL

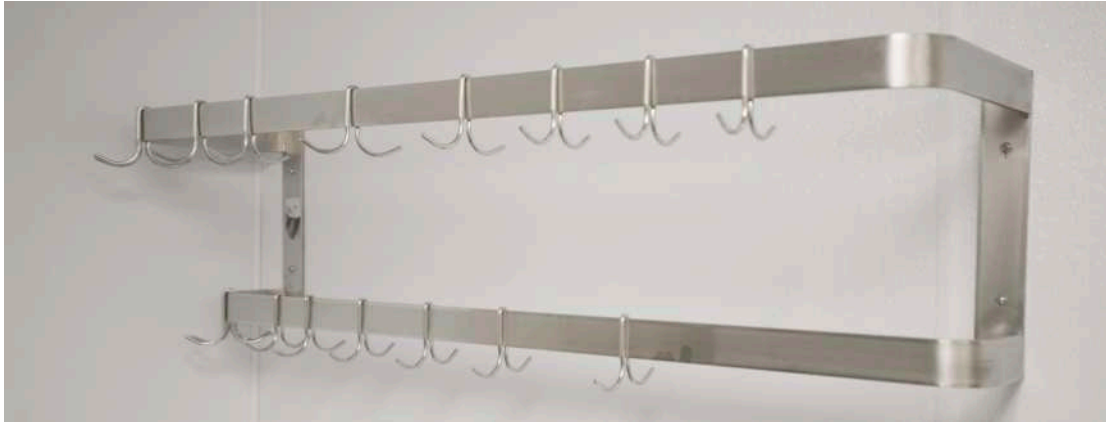

24" Deep Unit With Cantilever Bracket

- All welded 16 gauge stainless steel
- Single and double racks available
- Includes pot hooks
- **Custom Sizes Available**

OPTIONS:
Extra Pot Hooks (4994)

Length (in)	Single Rack	# Pot Hooks	Wt (lb)	Double Rack	# Pot Hooks	Wt (lb)
36	SSWMPR-3016-S	6	4	SSWMPR-3016-D	12	23
48	SSWMPR-4816-S	9	6	SSWMPR-4816-D	18	26
60	SSWMPR-6016-S	9	7	SSWMPR-6016-D	18	29
72	SSWMPR-7216-S	9	8	SSWMPR-7216-D	18	32
84	SSWMPR-8416-S	9	9	SSWMPR-8416-D	18	36
96	SSWMPR-9616-S	9	11	SSWMPR-9616-D	18	44
108	SSWMPR-10816-S	9	13	SSWMPR-10816-D	18	48
120	SSWMPR-12016-S	9	15	SSWMPR-12016-D	18	51
132	SSWMPR-13216-S	9	16	SSWMPR-13216-D	18	55
144	SSWMPR-14416-S	9	18	SSWMPR-14416-D	18	58

Freight Class: 150

CEILING MOUNT POT RACKS STAINLESS STEEL

- Stainless steel - 16 Gauge 300 series with pot hooks.

OPTIONS:
Extra Pot Hooks (4994)

Length (in)	Model Number	# Pot Hooks	Wt (lb)
36	SSCMPR-3016	18	23
48	SSCMPR-4816	18	26
60	SSCMPR-6016	18	29
72	SSCMPR-7216	18	32
84	SSCMPR-8416	18	36
96	SSCMPR-9616	18	44

Freight Class: 150



As part of our commitment to continuous product improvement, Winholt reserves the right to modify materials and specifications without prior notice.

FLOOR TROUGHS



- Durable 14-gauge stainless steel construction
- 4" Deep tub with removable grate for easy cleaning
- 4" Drain and basket for efficient debris capture
- Sleek, industrial design engineered for reliable performance
- Helps prevent pipe clogs and supports a sanitary environment

Model Number	Order #	Overall Dimensions			Approx. Ship Wt
		Width	Length	Height	
		(in)	(in)	(in)	(lb)
FLRTRGH-1224H4-14GA	1155730	12	24	4	34
FLRTRGH-1236H4-14GA	1155731	12	36	4	54
FLRTRGH-1248H4-14GA	1155598	12	48	4	73
FLRTRGH-1260H4-14GA	1155733	12	60	4	90
FLRTRGH-1272H4-14GA	1155734	12	72	4	131
FLRTRGH-1824H4-14GA	1155735	18	24	4	54
FLRTRGH-1836H4-14GA	1155736	18	36	4	77
FLRTRGH-1848H4-14GA	1155737	18	48	4	101
FLRTRGH-1860H4-14GA	1155738	18	60	4	125
FLRTRGH-1872H4-14GA	1155739	18	72	4	176
FLRTRGH-2424H4-14GA	1155740	24	24	4	70
FLRTRGH-2436H4-14GA	1155741	24	36	4	102
FLRTRGH-2448H4-14GA	1155742	24	48	4	132
FLRTRGH-2460H4-14GA	1155743	24	60	4	162
FLRTRGH-2472H4-14GA	1155744	24	72	4	195

Freight Class: 150



FLRTRGH-1248H4-14GA



SS-WF-TRIM-END10

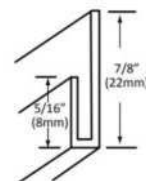

Comes with end trim (shown above) and dividers (shown below) to connect / hold panels



SS-WF-TRIM-DIV10

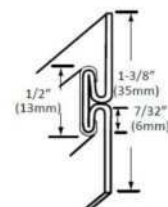

WALL PANELS



Upgrade your kitchen with stainless steel wall paneling. Easy to install using a divider system that allows each panel to slide into place. Perfect as a backsplash for Winholt custom tables and sinks.

- 18 Gauge stainless steel for strength and durability
- Divider system allows panels to slide in for seamless installation
- Easy-to-clean surface reduces maintenance
- Sleek, modern look enhances any workspace
- Long-lasting performance in high-use environments
- Provides seamless integration with other stainless steel fixtures

Model Number	Order #	Width (in)	Length (in)	Wt per Panel (lb)
Stainless Steel Panels				
SSWF-18-36120	1155470	36	120	61
SSWF-18-48120	1155342	48	120	81
SSWF-18-36144	1155471	36	144	73
SSWF-18-48144	1155469	48	144	97

Model Number	Length (in)	Order #
Panel End		
SS-WF-TRIM-END10	120	1150428
Panel Divider		
SS-WF-TRIM-DIV10	120	1150427

Model Number	Length (in)	Order #
Inside Corner		
SS-WF-CNR-IN10	120	1156212
Outside Corner		
SS-WF-CNR-OUT10	120	1156213



HEATER PROOFERS & CABINETS

Pass-Through Heater Proofer

Universal Heater Proofers

Non-Insulated Heater Proofers

Standard

Economy

1/2 Height Under the Counter

Insulated Heater Proofers

Enclosed Mobile Transport Cabinets

Watch our Video





INHPL-2416-PBCAB-DGT

HEATER PROOFER INSULATED PASS-THROUGH 100% PRE-TESTED ELECTRICAL ASSEMBLY

- Insulated, heavy duty aluminum construction
- Forced air design provides even heat distribution.
- (4) Removable wire chrome pan slides for variable spacing and easy cleaning.
- 3" Runner Spacing
- 5" Polyurethane plate casters for easy maneuverability and stability. Front casters are provided with brakes.
- Easy to read digital dual proof/heat control
- "Proof/Humidity" Mode: Up to 95% RH at 110°F (43°C)
- "Heat" Mode: Maximum Temperatures up to 180°F (82°C)
- (2) Pass-Through Field Reversible Doors open 270°. Removable for easy cleaning and accessibility. Magnetic door latch to keep doors closed during transport.
- Digital control drawer is removable for quick and easy cleaning and maintenance.
- Internal water pan collects condensation or is used in proofer mode.
- All controls are accessible without opening cabinet door.
- Pan Capacity: (16) 18" x 26", 24" x 24", or 20" x 12" pans and to-go boxes
- Corner bumpers provide protection to unit, associates and fixtures.
- Keep food warm while standing for delivery & mobile order pickup.
- Extra width specifically designed to accommodate large pizza boxes (up to 24")
- Easily and efficiently proof up to 16 pans of dough. Perfect for producing large quantities of dough in commercial, QSR and standard kitchens.

Electrical specifications:

- 120 Volt-60 Hz, NEMA 5-15P
- 1440 Watts: 14.0 AMPS - Plug into any standard 110V outlet.

Perfect for Pizzerias



and Donut Shops!



Model Number	Order #	Overall Dimensions			Approx. Ship Wt (lb)
		Width (in)	Length (in)	Height (in)	
INHPL-2416-PBCAB-DGT	1152216	30½	33¾	66½	154

Caster Information:

Swivel Plate Caster with 5" Polyurethane Wheel 738A (128784)
Swivel Plate Caster with 5" Polyurethane Wheel & Brake 738ABK (204185)
5" Polyurethane Wheel 7112 (122180)

Freight Class: 250



HEATER PROOFERS - INSULATED UNIVERSAL RUNNER 100% PRE-TESTED ELECTRICAL ASSEMBLY

- Heavy duty aluminum construction designed for durability.
- Easy to clean.
- Forced air design provides even heat distribution.
- 5" Polyurethane plate casters for easy maneuverability and stability. Front casters are provided with brakes.
- Easy dual proof/heat control: Available in Digital (DGT) and Analog Design
- "Proof/Humidity" Mode: Up to 95% RH at 110°F (43°C)
- "Heat" Mode: Maximum Temperatures up to 180°F (82°C)
- Corner bumpers provide protection to unit, associates & fixtures.
- Clear door, extruded, powder coated aluminum frame will not dull. A tight fit gasket is installed on the inside door frame.
- Field Reversible Door opens 270° - Lifts off for cleaning and accessibility.
- Control drawer is removable for quick and easy cleaning and maintenance.
- Internal water pan collects condensation or is used in proofer mode.
- All controls are accessible without opening cabinet door.
- Pan Capacity: (25) 18" x 26" pans

Electrical specifications:

- 120 Volt-60 Hz, NEMA 5-15P
- 1440 Watts: 14.0 AMPS - Plug into any standard 110V outlet.

Model Number	Order #	Overall Dimensions			Approx. Ship Wt (lb)
		Width (in)	Length (in)	Height (in)	
Digital Drawer					
INHPL-1825-UNC-DGT	1148063	23⁴/₅	32	70	154
Analog Drawer					
INHPL-1825-UNC	1148047	23⁴/₅	32	70	154

Caster Information:

Swivel Plate Caster with 5" Polyurethane Wheel 738A (128784)
Swivel Plate Caster with 5" Polyurethane Wheel & Brake 738ABK (204185)
5" Polyurethane Wheel 7112 (122180)

Freight Class: 250



EXPRESS
Ships in 2-3 Days!



INHPL-1825-UNC-DGT



**Adjustable
Universal Runners**



**Magnetic Door
Latch**



**Field Reversible
Door Mount**

As part of our commitment to continuous product improvement, Winholt reserves the right to modify materials and specifications without prior notice.

800.444.3595 | sales@winholt.com | www.winholt.com





NHPL-1825-UNC-DGT

Options: Additional runner slides (52) pieces per box
 NHPL-1825-UN-Runner (657150)



HEATER PROOFERS - NON-INSULATED UNIVERSAL RUNNER

100% PRE-TESTED ELECTRICAL ASSEMBLY

- Heavy duty aluminum construction designed for durability.
- Easy to clean.
- Forced air design provides even heat distribution.
- 5" Polyurethane plate casters for easy maneuverability and stability. Front casters are provided with brakes.
- Easy dual proof/heat control: Available in Digital (DGT) and Analog Design
- "Proof/Humidity" Mode: Up to 95% RH at 110°F (43°C)
- "Heat" Mode: Maximum Temperatures up to 180°F (82°C)
- Corner bumpers provide protection to unit, associates & fixtures.
- Clear door, extruded, powder coated aluminum frame will not dull. A tight fit gasket is installed on the inside door frame.
- Field Reversible Door opens 270° - Lifts off for cleaning and accessibility.
- Control drawer is removable for quick and easy cleaning and maintenance.
- Internal water pan collects condensation or is used in proofer mode.
- All controls are accessible without opening cabinet door.
- Pan Capacity: (25) 18" x 26" pans

Electrical specifications:

- 120 Volt-60 Hz, NEMA 5-15P
- 1440 Watts: 14.0 AMPS - Plug into any standard 110V outlet.

Model Number	Order #	Overall Dimensions			Approx. Ship Wt (lb)
		Width (in)	Length (in)	Height (in)	
Digital Drawer					
NHPL-1825-UNC-DGT	1078993	22 ³ / ₁₀	33 ¹ / ₅	70 ¹ / ₁₀	162 ¹ / ₂
Analog Drawer					
NHPL-1825-UNC	684641	22 ³ / ₁₀	33 ¹ / ₅	70 ¹ / ₁₀	162 ¹ / ₂

Caster Information:

Swivel Plate Caster with 5" Polyurethane Wheel 738A (128784)
 Swivel Plate Caster with 5" Polyurethane Wheel & Brake 738ABK (204185)
 5" Polyurethane Wheel 7112 (122180)
 Freight Class: 250

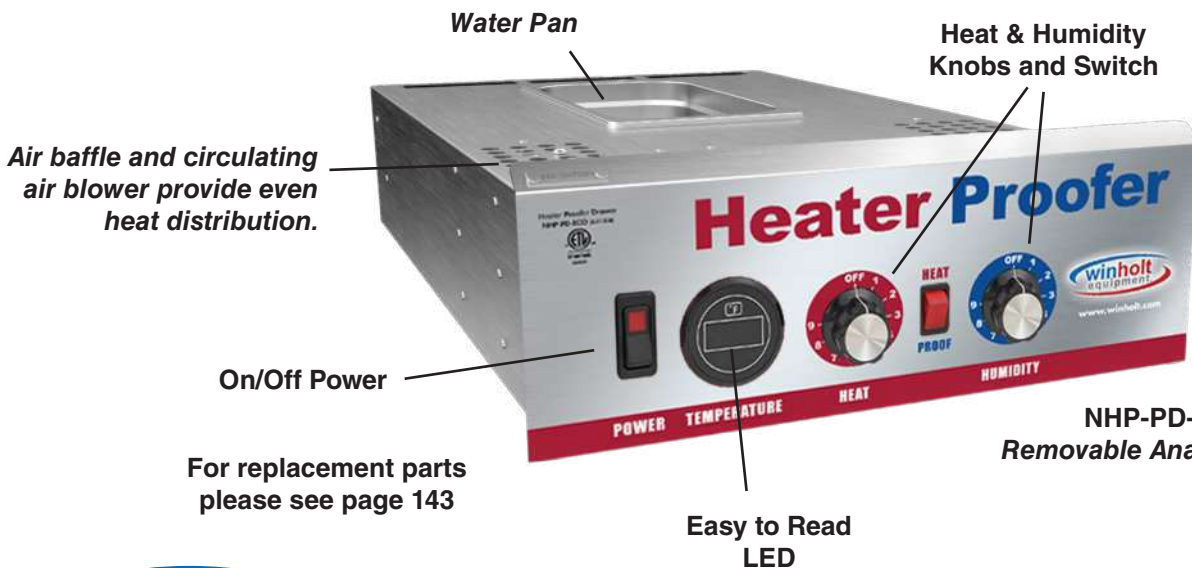

For replacement parts please see page 143

HEATER PROOFERS NON-INSULATED STANDARD FULL, ECONOMY & 1/2 HEIGHT POLY TOP 100% PRE-TESTED ELECTRICAL ASSEMBLY

- Heavy duty aluminum construction designed for durability.
- Easy to clean.
- Forced air design provides even heat distribution.
- 5" Polyurethane plate casters for easy maneuverability and stability. Front casters are provided with brakes.
- Easy dual proof/heat control
- "Proof/Humidity" Mode: Up to 95% humidity at 110°F (43°C)
- "Heat" Mode: Maximum Temperatures up to 180°F (82°C)
- Corner bumpers provide protection to unit, associates & fixtures.
- Clear door, extruded, powder coated aluminum frame will not dull. A tight fit gasket is installed on the inside door frame.
- Half height model has a poly top.
- Field Reversible Door opens 270° - Lifts off for cleaning and accessibility.
- Control drawer is removable for quick and easy cleaning and maintenance.
- Internal water pan collects condensation or is used in proofer mode.
- All controls are accessible without opening cabinet door.
- Pan Capacity: (35) 18" x 26" pans NHPL-1836C-DGT & NHPL-1836-ECOC
(10) 18" x 26" pans NHPL-1810HHC

Electrical specifications:

- 120 Volt - 60 Hz, NEMA 5-15P
- 1440 Watts: 14.0 AMPS - Plug into any standard 110V outlet.

Model Number	Order #	Overall Dimensions			Approx. Ship Wt
		Width	Length	Height	
		(in)	(in)	(in)	(lb)
Digital Drawer - Standard Full					
NHPL-1836C-DGT	1078985	21	32¾	66½	136
Analog Drawer - Economy					
NHPL-1836-ECOC	1146932	20¾	33¾	66¾	136
Analog Drawer - ½ Height					
NHPL-1810HHC	684625	22⅞	32¾	30½	100

Caster Information:

Swivel Plate Caster with 5" Polyurethane Wheel 738A (128784)
Swivel Plate Caster with 5" Polyurethane Wheel & Brake 738ABK (204185)
5" Polyurethane Wheel 7112 (122180)

Freight Class: 250

EXPRESS
Ships in 2-3 Days!



NHPL-1836C-DGT



NHPL-1810HHC
Fits under counters
and tables.

HEATER PROOFERS - INSULATED

35% ENERGY SAVINGS!

100% PRE-TESTED ELECTRICAL ASSEMBLY



INHPL-1836C-DGT

- Heavy duty aluminum construction designed for durability.
- Easy to clean.
- Forced air design provides even heat distribution.
- 5" Polyurethane plate casters for easy maneuverability and stability. Front casters are provided with brakes.
- Easy dual proof/heat control: Available in Digital (DGT) and Analog Design
- "Proof/Humidity" Mode: Up to 95% RH at 110°F (43°C)
- "Heat" Mode: Maximum Temperatures up to 180°F (82°C)
- Corner bumpers provide protection to unit, associates & fixtures.
- Clear door, extruded, powder coated aluminum frame will not dull. A tight fit gasket is installed on the inside door frame.
- Field Reversible Door opens 270° - Lifts off for cleaning and accessibility.
- Control drawer is removable for quick and easy cleaning and maintenance.
- Internal water pan collects condensation or is used in proofer mode.
- All controls are accessible without opening cabinet door.
- Pan Capacity: (35) 18" x 26" pans

Electrical specifications:

- 120 Volt-60 Hz, NEMA 5-15P
- 1440 Watts: 14.0 AMPS - Plug into any standard 110V outlet.

Model Number	Order #	Overall Dimensions			Approx. Ship Wt (lb)
		Width (in)	Length (in)	Height (in)	
Digital Drawer					
INHPL-1836C-DGT	1079013	20¾	34 ¹ / ₈	67 ¹ / ₈	154
Analog Drawer					
INHPL-1836C	684609	20¾	34 ¹ / ₈	67 ¹ / ₈	154

Caster Information:

Swivel Plate Caster with 5" Polyurethane Wheel 738A (128784)
 Swivel Plate Caster with 5" Polyurethane Wheel & Brake 738ABK (204185)
 5" Polyurethane Wheel 7112 (122180)
Freight Class: 250

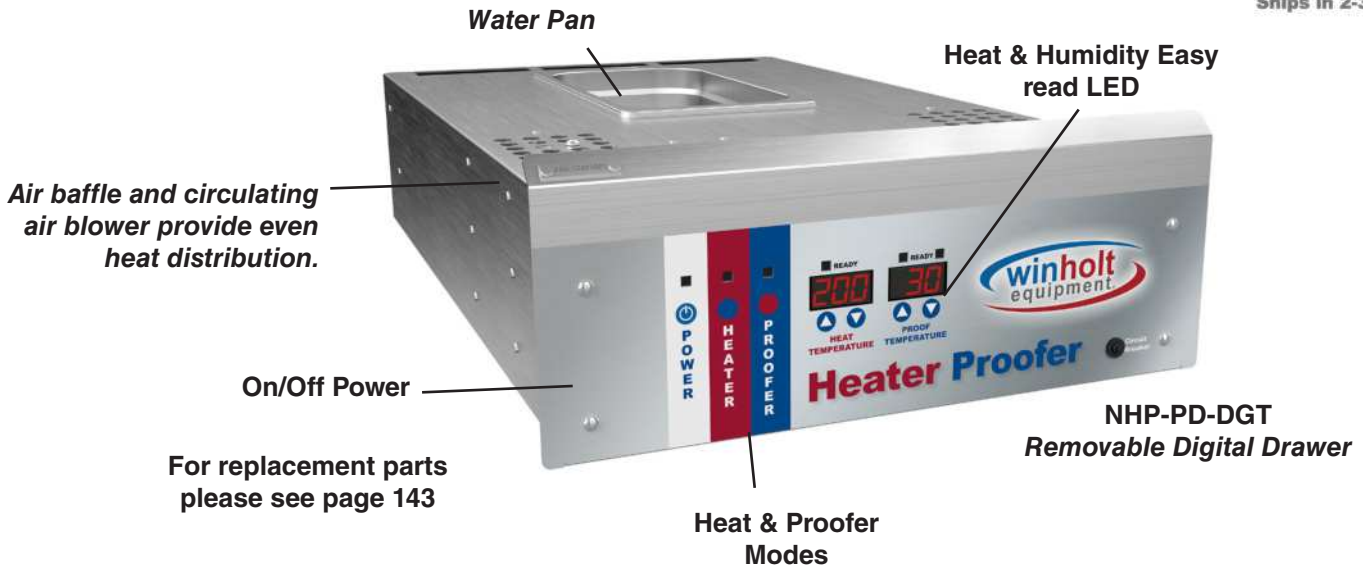

ENCLOSED MOBILE TRANSPORT CABINETS

- Stores and transport goods, prevents dehydration
- All welded, reinforced, non-insulated aluminum. Sanitary and rustproof.
- Double pan construction with reinforced braces, 1½" spacing between runners
- Door opens 270°
- Weight Capacity per Runner: 20 lbs
- Easily maneuverable on (4) 5" polyurethane, swivel plate, double ball race casters. Locking casters are available.

Model Number	Order #	Overall Dimensions			Pan Cap.	Approx. Ship Wt
		Width	Length	Height		
		(in)	(in)	(in)	18" x 26"	(lb)
EC1816-C	110795	21	27	32	16	57
EC1824-C	110824			44	24	70
EC1832-C	110832			56	32	84
EC1840-C	110841			68	40	94
Clear Acrylic Door						
EC1840-C-LD	150375	21	27	68	40	115

Caster Information:
 Swivel Plate Caster with 5" Polyurethane Wheel 738A (128784)
 5" Polyurethane Wheel 7112 (122180)
Freight Class: 175

Options:
PP Prison Package - is designed for correctional institutions with tamper resistant hardware
B Bumpers - (4) Corner bumpers
LC Locking Casters - (4) locking casters
LD Lexan Door - Clear acrylic door



EC1840-C

MODEL EC1816-C
 21" W x 27" L x 32"
 Pan Capacity:
 (16) 18" x 26" Trays



MODEL EC1824-C
 21" W x 27" L x 44"
 Pan Capacity:
 (24) 18" x 26" Trays



MODEL EC1832-C
 21" W x 27" L x 56"
 Pan Capacity:
 (32) 18" x 26" Trays



MODEL EC1840-C-LD
 21" W x 27" L x 68" H
 Pan Capacity:
 (40) 18" x 26" Trays



As part of our commitment to continuous product improvement, Winholt reserves the right to modify materials and specifications without prior notice.

800.444.3595 | sales@winholt.com | www.winholt.com



ENCLOSED MOBILE TRANSPORT CABINETS HEAVY DUTY



EC-1840-CTLPURC

- Stores and transport goods, prevents dehydration
- Constructed of all welded, reinforced, non-insulated aluminum. Sanitary and rustproof.
- Double pan top construction with reinforced brace, 1½” spacing between runners.
- Heavy duty, reinforced hinges and latch assure easy closing with a secure fit.
- Maneuvers easily on 5” polyurethane, swivel plate, double ball race casters.

Model Number	Order #	Overall Dimensions			Pan Cap 18" x 26"	Approx. Ship Wt (lb)
		Width (in)	Length (in)	Height (in)		
Heavy Duty Enclosed Cabinet with Reinforced Undercarriage						
EC1840-CTL	110859	21	27 ³ / ₈	67 ³ / ₄	40	115
Extra Heavy Duty Enclosed Cabinet with Reinforced Undercarriage and Frame						
EC1832-CTLPURC	150383	21	27	56	32	115
EC1840-CTLPURC	110904			68	40	120

Caster Information for Model EC-1840-CTL:
(4) 5" x 2" Swivel Plate Casters (7318)

Caster Information for Models EC-1832-CTLPURC & EC-1840-CTLPURC:
(4) 5" x 1½" Swivel Plate Casters (738)

All Freight Class: 150

Options:

PP Prison Package - is designed for correctional institutions with tamper resistant hardware.

B Bumpers - (4) Corner bumpers

LC Locking Casters - (4) locking casters



Heavy duty, reinforced, galvanized steel undercarriage, provides extra strength support.



If you need an enclosed cabinet designed and manufactured to meet your exact specifications, please contact us at sales@winholt.com



FOODSERVICE RACKS & MOBILE STORAGE

- Knock-Down Pan Racks
- Medium Duty Pan Racks
- Heavy Duty Pan Racks
- Xtra Heavy Duty Pan Racks
- Half Size Pan Racks
- Universal Pan Racks
- Roll-In Refrigerator Pan Racks
- Channel Pan Racks
- Wire Pan Racks
- Nesting Racks
- Stainless Steel Pan Racks
- Can Racks
- Steam Table Racks
- Pizza Pan Rack
- Donut Screen Racks
- Oven Racks
- Reach-In Refrigerator Racks
- Double Pan Rack
- Slanted Rack
- Queen Mary Banquet Carts
- Stainless Steel Utility Carts
- Grab & Go Merchandiser Carts
- Chicken Breeding Work Station
- Mobile Landing Table
- Ingredient Bins
- Rotisserie Storage Transport Rack
- Sheet Pan Trucks
- Dollies
- Flat Bed Carts

Watch our Video





ADE1820B-KDA
Economy

KNOCK-DOWN PAN RACKS

- Material: Aluminum, all welded 1" tubing. Runner Angle: 1" x 1½"
- **Lifetime Warranty Against Rust**
- Application: Proof, store and transport full and half size sheet pans.
- Ships knock-down, saving on freight
- Holds:
 - 18" x 26" Sheet Pans
 - 14" x 18" Sheet Pans
- Casters: 5" Polyolefin Swivel Stem
- Rolling Capacity: 600 lbs
- Weight Capacity per Runner: 20 lbs



AL-1820BKD-HD
Heavy Duty

Model Number	Order #	Overall Dimensions			Pan Cap.	Runner Spacing	Approx. Ship Wt
		Width	Length	Height			
		(in)	(in)	(in)	18" x 26" 14" x 18"	(in)	(lb)
ADE1820B-KDA	112168	21	26	70	20 40	3	30
AL-1820BKD-HD	323459	21	26	70	20 40	3	42

Caster Information:
Caster with 5" Polyolefin Wheel 751 (123588)
5" Polyolefin Wheel 717 (122681)
Freight Class: 175

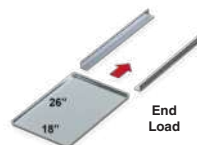

MEDIUM DUTY PAN RACKS - END LOAD

- Material: Aluminum, all welded. Runner Angle: 1" x 1½"
- **Lifetime Warranty Against Rust**
- Application: Proof, store and transport finished product. Holds full size and half size sheet pans.
- Holds:
 - 18" x 26" Sheet Pans
 - 14" x 18" Sheet Pans
- Casters: 5" Polyurethane Swivel Stem
- Rolling Capacity: 800 lbs
- Weight Capacity per Runner: 30 lbs



AL-1812B

Model Number	Order #	Overall Dimensions			Pan Cap.	Runner Spacing	Approx. Ship Wt
		Width	Length	Height			
		(in)	(in)	(in)	18" x 26" 14" x 18"	(in)	(lb)
AL-1810B	109840	21	26	69¾	10 20	6	29
AL-1812B	109882	21	26	69¾	12 24	5	25
AL-1815B	109938	21	26	69¾	15 30	4	28
AL-1818B	109989	21	26	69¾	18 36	3	30
AL-1820B	110023	21	26	69¾	20 40	3	35
AL-1830B	110120	21	26	69¾	30 60	2	44

Caster Information:
Caster with 5" Polyurethane Wheel 757 (123684)
5" Polyurethane Wheel 7112 (122180)
Freight Class: 250

- Options:**
- B** Bumpers (4)
 - BP** Plate Casters 5" Polyurethane Wheel
 - LC** Locking Casters
 - TG-AL** Tray Guard/Aluminum
 - SB** Aluminum Solid Bottom
 - PP** Prison Package
 - XB** XHD Reinforced Uprights



MEDIUM DUTY PAN RACKS – SIDE LOAD

- Material: Aluminum, all welded. Runner Angle: 1" x 1½"
- **Lifetime Warranty Against Rust**
- Application: Proof, store and transport finished product. Holds full size sheet pans, loading on the 26" side.
- Holds: 18" x 26" Sheet Pans
- Casters: 5" Polyurethane Swivel Stem
- Rolling Capacity: 800 lbs
- Weight Capacity per Runner: 30 lbs

Model Number	Order #	Overall Dimensions			Pan Cap.	Runner Spacing	Approx. Ship Wt
		Width	Length	Height			
		(in)	(in)	(in)			
AL-2610B	110251	28	18	69¾	10	6	27
AL-2612B	110269	28	18	69¾	12	5	35
AL-2615B	110293	28	18	69¾	15	4	37
AL-2618B	110322	28	18	69¾	18	3	38
AL-2620B	110349	28	18	69¾	20	3	32

Caster Information:
 Caster with 5" Polyurethane Wheel 757 (123684)
 5" Polyurethane Wheel 7112 (122180)
Freight Class: 250

Options:

- B** Bumpers (4)
- BP** Plate Casters 5" Polyurethane Wheel
- LC** Locking Casters
- TG-AL** Tray Guard/Aluminum
- SB** Aluminum Solid Bottom
- PP** Prison Package
- XB** XHD Reinforced Uprights

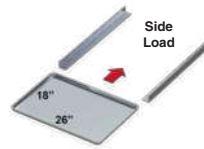

HEAVY DUTY PAN RACK – END LOAD

- Material: Aluminum, all welded 1" tubing. Runner Angle: 1" x 1½"
- **Lifetime Warranty Against Rust**
- Application: Heavy duty rack proof, store and transport full size sheet pans or half size sheet pans. Ideal for schools, restaurants, catering, banquet halls.
- Holds: 18" x 26" Sheet Pans
14" x 18" Sheet Pans
- Casters: 5" Polyurethane Swivel Stem
- Rolling Capacity: 800 lbs
- Weight Capacity per Runner: 60 lbs

Model Number	Order #	Overall Dimensions			Pan Cap.	Runner Spacing	Approx. Ship Wt
		Width	Length	Height			
		(in)	(in)	(in)			
AL-1820B-XB	647023	21	26	69¾	20	3	48

Caster Information:
 Caster with 5" Polyurethane Wheel 757 (123684)
 5" Polyurethane Wheel 7112 (122180)
Freight Class: 250

Options:

- B** Bumpers (4)
- BP** Plate Casters 5" Polyurethane Wheel
- LC** Locking Casters
- TG-AL** Tray Guard/Aluminum
- SB** Aluminum Solid Bottom
- PP** Prison Package
- SB** Aluminum Solid Bottom
- PP** Prison Package



As part of our commitment to continuous product improvement, Winholt reserves the right to modify materials and specifications without prior notice.



AL-1820-HD

XTRA HEAVY DUTY PAN RACK – END LOAD

- Material: Aluminum, all welded 1½” tubing. Runner Angle: 1¼” x 2”
- **Lifetime Construction Warranty & Lifetime Warranty Against Rust**
Excludes Casters & Fasteners
- Application: Heavy duty rack for use in correctionals, catering, schools and commissaries.
- Holds:
 - 18” x 26” Sheet Pans
 - 14” x 18” Sheet Pans
- Tubing 1½”
- Casters: 5 x 2” Polyurethane Swivel Plate, (2) with locks
- Rolling Capacity: 1000 lbs
- Weight Capacity per Runner: 80 lbs

Model Number	Order #	Pan Cap. 18” x 26” 14” x 18”	Dimensions			Runner Spacing (in)	Approx. Ship Wt (lb)
			Width	Length	Height		
			(in)	(in)	(in)		
AL-1812-HD	592536	12 24	21½	26	71½	5	50
AL-1820-HD	592165	20 40	21½	26	71½	3	50
AL-1830-HD	592173	30 60	21½	26	71½	2	50

Caster Information:
Caster with 5” x 2”
Polyurethane Wheel 7318
(123051)
Freight Class: 250



- Options:**
- ST Solid Top
 - SB Solid Base
 - PEB Perimeter Bumpers
 - LB “L” Shape Bumpers
 - VB Vertical Bumpers (12”)
 - PP Prison Package



AL-1810-H

HALF SIZE PAN RACKS – END LOAD



- Material: Aluminum, all welded 1” tubing. Runner Angle: 1” x 1½”
- **Lifetime Warranty Against Rust**
- Application: Designed for low volume locations that do not need a full size rack. Work top available in aluminum, stainless steel or poly top.
- Holds:
 - 18” x 26” Sheet Pans
 - 14” x 18” Sheet Pans
- Casters: 5” Polyurethane Swivel Stem
- Rolling Capacity: 800 lbs
- Weight Capacity per Runner: 30 lbs

Model Number	Order #	Overall Dimensions			Pan Cap. 18” x 26” 14” x 18”	Runner Spacing (in)	Approx. Ship Wt (lb)
		Width	Length	Height			
		(in)	(in)	(in)			
Open Top							
AL-1806-H	206797	21	26	38 ^{2/5}	6 12	5	23
AL-1810-H	206800	21	26	38 ^{2/5}	10 20	3	29
Aluminum Top							
AL-1806H-ALTOP	1081367	21	26	40 ^{3/5}	6 12	5	31
AL-1810H-ALTOP	625941	21	26	40 ^{3/5}	10 20	3	34
Stainless Steel Top							
AL-1806H-SSTOP	1022800	21	26	40 ^{3/5}	6 12	5	31
AL-1810H-SSTOP	537676	21	26	40 ^{3/5}	10 20	3	31
Poly Top - Removable							
AL-1810-H-PT	567488	21	26	38	10 20	3	29

Caster Information:
Caster with 5” Polyurethane Wheel
757 (123684)
5” Polyurethane Wheel 7112
(122180)
Freight Class: 250

- Options:**
- B Bumpers (4)
 - BP Plate Casters
 - LC Locking Casters
 - TG-AL Tray Guard/Aluminum
 - SB Aluminum Solid Bottom
 - PP Prison Package
 - XB XHD Reinforced Upright



AL-1810H-SSTOP

MEDIUM DUTY UNIVERSAL RUNNER RACK

- Material: All welded aluminum. Runner Angle: 1¼" x 3⅓"
- Lifetime Warranty Against Rust**
- Application: Medium duty universal pan rack for holding steam table pans and sheet pans.
- Model UARE-1818-64H-4CB has (4) corner bumpers.
- Holds:
 - 18" x 26" Sheet Pans
 - 14" x 18" Sheet Pans
 - Full, Half, ⅓ Size Steam Pans (held by the lip)
- Casters: 5" Polyurethane Swivel Stem
- Rolling Capacity: 800 lbs
- Weight Capacity per Runner: 30 lbs

Model Number	Order #	Overall Dimensions			Pan Cap. 18" x 26" 14" x 18"	Runner Spacing (in)	Approx. Ship Wt (lb)
		Width	Length	Height			
		(in)	(in)	(in)			
UARE-1218	389212	21	26	70	12 24	5	32
UARE-2018	389221	21	26	70	20 40	3	54
UARE-1818-64H-4CB	1064840	22½	26	64⅜	18 36	3	40

Caster Information:
Caster with 5" Polyurethane Wheel 757 (123684)
5" Polyolefin Wheel 7112 (122180)
Freight Class: 250

Options:
XB XHD Reinforced Upright

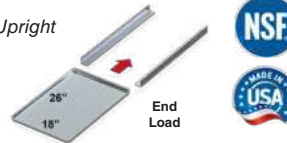

UARE-2018

XTRA HEAVY DUTY UNIVERSAL RUNNER RACK

- Material: All welded aluminum construction, tubing: 1½", Runner Angle: 1¼" x 3¼"
- Lifetime Construction Warranty & Lifetime Warranty Against Rust**
Excludes Casters & Fasteners
- Application: For holding steam table pans and sheet pans.
- Holds:
 - 18" x 26" Sheet Pans
 - 14" x 18" Sheet Pans
 - Full, Half, ⅓ Size Steam Pans (held by the lip)
- Casters: 5" x 2" Polyurethane Plate
- Rolling Capacity: 800 lbs
- Weight Capacity per Runner: 80 lbs

Model Number	Order #	Pan Cap.			Dimensions			Runner Spacing (in)	Approx. Ship Wt (lb)
		18" x 26"	12" x 20"	14" x 18"	Width	Length	Height		
		(in)	(in)	(in)	(in)	(in)	(in)		
ALUN-1812-HD	592552	12	11	24	21½	26	71½	5	48
ALUN-1820-HD	592544	20	19	40	21½	26	71½	3	50

Caster Information:
Caster with 5" x 2" Polyurethane Wheel 7318 (123051)
Freight Class: 250

- Options:**
- ST Solid Top
 - SB Solid Base
 - PEB Perimeter Bumpers
 - LB "L" Shape Bumpers
 - VB Vertical Bumpers (12")
 - PP Prison Package

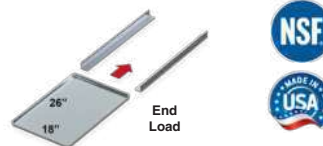

ALUN-1820-HD



UAR-1023

MEDIUM DUTY UNIVERSAL WIDE RUNNER RACKS

- Material: All welded aluminum 1¼" tubing.
Runner Angle: 1¼" x 6⅛"
- **Lifetime Warranty Against Rust**
- Application: Economy rack for holding steam table pans and sheet pans.
- Casters: 5 x 2" Polyurethane Plate
- Holds:
 - 18" x 26" Sheet Pans
 - 14" x 18" Sheet Pans
 - Full, Half, ⅓ Size Steam Pans (held by the bottom)
- Rolling Capacity: 800 lbs
- Weight Capacity per Runner: 60 lbs

Model Number	Order #	Overall Dimensions			Pan Cap. All Sizes	Runner Spacing	Approx. Ship Wt
		Width	Length	Height			
		(in)	(in)	(in)		(in)	(lb)
UAR-1023	389124	26	27	72 ¹ / ₅	10	6	70
UAR-1223	389141	26	27	72 ¹ / ₅	12	5	78
UAR-2023	389167	26	27	72 ¹ / ₅	20	3	110

Caster Information:
Caster with 5" Polyurethane Wheel 738AW (523039)
5" Polyurethane Wheel 7112 (122180)
Freight Class: 250

Options:
XB XHD Reinforced Upright

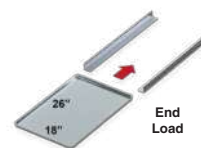

ROLL-IN REFRIGERATOR RACKS



ALREF-1818-64E

- Material: All welded aluminum 1" tubing.
Runner Angle: 1¼"
- **Lifetime Warranty Against Rust**
- Application: Designed for roll-in refrigerators and freezers.
- Holds:
 - 18" x 26" Sheet Pans
 - 14" x 18" Sheet Pans
- Casters: Polyurethane Swivel Plate
- Rolling Capacity: 800 lbs
- Weight Capacity per Runner: 30 lbs

Model Number	Order #	Overall Dimensions			Pan Cap. 18" x 26" 14" x 18"	Runner Spacing	Approx. Ship Wt
		Width	Length	Height			
		(in)	(in)	(in)		(in)	(lb)
ALREF-1118-64E	384956	20 ⁷ / ₈	26	64 ⁴ / ₅	11 22	5	40
ALREF-1818-64E	384981	20 ⁷ / ₈	26	64 ⁴ / ₅	18 36	3	53

Caster Information:
Caster with 5" Polyurethane Wheel 738AW (523039)
5" Polyurethane Wheel 7112 (122180)
Freight Class: 250

Options:
XB XHD Reinforced Upright

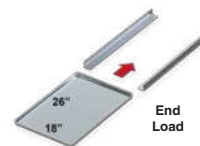

CHANNEL PAN RACKS

- Material: All welded aluminum, C-Channel is 1½" x 1" with a lip of 5/8"
- **Lifetime Warranty Against Rust**
- Application: Designed for maximum storage capacity in bakeries, restaurants, industrial areas where high and low profile products are stored.
- Holds:
18" x 26" Sheet Pans by lip
14" x 18" Sheet Pans by lip
- Casters: 5" Polyurethane Swivel Stem

- Rolling Capacity: 800 lbs
- Weight Capacity per Runner: 30 lbs

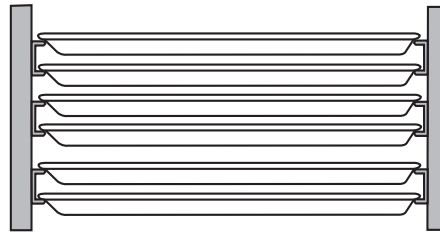

C-Channel holds lip of tray



ALC-1836

Model Number	Order #	Overall Dimensions			Pan Cap. 18" x 26" 14" x 18"	Runner Spacing	Approx. Ship Wt
		Width	Length	Height			
		(in)	(in)	(in)	(in)		
ALC-1836	110648	20 ³ / ₈	26	70	36 72	3	40
ALC-1840	110672	20 ³ / ₈	26	70	40 80	1½	42

Caster Information:

Caster with 5" Polyurethane Wheel 757 (123684)
5" Polyurethane Wheel 7112 (122180)

Freight Class: 250

Options:

XB XHD Reinforced Upright

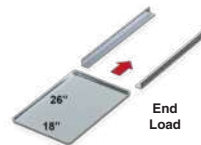

WIRE PAN RACK

- Material: Aluminum Frame 1" tubing with Chrome Steel Wire Slides, Runner Spacing: 1½"
- Application: Ideal for cooling, transporting, storing and proofing.
- Casters: 5" Polyurethane Swivel Stem

- Holds:
18" x 26" Sheet Pans by lip
14" x 18" Sheet Pans by lip
- Rolling Capacity: 800 lbs
- Weight Capacity per Runner: 30 lbs

Model Number	Order #	Overall Dimensions			Pan Cap. 18" x 26" 14" x 18"	Approx. Ship Wt
		Width	Length	Height		
		(in)	(in)	(in)	(lb)	
WP-1836B	111034	21	24	68 ³ / ₈	36 72	67

Caster Information:

Caster with 5" Polyurethane Wheel 757 (123684)
5" Polyurethane Wheel 7112 (122180)

Freight Class: 250

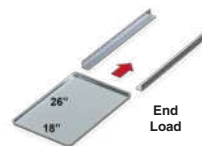

WP-1836B

As part of our commitment to continuous product improvement, Winholt reserves the right to modify materials and specifications without prior notice.

MEDIUM DUTY NESTING PAN RACKS



AL-1820N

- Material: Available in all welded aluminum or stainless steel, 1" tubing. Runner Angle: 1" x 1½"
- **Lifetime Warranty Against Rust**
- Application: Pan Rack for storage & proofing. Racks nest to save freight, floor space and labor
- Six nesting racks will take up 15 sq/ft while six standard racks take up 22.5 sq/ft
- Holds:
 - 18" x 26" Sheet Pans
 - 14" x 18" Sheet Pans
- Casters: 5" Polyurethane Swivel Stem
- Rolling Capacity: 800 lbs
- Weight Capacity per Runner: 30 lbs

Model Number	Order #	Overall Dimensions			Pan Cap.	Runner Spacing	Approx. Ship Wt
		Width	Length	Height			
		(in)	(in)	(in)	18" x 26"	(in)	(lb)
Aluminum							
AL-1810N	267371	20 ³ / ₁₀	26	70	10	6	35
AL-1820N	110066	20 ³ / ₁₀	26	70	20	3	48
Stainless Steel							
SS-1810N	289140	21	26	70	10	6	80
SS-1820N	289158	21	26	70	20	3	110

Caster Information:
 Caster with 5" Polyurethane Wheel 757 (123684)
 5" Polyurethane Wheel 7112 (122180)
Freight Class: 250



Nests to save valuable floor space!

Aluminum Top Folds when Nesting

TRANSPORT NESTING RACK

- The Aluminum Transport Nesting Rack is an ideal solution for high-traffic, fast-paced kitchens
- **Lifetime Warranty Against Rust**
- Constructed of all welded aluminum with an aluminum top and polyethylene bottom
- 21 Runners: Top 15 runners have 2½" runner spacing and bottom 6 runners have 4" runner spacing
- Rear tray stop on one side
- Nests for compact storage and easy transport of multiple carts. Includes clips to snap rack into place for security.
- Adjustable runner spacing accommodates various pan sizes
- Maneuvers on (4) 5" x 1¼" swivel polyurethane casters.

Model Number	Order #	Overall Dimensions			# of Shelves	Approx. Ship Weight
		Width	Length	Height		
		(in)	(in)	(in)	(lb)	
ALUN-2721N-DD	1152514	29	21 ¹ / ₈	75 ¹ / ₄	21	85

Caster Information:
 Caster with 5" Polyurethane Wheel 757 (123684)
 5" Polyurethane Wheel 7112 (122180)
Freight Class: 250

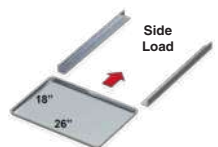

ALUN-2721N-DD

MEDIUM DUTY PAN RACKS STAINLESS STEEL - END LOAD

- Material: Stainless steel construction, 1" tubing. Runner Angle: 1" x 1 1/2"
- **Lifetime Warranty Against Rust**
- Application: For proofing, storage and transporting finished product on 18" x 26" and 14" x 18" pans and trays.
- Holds easily on heavy duty 5" polyurethane swivel stem casters
- Holds: End Load: (1) 18" x 26" full sheet pans
Side Load: (2) 18" x 14" half sheet pans
- Rolling Capacity: 800 lbs
- Weight Capacity per Runner: 30 lbs

Model Number	Order #	Overall Dimensions			Pan Cap.	Runner Spacing	Approx. Ship Wt
		Width	Length	Height			
		(in)	(in)	(in)	18" x 26"	(in)	(lb)
SS-1810B	110470	20 ³ / ₁₀	26	69 ¹ / ₅	10	6	47
SS-1812B	110488	20 ³ / ₁₀	26	69 ¹ / ₅	12	5	54
SS-1818B	110525	20 ³ / ₁₀	26	69 ¹ / ₅	18	3	65
SS-1820B	110541	20 ³ / ₁₀	26	69 ¹ / ₅	20	3	70
SS-1830B	110568	20 ³ / ₁₀	26	69 ¹ / ₅	30	2	80

Caster Information:

Caster with 5" Polyurethane Wheel 757 (123684)
5" Polyurethane Wheel 7112 (122180)

Freight Class: 250

Options:

- B** Bumpers (4)
- BP** Plate Casters 5" Polyurethane Wheel
- LC** Locking Casters
- TG-SS** Tray Guard/Stainless Steel
- PP** Prison Package
- XB** XHD Reinforced Upright



SS-1812B

MEDIUM DUTY PAN RACKS STAINLESS STEEL - SIDE LOAD

- Material: Stainless steel construction, 1" tubing. Runner Angle: 1" x 1 1/2"
- **Lifetime Warranty Against Rust**
- Application: For proofing, storage and transporting finished product on 18" x 26" pans, side loading.
- Holds: Side Load holds (2) 18" x 26" half sheet pans
- Casters: Heavy duty 5" polyurethane swivel stem casters
- Rolling Capacity: 800 lbs
- Weight Capacity per Runner: 30 lbs

Model Number	Order #	Overall Dimensions			Pan Cap.	Runner Spacing	Approx. Ship Wt
		Width	Length	Height			
		(in)	(in)	(in)	18" x 26"	(in)	(lb)
SS-2610B	110584	28 ³ / ₁₀	18	69 ¹ / ₅	10	6	34
SS-2618B	156339	28 ³ / ₁₀	18	69 ¹ / ₅	18	3	87
SS-2620B	110605	28 ³ / ₁₀	18	69 ¹ / ₅	20	3	34

Caster Information:

Caster with 5" Polyurethane Wheel 757 (123684)
5" Polyurethane Wheel 7112 (122180)

Freight Class: 250

Options:

- XB** XHD Reinforced Upright

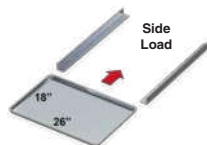

SS-2610B



CAN DISPENSING RACKS

- Material: All welded aluminum, vertical uprights and cross braces are constructed of 1½” aluminum tubing.
- **Lifetime Warranty Against Rust**
- Application: Organizes can stock and maximizes available space.
- Self-feeding feature keeps stock rotated
- Mobile units are easily maneuvered on two 5” locking swivel and two 5” rigid polyurethane plate casters.

Model Number	Order #	Type of Unit	Overall Dimensions			Can Capacity		Approx. Ship Wt (lb)
			Width (in)	Length (in)	Height (in)	#10	#5	
CR-162	112491	Stationary	25¼	35	69½	162	216	65
CR-162AJ	112504	Adjustable Feet	25¼	35	69½	162	216	65
CR-162M	112512	Mobile Station	25¼	35	69½	162	216	66

Caster Information

Swivel Plate Caster with 5” Polyurethane Wheel 738W (523039)
 Rigid Plate Caster with 5” Polyurethane Wheel 743A (128792)
 5” Polyurethane Wheel 7112 (122180)

Freight Class: 250

Options for Model CR-162M:

PP Prison Package



CR-162



CR-162M



CR-156F-BUC

FIFO CAN DISPENSING RACK



- The First-In First-Out Dispensing Can Rack keeps track of inventory and prevents waste.
- Specifically designed for standard #10 and #5 cans.
- All welded aluminum construction
- 3 columns with 4 fifo sections
- Adjustable feet

Model Number	Order #	Type of Unit	Overall Dimensions			Can Capacity		Approx. Ship Wt (lb)
			Width (in)	Length (in)	Height (in)	#10	#5	
CR-156F-BUC	1150549	Stationary	27⅞	42	81⅝	156	208	65

Freight Class: 250

HALF HEIGHT CAN DISPENSING RACKS

- Material: All welded aluminum, vertical uprights and cross braces are constructed of 1½" aluminum tubing.
- Lifetime Warranty Against Rust
- Application: Organizes can stock and maximizes available space.
- Self-feeding feature keeps stock rotated.
- Double as a workstation. Available with stainless steel, aluminum, or poly-top work surfaces.
- Mobile units are easily maneuvered on two 5" locking swivel and two 5" rigid polyurethane plate casters.



CR-54S-S

Model Number	Order #	Type of Top	Overall Dimensions			Can Capacity		Approx. Ship Wt (lb)
			Width	Length	Height	#10	#5	
			(in)	(in)	(in)			
1/2 Height - Mobile								
CR-54M	112521	Aluminum	27½	35	35	54	72	50
CR-54PT	112547	Poly Top	27½	35	35	54	72	65
CR-54S-S	112555	Stainless Steel	27½	35	35	54	72	42
CR-72M	112563	Aluminum	27½	35	40	72	96	58
CR-72PT	112571	Poly Top	27½	35	40	72	96	72
CR-72S-S	112580	Stainless Steel	25¼	35	41 ⁷ / ₁₀	72	96	62
1/2 Height - Stationary								
CR-54	1155657	Aluminum	25¼	35	32½	54	72	50
CR-54PT-ST	1155659	Poly Top	25¼	35	32½	54	72	50
CR-54S-S-ST	1155658	Stainless Steel	25¼	35	32½	54	72	50

CR-54



Caster Information

Swivel Plate Caster with 5" Polyurethane Wheel 738W (523039)
 Rigid Plate Caster with 5" Polyurethane Wheel 743A (128792)
 5" Polyurethane Wheel 7112 (122180)
Freight Class: 250

MEDIUM DUTY STEAM PAN RACKS

- Material: Available in all welded aluminum (AL) or stainless steel (SS).
Runner Angle: 1" x 1½"
- Lifetime Warranty Against Rust
- Application: Ideal for volume production of food stored in steam table pans - Hospitality, Healthcare, Restaurants
- Holds: 12" x 20" steam table pans, by lip
Full, half & 1/3 size pans by lip
- Casters: 5" Polyurethane Swivel Stem
- Rolling Capacity: 800 lbs
- Weight Capacity per Runner: 30 lbs



ALSP-1320

Model Number	Order #	Overall Dimensions			Box Cap.	Runner Spacing (in)	Approx. Ship Wt (lb)
		Width	Length	Height			
		(in)	(in)	(in)			
Side Load (Loads on the 20" Side) - Holds 2 Full Size Pans per Ledge							
ALSPR-2212	382387	23 ⁷ / ₈	27 ³ / ₈	68½	12	5	30
ALSPR-2220	382395	23 ⁷ / ₈	27 ³ / ₈	68½	20	3	42
End Load (Loads on the 12" Side) - Holds 1 Full Size Pan per Ledge							
ALSPR-1320	157788	13 ⁷ / ₈	22 ³ / ₈	68½	20	3	55
SSPR-1320	382408	13 ⁷ / ₈	22 ³ / ₈	68½	20	3	81
Double Wide, End Load (Loads on the 12" Side) - Holds 1 Pan per Ledge							
ALSPRD-1320	382424	30¾	22 ³ / ₈	68½	40	3	81

Caster Information:

Caster with 5" Polyurethane Wheel 757 (123684)
 5" Polyurethane Wheel 7112 (122180)
Freight Class: 250

Options:

XB XHD Reinforced Upright

EXPRESS
Ships in 2-3 Days!



As part of our commitment to continuous product improvement, Winholt reserves the right to modify materials and specifications without prior notice.

PIZZA PAN RACK

- Material: All welded aluminum 1" tubing.
Runner Angle: 1 1/4" x 6 1/8"
- **Lifetime Warranty Against Rust**
- Holds: 12", 14", & 16" Round Pans
17" x 19" Standard Round Pizza Pans
16" x 17" Standard Rectangle Pizza Pans
- Casters: 5" Polyurethane Swivel Stem,
two with locking casters
- Rolling Capacity: 800 lbs
- Weight Capacity per Runner: 30 lbs

Model Number	Order #	Overall Dimensions			# of Pans	Runner Spacing	Approx. Ship Wt
		Width	Length	Height			
		(in)	(in)	(in)		(in)	(lb)
PPR-26	206826	22	20	62 1/2	2	53	

Caster Information:

Swivel Square Stem Caster w/ 5" Polyurethane Wheel & Brake 757ABK (206931)
Swivel Square Stem Caster with 5" Polyurethane Wheel (PPR-26-XB)
5" Polyurethane Wheel 7112 (122180)

Freight Class: 250



PPR-26

Use the Pizza Pan Rack and Donut Screen Racks with the Pass-Through Heater Proofer!
More info on Page 60



AL-2424B

DONUT SCREEN RACKS

- Material: All welded aluminum 1" tubing.
Runner angle on model AL-2424B is 1" x 1 1/2" and model AL-2420-33D is 1" x 2"
- **Lifetime Warranty Against Rust**
- Application: Ideal for proofing and transporting donuts.
- Holds:
23" x 23" Donut Screens
24" x 24" Glazing Screens
Model AL-2420-33D also holds 24" x 33"
- Casters: 5" Polyurethane Swivel Stem
- Rolling Capacity: 800 lbs
- Weight Capacity per Runner: 30 lbs

Model Number	Order #	Overall Dimensions			Pan Cap.	Runner Spacing	Approx. Ship Wt
		Width	Length	Height			
		(in)	(in)	(in)		(in)	(lb)
AL-2420-33D	667489	24 9/10	33	69	20	3	35
AL-2424B	110226	27	24	70	20	3	43

Caster Information:

Swivel Grip Ring Caster with 5" Polyurethane Wheel 757 (123684)
5" Polyurethane Wheel 7112 (122180)

Freight Class: 250

Options:

XB XHD Reinforced Upright



OVEN RACKS - STAINLESS STEEL & ALUMINUM



Winholt Equipment Group designs and manufactures Oven Racks in a wide variety of styles and sizes. We work closely with each customer to ensure their racks are built to the exact specifications required for their ovens, in accordance with brand and performance standards. This personalized approach guarantees a perfect fit and optimal performance in every kitchen.

Specifications:

- **Lifetime Warranty Against Rust**
- Pan slides will accommodate 18" x 26" or 20" x 30" bun pans, depending on the model to include: strapped bread pans, perforated screens, muffin pans and other pan types.
- Standard Runners are 1" x 1½" wide
- Available in End Load, Side Load and Double Side Load Models
- All racks are equipped with four 4" phenolic super high temperature wheels with zerk grease fittings for easier lubrication and longer life.
- Lifting devices are constructed of stainless steel, and are designed for optimum rotation for even heat distribution.
- Weight Capacity per Runner: 30 lbs

Options Include:

- Tray Guards
- Special Slide Spacing
- Double Racks
- "B" & "D" Style Lifts
- Nesting Oven Racks
- Stainless Steel Plate Caster with Phenolic High Temp

Suggested Lubricant for Casters:

- Low Corning 44 High Temperature Bearing Grease*
- Medium Consistency
 - Resistant to Oxidation,
 - Moisture and Corrosion
- Rated: -40 to 425°F
-40 to 204°C

Compatible to many leading oven manufacturers:

- Revent
- Baxter
- Bakers Aid
- Lucks
- Hobart

Lift Design



Tray Direction

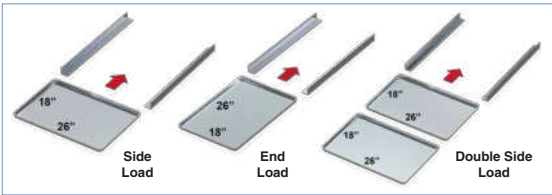

Lift Type



Oven rack specifications may vary from oven to oven, so please call us for a quote. We want to ensure a perfect fit!

Stainless Steel Casters available with Phenolic Super High Temp Wheels (7322)



To Assist In Ordering, Use The Following Chart To Build An Oven Rack:

BUILD AN OVEN RACK		A	O	V	S	1	8	1	2	B	X	A	D	1	T	G
Material	Item	Size	Tray Size	Number of Runners	Manufacturer	Lifting Device	Options									
A = Aluminum S = Stainless	OV = Oven Rack	S = Single D = Double	18 = Front 26 = Side	08 10 12 15 18 20 30	RV = Revent BX = Baxter BA = Bakers Aid LU = Lucks H = Hobart	A = Top Nipple (RV) B = 2 Channel (RV) C = 4 Channel (RV) BX1 = Baxter 1 (BX) BX2 = Baxter 2 (BX) NL = No Locator (BA) PG = Pin Guide (BA)	TG = Tray Guard									

Call Winholt at
800.444.3595 for Design Assistance and Pricing!

KNOCK-DOWN REACH-IN REFRIGERATOR INSERT RACKS

AL-1807-IR-KD

- Store sheet pans of prepped food in your fridge with these full and half size insert racks
- Material: All welded aluminum construction
- **Lifetime Warranty Against Rust**
- Holds 18" x 26" sheet pans
- Can use on fridge shelving
- Pair with Winholt Cantilever Shelving for commercial kitchen fridges and backrooms
- Knock-down design allows for easy storing and assembly

Model Number	Order #	Overall Dimensions			Pan Cap.	Runner Spacing (in)	Approx. Ship Wt (lb)
		Width	Length	Height			
		(in)	(in)	(in)			
AL-1807-IR-KD	626089	20 ³ / ₈	24	23	7	3	15
AL-1816-IR-KD	582928	20 ³ / ₈	24	51	16	3	27

Freight Class: 250



EXPRESS
Ships in 2-3 Days!



AL-1816-IR-KD



AL-1310-DBL-HD-ST

ALUMINUM DOUBLE PAN RACK

- Double your space with the Aluminum Double Rack
- Constructed of all welded aluminum with an aluminum solid top and reinforced uprights
- **Lifetime Warranty Against Rust**
- Holds: 1/2, 1/3 and 2/3 size sheet pans
- 12"W x 20"L x 6"D steam table pans
- Maneuvers on (4) swivel 5" polyurethane casters

Model Number	Order #	Overall Dimensions			# of Shelves	Approx. Ship Wt (lb)
		Width	Length	Height		
		(in)	(in)	(in)		
AL-1310-DBL-HD-ST	1142812	30 ² / ₅	21 ¹ / ₈	74 ³ / ₅	20	48

Caster Information:
(4) 5" x 1 1/4" Swivel Plate Casters with Polyurethane Wheel (738AW)
Freight Class: 250



ALUMINUM SLANTED RACK

- Aluminum Slanted Rack is an essential solution for transporting boxes, crates and lugs (maximum size of 12"W x 15"L x 13 1/8"H)
- Constructed of all welded aluminum
- 4 Shelves on each side: 13 1/8" runner spacing, 15"D x 12"W
- **Lifetime Warranty Against Rust**
- Safely transport with our slanted design and upright support for extra security
- Maneuvers on (4) swivel 5" polyurethane casters, two with brakes

Model Number	Order #	Overall Dimensions			# of Shelves	Approx. Ship Wt (lb)
		Width	Length	Height		
		(in)	(in)	(in)		
AL-1104-2S-ST	1151375	15	34 1/2	55	8	36

Caster Information:
(2) 5" x 1 1/4" Polyurethane Swivel Plate Casters (738AW)
(2) 5" x 1 1/4" Polyurethane Swivel Plate Casters with Brake
Freight Class: 250



AL-1104-2S-ST

HEAVY DUTY QUEEN MARY BANQUET CARTS ALUMINUM & STAINLESS STEEL

- Multipurpose cart designed for storage and transportation of pots, pans, wire baskets, cups, and dishes.
- Aluminum: Frame is constructed of all welded 1½" x 1½" x 1/5" reinforced aluminum. Shelves are constructed of heavy duty reinforced aluminum sheet.
- Stainless Steel: Frame is constructed of all welded 1½" x 1½" x 1/5" reinforced stainless steel. Shelves are constructed of heavy duty reinforced stainless steel sheet.
- **Lifetime Warranty Against Rust**
- Standard configuration is 3 lips flanged up and front lip down. Other configurations are available upon request.
- A wrap around bumpers protect walls, associates and equipment. Welded handle for easy maneuverability.
- Weight Capacity per Shelf (evenly distributed): 300 lbs
- Maneuvers on two 8" x 2" rigid and two 8" x 2" swivel polyurethane wheels with double race casters.

Model Number	Order #	Overall Dimensions			# of Shelves	Shelf Spacing	Approx. Ship Wt
		Width (in)	Length (in)	Height (in)			
Aluminum Queen Mary							
BNQT-3	154325	28	60	65 ² / ₅	3	27	140
BNQT-4	127546	28	60	65 ² / ₅	4	17 ³ / ₅	160
BNQT-5	112598	28	60	65 ² / ₅	5	13 ¹ / ₂	180
Stainless Steel Queen Mary							
BNQT-3-SS	232012	28	60	65 ² / ₅	3	27	295
BNQT-4-SS	168997	28	60	65 ² / ₅	4	17 ³ / ₅	340
BNQT-5-SS	232021	28	60	65 ² / ₅	5	13 ¹ / ₂	385



Caster Information:

Swivel Plate Caster with 8" Polyurethane Mold-on Wheel 73161 (123035)
Rigid Plate Caster with 8" Polyurethane Mold-on Wheel 7471 (123537)
8" Polyurethane Mold-on Wheel 7116 (122294)

Freight Class: 250



HEAVY DUTY UTILITY CARTS STAINLESS STEEL



- Ideal solution for healthcare, schools, hotels, and correctional use
- 16 Gauge shelves and standard tubing
- **Lifetime Warranty Against Rust**
- Rolling Capacity: 1200 lbs
- 14 Gauge unit and custom size available upon request.
- Casters: Standard with 5" x 2" polyurethane plate casters at no additional charge



UC-3-2133SS

Model Number	Order #	Overall Dimensions			Shelf Size (in)	Approx. Ship Wt (lb)
		Width (in)	Length (in)	Height (in)		
2 Shelves - 23½" Shelf Spacing						
UC-2-1832SS	627065	19 ¹ / ₅	38	37 ¹ / ₂	18 x 32	70
UC-2-2133SS	627081	21	39	37 ¹ / ₂	21 x 33	77
UC-2-2149SS	627111	21	55	37 ¹ / ₂	21 x 49	92
3 Shelves - 11" Shelf Spacing						
UC-3-1832SS	627073	19 ¹ / ₅	38	37 ¹ / ₂	18 x 32	84
UC-3-2133SS	627090	21	39	37 ¹ / ₂	21 x 33	93
UC-3-2149SS	627102	21	55	37 ¹ / ₂	21 x 49	115

Caster Information:

Swivel Plate Caster with 5" Polyurethane Wheel 7321CBZ (123086)
Rigid Plate Caster with 5" Polyurethane Wheel 7451(123473)
5" Polyurethane Mold-on Wheel 7023 (191038)

Freight Class: 250

Options:

PP Prison Package

As part of our commitment to continuous product improvement, Winholt reserves the right to modify materials and specifications without prior notice.

800.444.3595 | sales@winholt.com | www.winholt.com





GRAB & GO MERCHANDISER KIOSK STAINLESS STEEL CARTS

SS-BC-2748-INSULIB-TOS



Showcase Your Magnetic Branding on the Front of the Unit!

Mobile serving carts that can be used in schools, stadiums or any hospitality venue. Use this all-in-one station to distribute fresh fruit, cold drinks, snack bags and more!

- Constructed of all welded stainless steel, specifically engineered to effectively support magnetic branding and logos.
- Insulated 8" deep removable ice bin with 1" recessed drain valve. Bin holds (3) standard 12" x 20" pans (not included).
- Removable stainless steel cover with end bumpers to prevent scratching. Includes hook to hold cover in back of the unit when not in use.
- Options Include: Heavy Duty Casters, 18" Folding Shelf, Black Powder Coated Wrapping, Standard Handle, Ergonomic Handle

Model Number	Order #	Overall Dimensions			Approx. Ship Wt (lb)
		Width (in)	Length (in)	Height (in)	
Includes Overhead Shelf					
SS-BC-2748-INSULIB-TOS	1152356	28 ³ / ₅	55 ¹ / ₅	64 ¹ / ₂ - 69 ¹ / ₂	230
SS-BC-2748H29-INSULIB-TOS	1153542	28 ³ / ₅	55 ¹ / ₅	59 ¹ / ₂ - 64 ¹ / ₂	222
No Overhead Shelf					
SS-BC-2748-INSULIB	1153527	28 ³ / ₅	53 ¹ / ₅	34 ³ / ₄	198

Caster Information:

Swivel Plate Caster with 5" polyurethane wheel & brake 738AW-LCFDC (1080065)
Rigid Plate Caster with 5" polyurethane wheel 743WFDC (1080073)
Wheel 7112

Freight Class: 250

Options:

HDC 5 x 2" Heavy Duty Casters
FS18 18" Folding Shelf



Watch our Video



CHICKEN BREADING WORK STATION



- Stainless steel work station to bread chicken or other food items for frying.
- All in one station - dredge, egg wash and bread crumb all in one area making for a more efficient work environment.
- The unit includes a top shelf for spices, marinade pan and bottom cabinet for chicken storage, two tubs with lids and one sheet pan.
- Used by restaurants and supermarkets in chicken preparation areas.

Model Number	Order #	Overall Dimensions			Runner Spacing	Approx. Ship Wt
		Width	Length	Height		
		(in)	(in)	(in)	(in)	(lb)
SSBC-3322-3R-ZPC-KT	1026819	22 ¹ / ₈	33 ¹ / ₁₀	55	8	120

Caster Information:
 Swivel Plate Caster with 5" polyurethane wheel & brake 738AW-LCFDC (1080065)
 Rigid Plate Caster with 5" polyurethane wheel 743WFDC (1080073)
 Wheel 7112
Freight Class: 150



SSBC-3322-3R-ZPC-KT

Watch our Video



SS-CFR-2027-LC-OPT

STAINLESS STEEL MOBILE LANDING TABLE

This Mobile Landing Table is an ideal solution for storage, workspace, and preparation. Make the most of your space with our sturdy mobile design.

- All welded stainless steel construction
- 16 Gauge stainless steel landing pan
- Maneuvers easily on (4) 5" polyurethane swivel casters, 2 with locks
- Holds (6) 18" x 26" sheet pans
- Optional add-on utility rack that easily attaches to either side of landing rack shoulder
- Create a work station wherever needed with mobile design and locking casters

Model Number	Order #	Overall Dimensions			Runner Spacing	Approx. Ship Wt
		Width	Length	Height		
		(in)	(in)	(in)	(in)	(lb)
SS-CFR-2027-LC-OPT	1154220	23 ¹ / ₂	27	37	3 ¹ / ₂	48
Add-on Utility Rack						
SS-CFR-RACK-OPT	1154221	2 ³ / ₄	25	29 ¹ / ₂	-	20

Caster Information:
 Swivel Plate Caster with 5" polyurethane wheel & brake 738AW-LCFDC (1080065)
 Rigid Plate Caster with 5" polyurethane wheel 743WFDC (1080073)
 Wheel 7112
Freight Class: 300



Shown with Utility Rack





INGREDIENT BINS, TRIPLE

- Heavy duty plastic bins are constructed of seamless, one-piece, sanitary polyethylene. Will not chip, corrode or rust.
- Bins are available in White, Yellow and Blue, to color code for easy product identification with clear plastic covers or aluminum covers.
- Ideal height, conveniently fits under work tables, saving valuable space.
- Heavy duty frame. Bins and lids are interchangeable with other brands.
- The frame is constructed of sanitary aluminum that will not rust and maneuvers easily on large 5" polyurethane casters.

Total Capacity per Bin

- 55 lbs Flour (25 kg)
- 75 lbs Sugar (34 kg)

Model Number	Order #	Overall Dimensions			Approx. Ship Wt (lb)
		Width (in)	Length (in)	Height (in)	
Aluminum Assembly with 1 White, 1 Yellow, and 1 Blue Tub and (3) Three Clear Covers					
148PIB	111940	16 ¹ / ₈	30 ¹ / ₈	30 ¹ / ₂	28
Aluminum Assembly with 1 White, 1 Yellow, and 1 Blue Tub and (3) Three Aluminum Covers					
148PIB-ALC	963106	16 ¹ / ₈	30 ¹ / ₈	30 ¹ / ₂	28
Bins					Color
148BIN-WH	130008	9 ¹ / ₄	14 ⁵ / ₈	23 ¹ / ₄	White
148BIN-YW	129980				Yellow
148BIN-BL	182713				Blue
Covers		Material			Count
148COV	111931	Clear Plastic			1 Cover
148COV-AL	693011	Aluminum			1 Cover

Caster Information:

Caster with 5" Polyurethane Wheel 757 (123684)
5" Polyurethane Wheel 7112 (122180)

Freight Class: 150



148PIB-ALC comes with three aluminum covers.



EXPRESS
Ships in 2-3 Days!



148PIB comes with three clear plastic covers.



148PIB



AL-1868-XB-5PU-DP

ALUMINUM ROTISSERIE STORAGE TRANSPORT RACK

- Aluminum chicken rotisserie prep, storage and transport rack solution
- Safely and efficiently transport your skewered seasoned rotisserie chickens to your rotisserie ovens!
- Rack has a 6-tray capacity, each tray has a capacity to hold 6 skewers of chickens when stacked
- Load capacity per runner: 30 lbs
- Runners are 1" x 1½" aluminum extrusion.
- Holds 18" x 26" trays
- Lower stainless steel drip pan with two handles, captures liquids and ensures a safe and sanitary environment.

Model Number	Order #	Overall Dimensions			Runner Spacing	Approx. Ship Wt
		Width	Length	Height		
		(in)	(in)	(in)	(in)	(lb)
AL-1806BP-XB-5PU-DP	1043774	26 ³ / ₁₀	30 ¹ / ₈	74 ³ / ₄	6	46

Caster Information:

Swivel Plate Caster with 5" Polyurethane Wheel & Brake 738AW (523039)
5" Polyurethane Wheel 7112

Freight Class: 250



MEDIUM DUTY SHEET PAN TRUCKS ALUMINUM

- Sanitary, all welded, reinforced, rustproof aluminum frame.
- **Lifetime Warranty Against Rust**
- Ideal for storing and transporting 18" x 26" trays. Side rail design securely holds trays in place.
- Model D2027A-BPC is equipped with top cross bars for additional shelf capacity.
- Model D2027-BPC-51H-HD is heavy duty with higher sides for additional capacity.
- Maneuvers easily on two swivel plate casters and two rigid plate casters with 4" polyurethane wheels.



D2027-BPC



D2027A-BPC

Cross Bars adds Pan Capacity

Model Number	Order #	Overall Dimensions			Capacity	Approx. Ship Wt
		Width	Length	Height		
		(in)	(in)	(in)	(lb)	(lb)
D2027-BPC	111245	22	27 ¹ / ₈	32	300	22
D2027A-BPC	111270	22	27 ¹ / ₈	32	300	25
D2027-BPC-51H-HD	688642	22½	27 ¹ / ₈	51	400	40

Caster Information:

Swivel Plate Caster with 5" Polyurethane Wheel 738A (128784)
5" Polyurethane Wheel 7112 (122180)

Freight Class: 92.5



For Trays see page 136



D2027-BPC-51H-HD

As part of our commitment to continuous product improvement, Winholt reserves the right to modify materials and specifications without prior notice.

HEAVY DUTY SHEET PAN TRUCKS GALVANIZED STEEL

- Strong, all welded steel with, galvanized finish. Reinforced handles for easy maneuvering.
- Ideal for storing and transporting 18" x 26" trays. Holds approximately (100) 18" x 26" pans.
- Casters: 5" Polyurethane Swivel Plate

Model Number	Order #	Overall Dimensions			Capacity	Approx. Ship Wt
		Width	Length	Height		
		(in)	(in)	(in)	(lb)	(lb)
WHSPT-2128S	126017	21	28¾	28	600	35

Caster Information:

Swivel Plate Caster with 5" Polyurethane Wheel 738A (128784)
5" Polyurethane Wheel 7112 (122180)

Freight Class: 92.5



WHSPT-2128S

MULTI-PURPOSE DOLLY

- Constructed of aluminum
- Specifically designed for 18" x 26" standard pizza boxes and round trays
- Lifetime Warranty Against Rust
- Rolls easily on heavy duty 4" rubber plate casters.

Options:

PH-1 (101830).....Pull Handle



D-2027



PH-1 Pull Handle

Model Number	Order #	Overall Dimensions			Capacity	Approx. Ship Wt
		Width	Length	Height		
		(in)	(in)	(in)	(lb)	(lb)
D-2027	126105	20	27	8	300	25

Caster Information

Swivel Plate Caster with 5" Rubber Wheel 732 (123078)
4" Rubber Wheel 716 (122673)

Freight Class: 100



FLAT BED CARTS ALUMINUM

- All welded aluminum construction
- Solid deck with turned up lip to prevent slippage
- (4) Bumpers to protect walls and fixtures
- Prison package is designed for correctional institutions with tamper resistant hardware
- Capacity: 800 lbs

Model Number	Order #	Overall Dimensions			Capacity	Approx. Ship Wt
		Width	Length	Height		
		(in)	(in)	(in)	(lb)	(lb)
ALFC-2865-42H	661458	30	66⅞	42	800	100
ALFC-2851-42H	1043424	30	52	42	800	100
ALFC-2836-42H	1043416	30	37	42	800	100

Caster Information:

Swivel Plate Caster with 5" Rubber Wheel 732 (123078)
4" Rubber Wheel 716 (122673)

Freight Class: 100

Options:

PP Prison Package



ALFC-2865-42H



Founded in 1946

SUPERMARKET & FOOD HANDLING

Lug Carts

Bulk Movers

Platter Carts

Universal Carts

Crisping Rack

Insulated Table Grab & Go Merchandisers

Film Wrapper



MOBILE LUG CARTS ALUMINUM AND STAINLESS STEEL

AL-L-6-XB



AL-L-6

- For transport and storage of all types of products
- Minimize lifting and carrying, cut down on product handling time
- **Lifetime Warranty Against Rust**
- Carts are sanitary and easy to clean
- The carts are constructed of rustproof, all welded aluminum (AL) or stainless steel (SS) with no nuts or bolts to loosen.
- Carts have 10" spacing between runners.
- Maneuvers easily on four 5" heavy duty polyurethane swivel stem casters

ALUMINUM

Model Number	Order Number	Overall Dimensions			Capacity (Lugs)	Approx. Ship Wt (lb)
		Width	Length	Height		
		(in)	(in)	(in)		
AL-L-1	104176	16	25	19½	1	12
AL-L-1-WM	240784	16	25	26½	1	16
AL-L-2	104230	16	28	33½	2	14
AL-L-3	104264	19	27	41	3	25
AL-L-6	104281	19	27	72	6	22

Caster Information:

Swivel Square Stem Caster with 5" Polyurethane Wheel 757 (123684)

5" x 1¼" Polyurethane Wheel 7112 (122180)

Freight Class: 250

Options:

XB XHD Reinforced Upright



Lugs and lids can be found on page 139 (sold separately)



AL-L-2



STAINLESS STEEL



AL-L-1

Model Number	Order Number	Overall Dimensions			Capacity (Lugs)	Approx. Ship Wt (lb)
		Width	Length	Height		
		(in)	(in)	(in)		
SS-L-1	104310	16	25	19½	1	15
SS-L-2	104336	16	28	35½	2	21
SS-L-3	104361	19	27	41	3	33
SS-L-6	104387	19	27	72	6	40

Caster Information:

Swivel Square Stem Caster with 5" Polyurethane Wheel 757 (123684)

5" x 1¼" Polyurethane Wheel 7112 (122180)

Freight Class: 250



BULK MOVERS - 3, 6 & 8 BUSHEL ALUMINUM AND STAINLESS STEEL

- Ideal for all departments: meat, produce, fish and deli - food preparation - pack out - storage
- **Lifetime Warranty Against Rust**
- An efficient solution for backroom processing
- Use our efficient Department Color Coding System: Blue for Fish, Red for Meat, White for Produce.
- Large removable tub is constructed of sanitary, washable and steam cleanable polyethylene
- Frame constructed of all welded, rust proof aluminum or stainless steel
- Maneuvers easily on four 5" swivel polyurethane casters



Aluminum Model Number	Aluminum Order #	Stainless Model Number	Stainless Order #	Overall Dimensions			Tub Color	Approx. Ship Wt
				Width	Length	Height		
				(in)	(in)	(in)		(lb)
3 Bushel - 6,840 Cubic Inches (500 lbs) Bulk Movers - Aluminum Base								
Complete Unit (frame and tub)								
BLC-1	101602	-	-	19	26	32	White	28
Tub only - 30 Gallons								
XT-BLC	101776	-	-	19	30	12	White	6
6 Bushel - 16,632 Cubic Inches (500 lbs) Bulk Movers - Complete Unit (frame and tub)								
Aluminum		Stainless Steel						
30-6-A-WH	101477	-	-	21	33	36	White	33
30-6-A-BL	161111	30-60-SS-BL	679623				Blue	
30-6-A-RD	161103	30-6-SS-RD	515442				Red	
Tub only - 72 Gallons								
TUB-6A-WH	101725	-	-	24	33	21	White	16
TUB-6A-BL	161146	-	-				Blue	
TUB-6A-RD	101717	-	-				Red	
8 Bushel - 20,664 Cubic Inches (743 lbs) Bulk Movers - Complete Unit (frame and tub)								
Aluminum		Stainless Steel						
30-8-AL-WH	161120	30-8-SS-WH	631321	21	39½	32	White	40
30-8-AL-BL	155942	30-8-SS-BL	1051766				Blue	
30-8-AL-RD	161138	30-8-SS-RD	237753				Red	
Tub only - 90 Gallons								
TUB-8L-WH	101750	-	-	24	41	21	White	22½
TUB-8L-BL	101733	-	-				Blue	
TUB-8L-RD	101741	-	-				Red	

Caster Information:

Swivel Square Stem Caster with 5" Polyurethane Wheel 757 (123684)
5" x 1¼" Polyurethane Wheel 7112 (122180)

Complete Unit Freight Class: 250

Tub Only Freight Class: 70

Options:

DP-IAL-ALDP (64393) Aluminum Drip Pan



As part of our commitment to continuous product improvement, Winholt reserves the right to modify materials and specifications without prior notice.



AL-1210



WHP-1230

Platters found on page 136



SS-126

PLATTER CARTS - ALUMINUM AND STAINLESS STEEL

- Ideal for meat and produce departments, food service and non-food processing, transport and assembly applications.
- **Lifetime Warranty Against Rust**
- The carts are constructed of rustproof all welded aluminum (AL) or stainless steel (SS) with no nuts or bolts to loosen.
- Platters are held securely on 1½" angle runners.
- Maneuvers easily on four 5" heavy duty polyurethane swivel stem casters.

ALUMINUM

Model Number	Order #	Overall Dimensions			# of Trays	Runner Spacing	Approx. Ship Wt
		Width	Length	Height			
		(in)	(in)	(in)		(lb)	(lb)
AL-1010	103851	13 ² / ₅	26	68	(10) 10"	6	32
AL-1210	103886	15 ¹ / ₅	26	69 ¹ / ₅	(10) 12"	6	22
AL-1810B	109840	20 ² / ₅	26	67 ³ / ₄	(10) 18"	6	29
AL-1012	103860	13 ² / ₅	26	68	(12) 10"	6	25
AL-1212	103915	15 ¹ / ₅	26	69 ¹ / ₅	(12) 12"	6	24
AL-1812B	109882	20 ² / ₅	26	67 ³ / ₄	(12) 18"	5	25
AL-106	103878	13	26	44 ² / ₅	(6) 10"	6	25
AL-126	103931	15	26	44 ² / ₅	(6) 12"	6	27
AL-186	103958	20 ² / ₅	26	44 ² / ₅	(6) 18"	6	30

Caster Information:

Swivel Square Stem Caster with 5" Polyurethane Wheel 757 (123684)
5" x 1¼" Polyurethane Wheel 7112 (122180)
Freight Class: 250

Options: Specify options by adding suffix to Model Numbers

XB XHD Reinforced Upright



STAINLESS STEEL

Model Number	Order #	Overall Dimensions			# of Trays	Runner Spacing	Approx. Ship Wt
		Width	Length	Height			
		(in)	(in)	(in)		(lb)	(lb)
SS-1010	103974	13 ² / ₅	26	68	(10) 10"	6	47
SS-1206	1041197	15	30	41½	(6) 12"	6	49
SS-1210	104011	15 ¹ / ₅	26	69 ¹ / ₅	(10) 12"	6	45
SS-1810B	110470	20 ² / ₅	26	67 ³ / ₄	(10) 18"	6	51
SS-1012	103982	13 ² / ₅	26	68	(12) 10"	6	47
SS-1212	104029	15 ¹ / ₅	26	69 ¹ / ₅	(12) 12"	6	50
SS-1812B	110488	20 ² / ₅	26	67 ³ / ₄	(12) 18"	5	54
SS-106	104002	13	26	44 ² / ₅	(6) 10"	6	27
SS-126	104053	15	26	44 ² / ₅	(6) 12"	6	35
SS-186	104088	20 ² / ₅	26	44 ² / ₅	(6) 18"	6	37

Caster Information:

Swivel Square Stem Caster with 5" Polyurethane Wheel 757 (123684)
5" x 1¼" Polyurethane Wheel 7112 (122180)
Freight Class: 250



UNIVERSAL CARTS

- Constructed of all welded aluminum tubing.
- Will not rust like wire carts. Recessed shelves hold products more securely.
- Carts maneuver easily on four heavy duty polyurethane 5" stem casters
- **Lifetime Warranty Against Rust**

UNAL-4, UNAL-6, UNAL-7-32, UNAL-8

- Hold all sizes of trays, pans, or lugs up to 18" x 26"
- Carts allow for easy packing and unpacking
- Model UNAL-7-32 (seven shelves), offers double capacity, shelves hold two 10" or 12" platters side by side.
- *Model UNAL-8 does not accommodate lugs.

UNAL-5-WEG and UNAL-8-WEG

- Narrow design is compatible with trays and pans.

Model Number	Order #	Overall Dimensions			# of Shelves	Space Between Shelves (in)	Capacity (lb)	Approx. Ship Wt (lb)
		Width	Length	Height				
		(in)	(in)	(in)				
UNAL-4	103616	21	27	43	4	10	800	22
UNAL-6	103691			67 ² / ₅				6
UNAL-7-32	103747	28	32	67 ¹ / ₄	7	9	1200	38
UNAL-8*	103771	21	27	67 ² / ₅	8	7	800	33
UNAL-5-WEG	103659	16	32	42	5	7	800	30
UNAL-8-WEG	103798			67 ² / ₅				8



UNAL-8-WEG

Platters on page 136,
Lugs on page 139

Caster Information:

Swivel Square Stem Caster with 5" Polyurethane Wheel 757 (123684)

5" x 1 1/4" Polyurethane Wheel 7112 (122180)

Freight Class: 250

Options:

XB XHD Reinforced Upright



CRISPING RACKS

- For storage and handling. Facilitates restocking and rotation of stock.
- High capacity - holds seven WHBTT-1551 beige standard size 26 1/2" x 29 1/8" crisping baskets (sold separately)
- All welded aluminum construction with post design
- **Lifetime Warranty Against Rust**
- Cart maneuvers easily on 5" polyurethane casters, two swivel and two rigid



WHBTT-1551

Model Number	Order #	Overall Dimensions			Approx. Ship Wt (lb)
		Width	Length	Height	
		(in)	(in)	(in)	
AL-3207CR-M-DP	493394	26	32 1/2	79 1/4	35
Crisping Tray					
WHBTT-1551	242739	26	29	9	5

Caster Information:

Swivel Plate Caster with 5" Polyurethane Wheel 738A (128784)

Rigid Plate Caster with 5" Polyurethane Wheel 743A (128792)

5" Polyurethane Wheel 7112 (122180)

Freight Class: 250



AL-3207CR-M-DP



Grab & Go Solutions

INSULATED TABLE DISPLAY MERCHANDISER

All welded stainless steel construction. Insulated ice pan, keeps food cold and creates a self service display. Mobility allows to be used in any location. Basket drain and shut off valve at the bottom. Includes (1) AL-L-1 with gray lug for draining.

- Stainless steel construction
- **Lifetime Warranty Against Rust**
- Insulated ice pan keeps food cold and allows your customers to self service - an essential for fish departments.
- Basket drain and shut off valve at the bottom
- Includes (1) AL-L-1 with lug for draining. Conveniently slides under the unit where the valve can be opened to drain, keeping things neat and clean.
- Maneuvers easily on four polyurethane swivel casters with brakes.
- We offer many different designs on display tables and merchandisers, please contact your Winholt sales representative for more information.



SSMIT-4848-MLC-SNG-KIT

Shown with AL-L-1 lug cart w/ tub under display for draining.

Model Number	Order #	Overall Dimensions			Approx. Ship Wt
		Width	Length	Height	
		(in)	(in)	(in)	(lb)
SSMIT-4848-MLC-SNG-KIT	688167	48	48	40 1/4	156

Caster Information:

Swivel Square Stem Caster with 5" Polyurethane Wheel & Brake 738AW-LC (523055)

5" Polyurethane Wheel 7112 (122180)

Freight Class: 100

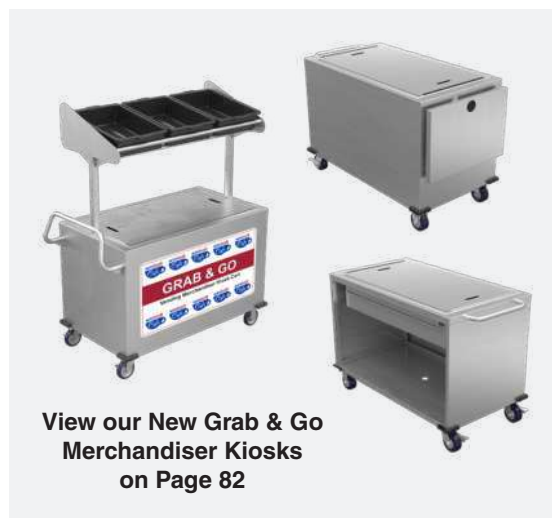

View our New Grab & Go Merchandiser Kiosks on Page 82

INSULATED ADJUSTABLE DISPLAY TABLE

- Stainless steel all welded construction
- **Lifetime Warranty Against Rust**
- Insulated removable ice bin keeps food cold and offers your customers a self serve option for packaged merchandising.
- Mobile design allows unit to be used in any section of the store.
- Removable ice bins have 2" styrofoam insulation, basket drain and shut off valve at the bottom.
- Use the removeable Lexan canopy for unpackaged food merchandising.
- Table can be used flat or adjust to 7½° or 15° angle
- Lexan side panels can also be removed.
- Maneuvers easily on four polyurethane swivel casters with brakes.

Model Number	Order #	Overall Dimensions			Approx. Ship Wt
		Width	Length	Height	
		(in)	(in)	(in)	(lb)
SSMIT-3636MLC-CAN-ADJ	982745	36	36	51½	190

Caster Information:
Swivel Square Stem Caster with 5" Polyurethane Wheel & Brake 738AW-LC (523055)
5" Polyurethane Wheel 7112 (122180)
Freight Class: 100



WE OFFER MANY OTHER GRAB & GO SOLUTIONS



SSMIT-3648MLC

- Stainless steel all welded construction
- **Lifetime Warranty Against Rust**
- Options available: tiered & perforated inserts, lexan guards, fixed and removable canopy

Model Number	Order #	Overall Dimensions			Approx. Ship Wt
		Width	Length	Height	
		(in)	(in)	(in)	(lb)
SSMIT-3648MLC	686188	36	48	38⅝	150
SSMIT-3660MLC	686196	36	60	34	185
SSMIT-4848MLC-ADJ	993153	47¾	48	47	150
SSMIT-3672ADJ-DV-XB-SNG	1057332	36	72	49½	325

Caster Information:
Swivel Square Stem Caster with 5" Polyurethane Wheel & Brake 738AW-LC (523055)
5" Polyurethane Wheel 7112 (122180)
Freight Class: 100



Removable Canopy



SSMIT-3636MLC-CAN-ADJ



SSMIT-3660MLC



SSMIT-36472ADJ-DV-XB-SNG



SSMIT-4848MLC-ADJ

As part of our commitment to continuous product improvement, Winholt reserves the right to modify materials and specifications without prior notice.



FILM WRAPPERS

- Aluminum and stainless steel construction
- **100% Pre-Tested**
- Sanitary and easily maintained, ETL Listed
- Temperature controlled Teflon covered hot plate prevents sticking. Seals film to ensure food stays fresh and protected.
- Mounting axle system
- Cut off rod temperature ranges from 265° to 310°
- Accommodates rolls of film from 8" to 18" in diameter. Core adapter holds film rolls with a 3" diameter core.
- Complete line of ETL Listed replacement parts. Our parts are fully compatible with other popular brands.
- State-of-the-art components ensure reliability and long life functionality.
- Electrical loop rated @ 8AMPS, 115 volts; overall 750 watts.



WHSS-1

Winholt offers a complete line of Film Wrapper Replacement Parts which are 100% Pre-Tested!

Our parts are fully compatible with other popular brands on the market.

Find on Page 142

Model Number	Order #	# of Rolls	Hot Plate Dimensions (in)	Overall Dimensions			Approx. Ship Wt (lb)
				Width (in)	Length (in)	Height (in)	
WHSS-1	112985	1	6 x 15	22¼	26	4¾	18

EXPRESS
Ships in 2-3 Days!





Founded in 1946

SHELVING

- Cantilever Shelving Kits
- Cantilever Shelving Build-it-Yourself
- Adjustable Shelving
- Cooler & Backroom Shelving
- Mobile Cooler Shelving
- Adjustable Shelf Mobile Cooler Shelving
- Correctional Shelving
- Keg Racks
- Aluminum Cooler Shelving
- Dunnage Racks
 - Economy
 - Heavy Duty
 - Plastic
 - Gusset Leg

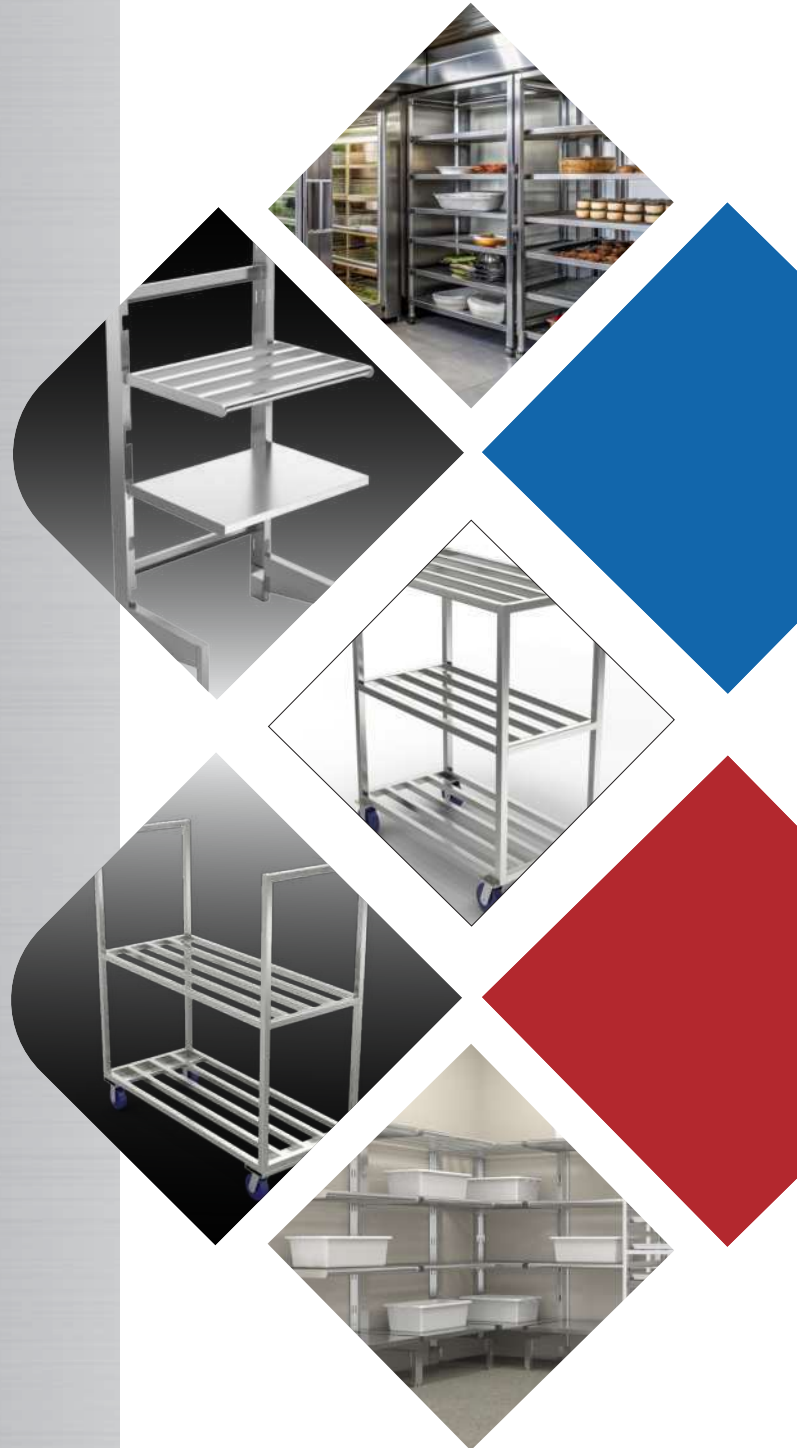



CANTILEVERED SHELVING HEAVY DUTY ALUMINUM



- Maximizes storage, freestanding shelving allows access to all corners.
- **Lifetime Warranty Against Rust**
- Wall bolting not required
- Perfect for coolers, freezers and backrooms.
- Holds up to seven shelves on 10" centers.
- Shelves adjust without tools - just lift and pull.
- Shelves easily removeable for cleaning
- Posts are 72" high with front adjustable feet.
- Weight Capacity: 2500 lbs per section (maximum for evenly distributed static load capacity)

Easy to Assemble!

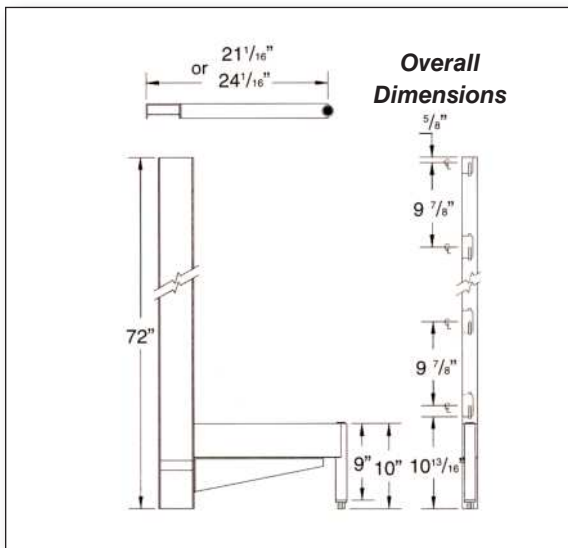

STARTER KIT

STARTER KIT INCLUDES

- (1) Right End Upright
- (1) Left End Upright
- (2) Cross Braces
- (3) or (4) Shelves
- (1) Hardware Kit



SCAS-2436-3-SU

For a full run of shelving, (1) right end upright and (1) left end upright is needed, connecting the shelf sections of the run with common uprights.

ADD-ON KIT

ADD ON KIT INCLUDES

- (1) Common Upright
- (2) Cross Braces
- (3) or (4) Shelves
- (1) Hardware Kit



SCAS-2436-3-AU

SHELVING KITS

Cantilever shelving kits offer the flexibility to create a wide range of configurations tailored to different spaces, such as backrooms, walk-in coolers, and freezers. By combining Starter Kits with Add-On Kits, designers can build layouts that maximize storage efficiency and adapt to unique requirements. This modular approach enables endless possibilities, from compact single-wall setups to expansive multi-section arrangements, ensuring an optimal solution for any storage environment.

SHELVING KITS		SHELVING KIT OPTIONS								
Starter Kit	Add-On Kit	Shelf Type		Shelf Width		Run Length		# of Shelves		
1 End Upright & 1 Common Upright (SU)	1 Common Upright (AU)	Tubular (SCAS)		21	24	36	48	60	3	4
		Solid Reinforced (SCASS)								
		T-Bar (SCAST)								
		E-Channel (SCASCH)								

SAMPLE FREEZER LAYOUT 15' X 7'

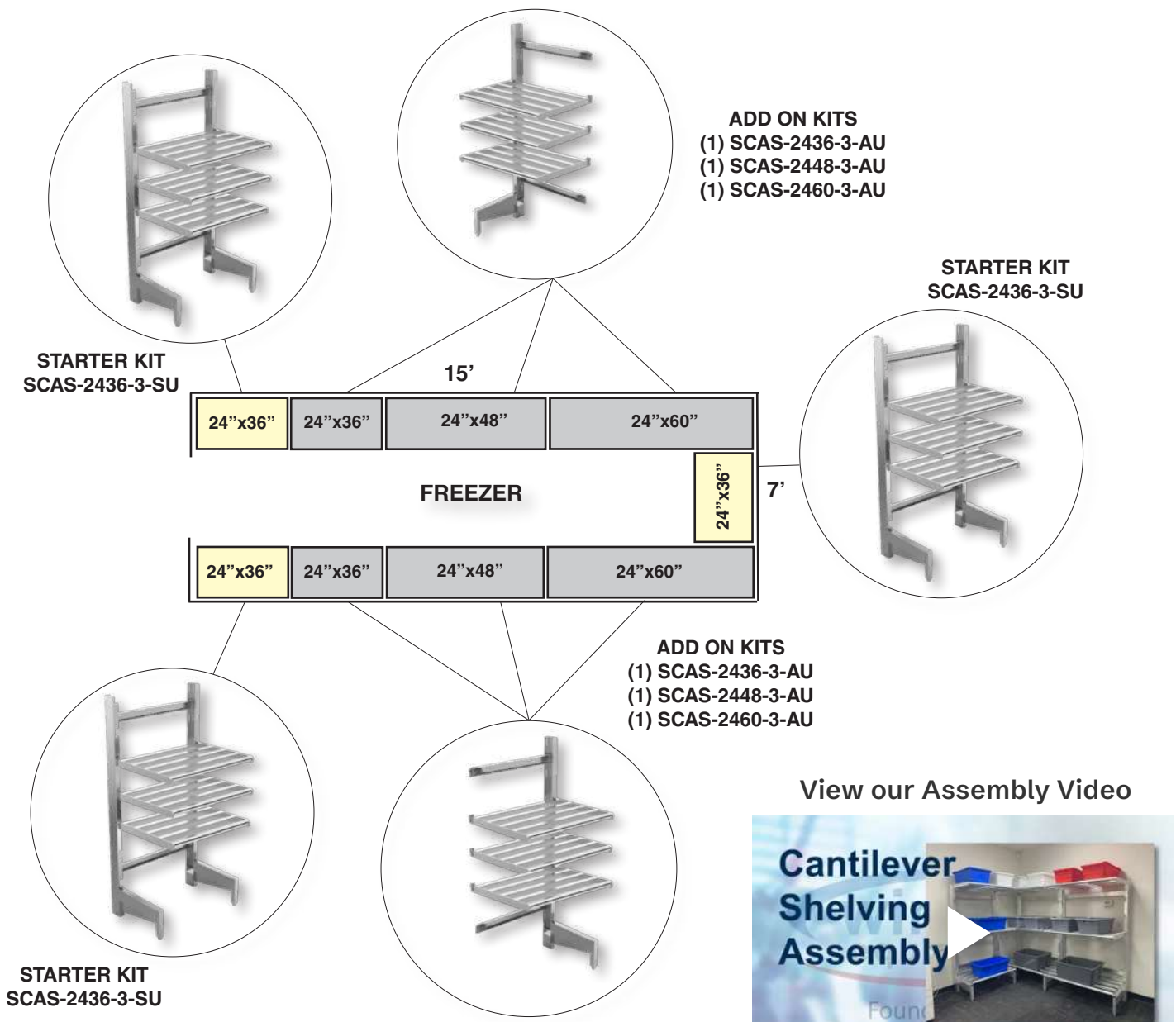

As part of our commitment to continuous product improvement, Winholt reserves the right to modify materials and specifications without prior notice.



Tubular Shelving

- 1½" x 1½" aluminum tubing provides air circulation.
- 21" deep shelf has 4 tubes spaced 5" apart
- 24" deep shelf has 5 tubes spaced 4" apart.
- Shelf Capacity: 900 lbs
(maximum for evenly distributed static load capacity)



T-Bar Shelving

- 1" x 1½" T-Bar spaced 2" apart.
- Provides air circulation and allows boxes to slide on/off easily.
- Shelf Capacity: 700 lbs (maximum for evenly distributed static load capacity)

STARTER KITS & ADD ON KITS TUBULAR SHELVING KITS



Shelving Sizes (in)	Starter Kits Tubular Shelving	Approx. Ship Wt (lb)	Add on Kits Tubular Shelving	Approx. Ship Wt (lb)
3 SHELF UNITS				
<i>21" Deep Shelves with 21" Deep Uprights</i>				
21x36	SCAS-2136-3-SU	50	SCAS-2136-3-AU	54
21x48	SCAS-2148-3-SU	57	SCAS-2148-3-AU	61
21x60	SCAS-2160-3-SU	61	SCAS-2160-3-AU	65
<i>24" Deep Shelves with 24" Deep Uprights</i>				
24x36	SCAS-2436-3-SU	56	SCAS-2436-3-AU	60
24x48	SCAS-2448-3-SU	63	SCAS-2448-3-AU	67
24x60	SCAS-2460-3-SU	70	SCAS-2460-3-AU	74
4 SHELF UNITS				
<i>21" Deep Shelves with 21" Deep Uprights</i>				
21x36	SCAS-2136-4-SU	56	SCAS-2136-4-AU	60
21x48	SCAS-2148-4-SU	66	SCAS-2148-4-AU	70
21x60	SCAS-2160-4-SU	71	SCAS-2160-4-AU	75
<i>24" Deep Shelves with 24" Deep Uprights</i>				
24x36	SCAS-2436-4-SU	64	SCAS-2436-4-AU	68
24x48	SCAS-2448-4-SU	77	SCAS-2448-4-AU	81
24x60	SCAS-2460-4-SU	84	SCAS-2460-4-AU	88

Freight Class: 70

T-BAR SHELVING KITS

Shelving Sizes (in)	Starter Kits T-Bar Shelving	Approx. Ship Wt (lb)	Add on Kits T-Bar Shelving	Approx. Ship Wt (lb)
3 SHELF UNITS				
<i>24" Deep Shelves with 24" Deep Uprights</i>				
24x36	SCAST-2436-3-SU	56	SCAST-2436-3-AU	60
24x48	SCAST-2448-3-SU	63	SCAST-2448-3-AU	67
24x60	SCAST-2460-3-SU	70	SCAST-2460-3-AU	74
4 SHELF UNITS				
<i>24" Deep Shelves with 24" Deep Uprights</i>				
24x36	SCAST-2436-4-SU	65	SCAST-2436-4-AU	69
24x48	SCAST-2448-4-SU	75	SCAST-2448-4-AU	79
24x60	SCAST-2460-4-SU	83	SCAST-2460-4-AU	87

Freight Class: 70

STARTER KITS & ADD ON KITS SOLID REINFORCED SHELVING KITS



Shelving Sizes	Starter Kits Solid Shelving	Approx. Ship Wt	Add on Kits Solid Shelving	Approx. Ship Wt
(in)		(lb)		(lb)
3 SHELF UNITS				
<i>21" Deep Shelves with 21" Deep Uprights</i>				
21x36	SCASS-2136-3-SU	62	SCASS-2136-3-AU	66
21x48	SCASS-2148-3-SU	72	SCASS-2148-3-AU	76
21x60	SCASS-2160-3-SU	85	SCASS-2160-3-AU	89
<i>24" Deep Shelves with 24" Deep Uprights</i>				
24x36	SCASS-2436-3-SU	65	SCASS-2436-3-AU	69
24x48	SCASS-2448-3-SU	78	SCASS-2448-3-AU	82
24x60	SCASS-2460-3-SU	88	SCASS-2460-3-AU	92
4 SHELF UNITS				
<i>21" Deep Shelves with 21" Deep Uprights</i>				
21x36	SCASS-2136-4-SU	73	SCASS-2136-4-AU	77
21x48	SCASS-2148-4-SU	86	SCASS-2148-4-AU	90
21x60	SCASS-2160-4-SU	103	SCASS-2160-4-AU	107
<i>24" Deep Shelves with 24" Deep Uprights</i>				
24x36	SCASS-2436-4-SU	77	SCASS-2436-4-AU	81
24x48	SCASS-2448-4-SU	94	SCASS-2448-4-AU	98
24x60	SCASS-2460-4-SU	107	SCASS-2460-4-AU	111

Freight Class: 70



Solid Reinforced Shelving

- Aluminum sheet with aluminum cross tubes underneath for support.
- Ideal for smaller merchandise.
- Shelf Capacity: 700 lbs (maximum for evenly distributed static load capacity)

E-CHANNEL SHELVING KITS

Shelving Sizes	Starter Kits E-Channel Shelving	Approx. Ship Wt	Add on Kits E-Channel Shelving	Approx. Ship Wt
(in)		(lb)		(lb)
3 SHELF UNITS				
<i>24" Deep Shelves with 24" Deep Uprights</i>				
24x36	--	--	SCASCH-2436-3-AU	63
24x48	--	--	SCASCH-2448-3-AU	70
24x60	SCASCH-2460-3-SU	73	SCASCH-2460-3-AU	77
4 SHELF UNITS				
<i>24" Deep Shelves with 24" Deep Uprights</i>				
24x36	SCASCH-2436-4-SU	69	SCASCH-2436-4-AU	71
24x48	SCASCH-2448-4-SU	78	SCASCH-2448-4-AU	80
24x60	SCASCH-2460-4-SU	87	SCASCH-2460-4-AU	91

Freight Class: 70



E Channel Shelving

- 4" x 1½" aluminum 14 gauge "E" Channel.
- Provides increased surface area, yet allows for air circulation.
- Channel is welded inside a frame of tubing and flat bar.
- 21" deep shelves have 2 channels
- 24" deep shelf has 3 channels
- Shelf Capacity: 1000 lbs (maximum for evenly distributed static load capacity)

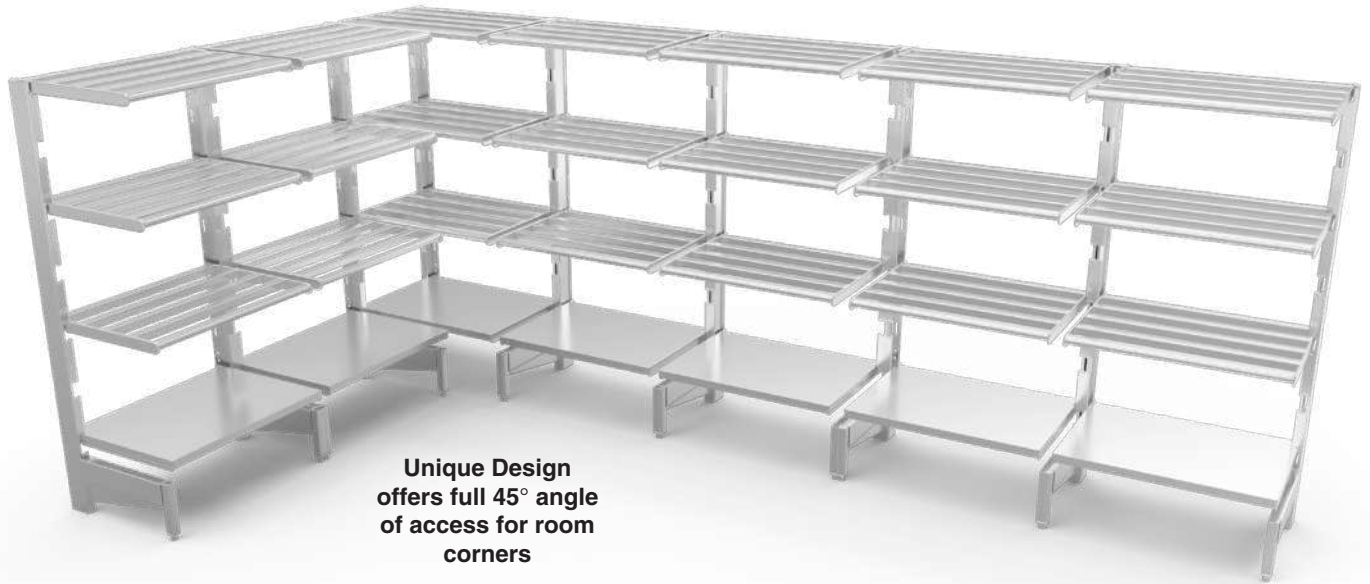

Unique Design
offers full 45° angle
of access for room
corners

DESIGN YOUR STORAGE SYSTEM CANTILEVERED SHELVING

IT'S EASY WITH COMPONENT PARTS!

- You can design your storage system with our list of component parts.
- Maximize storage, free standing shelving allows access to all corners.
- **Lifetime Warranty Against Rust**
- Wall bolting not required.
- Perfect for coolers, freezers and backrooms
- Holds up to seven shelves on 10" centers
- Shelves adjust without tools - just lift and pull
- Posts are 72" high with front adjustable feet.
- Weight Capacity: 2500 lbs per section (maximum for evenly distributed static load capacity)

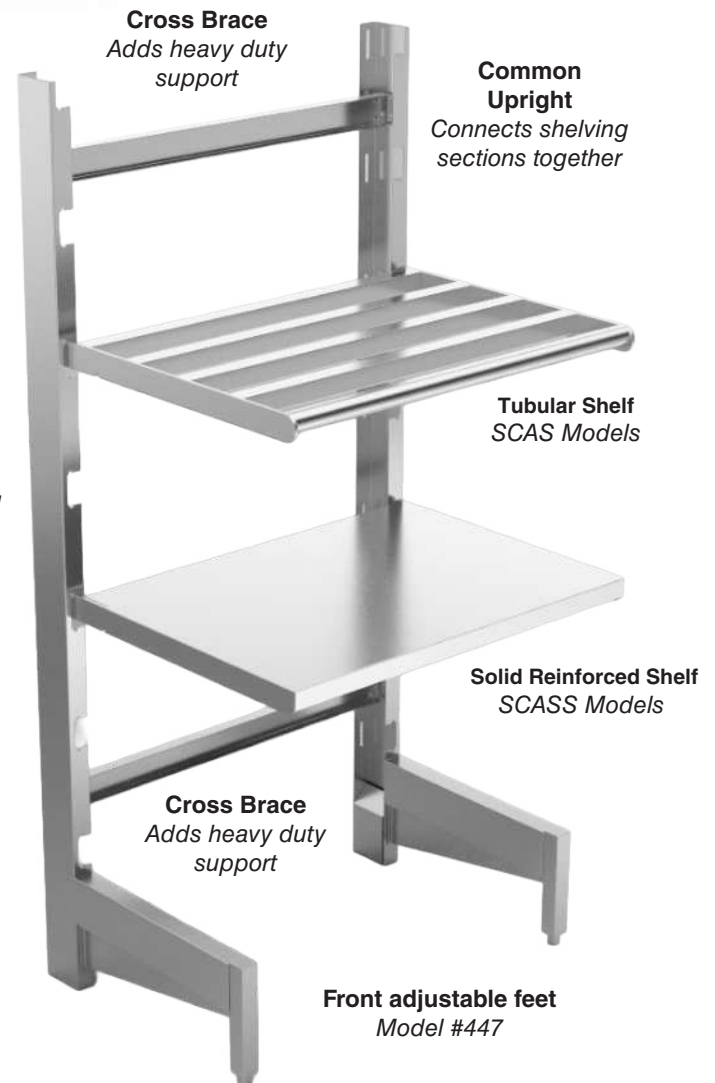

Cross Brace
Adds heavy duty
support

Common Upright
Connects shelving
sections together

Tubular Shelf
SCAS Models

Left Upright
Left side of shelving
run end support

Solid Reinforced Shelf
SCASS Models

Cross Brace
Adds heavy duty
support

Front adjustable feet
Model #447

CANTILEVERED SHELVING HEAVY DUTY ALUMINUM COMPONENT PART LIST

Winholt's cantilevered shelving component parts allow customers to design and upgrade their backroom with sleek, stable, sanitary shelving. Our cantilever shelving components are sold on their own, allowing customers who have ordered kits to replace parts, add shelves, upgrade their kits, or extend their layout. Our components include shelves, uprights, cross braces, and hardware.

Shelves:

- Tubular, Solid Reinforced, T-Bar, E-Channel
- 21" & 24" depths
- 36", 48" & 60" lengths.

Uprights:

- 21" deep upright for 21" deep shelves.
- 24" deep uprights for 24" deep shelves.
- Heavy Duty 1/8" thick 4" x 1 3/4" aluminum channel holds up to seven shelves on 10" centers.
- 72" high with outer leg adjustable foot.

Cross Braces:

- 36", 48" and 60" lengths.
- Heavy duty aluminum channel 1" x 2 1/2" x 1/8".

Hardware:

- Hex Head Bolts & Nuts, Split Lock Washers

Watch our Assembly Video:



Quick set up and modular design - Our Cantilever Shelving is easy to assemble and redesign, with no wall bolting necessary, sleek lightweight aluminum components, and minimal tools needed!

Model Number	Order #	Overall Dimensions	Approx. Ship Wt
		(in)	(lb)
Tubular Shelves			
SCAS-2136	104926	21" x 36"	7
SCAS-2148	104934	21" x 48"	9
SCAS-2160	104942	21" x 60"	10
SCAS-2436	104969	24" x 36"	9
SCAS-2448	104977	24" x 48"	11
SCAS-2460	104985	24" x 60"	13
Solid Reinforced Shelves			
SCASS-2136	106075	21" x 36"	11
SCASS-2148	106083	21" x 48"	14
SCASS-2160	106091	21" x 60"	18
SCASS-2436	106112	24" x 36"	12
SCASS-2448	106121	24" x 48"	16
SCASS-2460	106139	24" x 60"	19
T-Bar Shelves			
SCAST-2436	164021	24" x 36"	9
SCAST-2448	164030	24" x 48"	11
SCAST-2460	164048	24" x 60"	13
E-Channel			
SCASCH-2436	206762	24" x 36"	10
SCASCH-2448	206771	24" x 48"	12
SCASCH-2460	206789	24" x 60"	14
Uprights			
SCASU-24L	106542	24" Left Upright	12
SCASU-24R	106551	24" Right Upright	
SCASU-24	106534	24" Common Upright	17
Cross Braces and Hardware			
SCASC-36	105671	Cross Brace (order 2 per section)	4
SCASC-48	105689		5
SCASC-60	105697		6
SCAS-HW	105451	Hardware Kit (1 for each section)	1

Other sizes available upon request.

Freight Class: 150



As part of our commitment to continuous product improvement, Winholt reserves the right to modify materials and specifications without prior notice.

800.444.3595 | sales@winholt.com | www.winholt.com



SANI-ADJUSTABLE ALUMINUM SHELVING COMPONENT PARTS



- You can design your storage system with our list of component parts.
- **Lifetime Warranty Against Rust**
- Perfect for coolers, freezers and backrooms
- Holds up to seven shelves on 10" centers
- Easily adjustable shelves
- Posts come in a variety of heights to accommodate your requirements.

Easy Order Instructions for Component Parts

To order a 4 foot section with three Tubular shelves, 20" wide and 68" high, you need the following:

- (3) -SAS2048 (Tubular Shelves 20" x 48")
- (4) -SASP-68 (Poles 68" high)



TUBULAR SHELVING

- Constructed of all welded, heavy duty, sanitary aluminum 1¼" x 1½" cross tubes for improved air circulation and strength.
- Shelf Capacity: 2000 lbs (maximum for evenly distributed static load capacity)

Model Number	Order #	Overall Dimensions		# of Cross Tubes	Approx. Ship Wt (lb)
		Width	Length		
		(in)	(in)		
SAS2036	107060	20	36	4	8
SAS2048	107086		48		10
SAS2060	107094		60		12
SAS2072	107115		72		14
SAS2096	107123		96		15
SAS2436	107140	24	36	5	10
SAS2448	107166		48		13
SAS2460	107174		60		15
SAS2472	107182		72		18

Freight Class: 150

Tubular Shelving
SAS Series

REINFORCED SOLID SHELVING

- Constructed of all welded, heavy duty, sanitary aluminum sheet metal with cross tubes underneath for extra strength.
- Shelf Capacity: 800 lbs (maximum for evenly distributed static load capacity)

Reinforced Solid Shelving SASSR Series Bottom & Top View

Model Number	Order #	Overall Dimensions		Approx. Ship Wt (lb)
		Width	Length	
		(in)	(in)	
SASSR2036	107570	20	36	11
SASSR2048	107588		48	13
SASSR2060	107596		60	15
SASSR2436	107617	24	36	11
SASSR2448	107625		48	14
SASSR2460	107633		60	17

Freight Class: 150



Bottom Shelf

Top Shelf

SANI-ADJUSTABLE SHELVING POLES

- With 2" marked increments for easy set-up. Standard with plastic caps on pole ends. 12" poles are ideal for knock-down dunnage racks.



Model Number	Order #	Approx. Height	Approx. Ship Wt
		(in)	(lb)
SASP-54	107211	54	3
SASP-68	107220	68	4
SASP-76	107262	76	5
SASP-84	167775	84	6

Freight Class: 150

Options:

SASP-ADJ (107297) Set of (4) Adjustable Bullet Feet.

SANI-ADJUSTABLE SHELVING MOBILE

- Easy conversion from a stationary unit to a mobile unit.
- Overall Capacity 1200 lbs (544 kg).

Model Number	Order #	Description
SAS-MK	106913	(4) 5" Swivel Stem Casters

Freight Class: 70



SAS-MK Kit

COOLER AND BACKROOM SHELVING

- Sanitary and easy to clean. Constructed of all welded, heavy duty, sanitary aluminum.
- Mobile units roll easily on two rigid and two swivel heavy duty casters, with 6" x 2" phenolic wheels.

All sizes available as mobile units



ALSCS-48-420



ALSTB-60-420

Options for Mobile Units:

- ALMCS** Mobile Tubular Bar Unit
- ALMTB** Mobile T-Bar Unit
- ALMCH** Mobile E-Channel Unit

LC Locking Casters

Caster Information:

- Swivel Plate Caster with 6" Phenolic Wheel & Brake 7311CBZ (256911)
- Rigid Plate Caster with 6" Phenolic Wheel 746 (123481)
- 6" Phenolic Wheel 7119 (122331)

Model Number	Order #	Overall Dimensions			# of Shelves	Approx. Ship Wt (lb)		
		Width	Length	Height				
		(in)	(in)	(in)				
Tubular Bar Style - Shelf Capacity 1500 lbs								
ALSCS-48-220	102269	20	48	60	2 48½" Between Shelves	24		
ALSCS-48-224	102277	24				28		
ALSCS-60-220	102314	20	60			29		
ALSCS-60-224	102322	24				33		
ALSCS-36-320	143511	20	36	60	3 22½" Between Shelves	26		
ALSCS-36-324	143693	24				31		
ALSCS-48-320	102285	20	48			31		
ALSCS-48-324	102293	24				37		
ALSCS-60-320	102331	20	60			36		
ALSCS-60-324	102349	24				44		
T-Bar Style - Shelf Capacity 1000 lbs								
ALSTB-48-320	165112	20	48			60	3 22½" Between Shelves	36
ALSTB-48-324	152979	24		41				
ALSTB-60-320	165104	20	60	41				
ALSTB-60-324	152987	24		48				
E-Channel - Shelf Capacity 1500 lbs								
ALSCH-48-220	206498	20	48	60	2 48½" Between Shelves	25		
ALSCH-48-224	206501	24				29		
ALSCH-60-220	206535	20	60			30		
ALSCH-60-224	206543	24				34		
ALSCH-48-320	206586	20	48	60	3 22½" Between Shelves	33		
ALSCH-48-324	206594	24				39		
ALSCH-60-320	206615	20	60			38		
ALSCH-60-324	206623	24				46		

Freight Class: 400



MOBILE COOLER SHELVING

- Sanitary and easy to clean. Constructed of all welded, heavy duty, sanitary aluminum.
- Ideal for boxed meat, produce, prepared food, and more.
- Mobile units roll easily on two rigid and two swivel heavy duty casters, with 6" x 2" phenolic wheels.

Model Number	Order #	Overall Dimensions			# of Shelves	Space Between Shelves (in)	Approx. Ship Wt (lb)
		Width	Length	Height			
		(in)	(in)	(in)			
Mobile - Tubular - Shelf Capacity 1500 lbs							
ALMCS-36-424	180988	24	36	60	4	15 ¹ / ₈	70
ALMCS-48-320	102171	20	48	60	3	22 ¹ / ₂	65
ALMCS-48-324	102189	24	48	60	3	22 ¹ / ₂	73
ALMCS-60-320	186968	20	60	60	3	22 ¹ / ₂	76
ALMCS-60-324	132249	24	60	60	3	22 ¹ / ₂	80
Mobile - E-Channel - Shelf Capacity 1500 lbs							
ALMCH-48-220	244486	20	48	60	2	34 ¹ / ₂	40
ALMCH-48-320	244494	20	48	60	3	22 ¹ / ₂	50
Heavy Duty - Tubular - Total Capacity 3000 lbs							
SMC-63	102411	25	63	71	2	22 ¹ / ₂	70

Caster Information:

Swivel Plate Caster with 6" Phenolic Wheel & Brake 7311CBZ (256911)
 Rigid Plate Caster with 6" Phenolic Wheel 746 (123481)
 6" Phenolic Wheel 7119 (122331)

Freight Class: 300

Options:

LC Locking Casters



ALMCS-48-324
Heavy Duty
6" Casters



SMC-63

ADJUSTABLE SHELF MOBILE COOLER SHELVING

- Sanitary and easy to clean. Constructed of all welded, sanitary aluminum.
- Heavy duty adjustable shelves with 4 adjustment positions. Shelves are reinforced with 1.5" sq. aluminum tube uprights. Runners are 0.125" aluminum extrusion.
- Very Versatile - shelf spacing can be adjusted to meet the dimensions of product
- Maneuvers easily on 6" phenolic swivel casters, two with brakes.



Model Number	Order #	Overall Dimensions			# of Shelves	Approx. Ship Wt (lb)
		Width	Length	Height		
		(in)	(in)	(in)		
Mobile - Tubular - 500 lbs capacity per shelf						
ALMCS-60-224-79H-2S-PBX	1041710	24	62 ⁷ / ₈	79	4	70

Caster Information:

Swivel Plate Caster with 6" Phenolic Wheel & Brake 7311CBZ (256911)
 Rigid Plate Caster with 6" Phenolic Wheel 746 (123481)
 6" Phenolic Wheel 7119 (122331)

Freight Class: 300



ALMCS-60-224-79H-2S-PBX

As part of our commitment to continuous product improvement, Winholt reserves the right to modify materials and specifications without prior notice.

800.444.3595 | sales@winholt.com | www.winholt.com





ALSCS-48-320-CM

Tubular Shelving

- Great in freezers for increased air flow and where large boxes are stored.
- Shelf spacing on a 3 shelf unit is 22"
- Capacity per shelf: 1500 lbs

T-Bar Shelving

- Great in cooler areas where small boxes and small food items may be stored.
- Shelf Spacing on a 3 shelf unit is 22"
- Capacity per shelf: 1000 lbs

To order T-Bar Shelving use the following:

Replace Prefix with "ALSTB" in the models in the chart.

Channel Shelving

- This design gives you the best in strength and functionality.
- Stores boxes or small food items.
- Works great in dry storage, coolers and freezers.
- Shelf spacing on a 3 shelf unit is 22"
- Capacity per shelf: 1500 lbs

To order E-Channel Shelving use the following:

Replace Prefix with "ALSCH" in the models in the chart.

CORRECTIONAL ALL WELDED SHELVING

- All welded aluminum shelving for maximum weight capacities.
- Mitered corners are contraband proof corners - specifically designed for correctional environments and increase the weight capacity of the unit.
- Plastic feet are standard.

Model Number	# of Shelves	Dimensions (WxDxH)	Approx. Ship Weight
		(In)	(lb)
3 Shelves, 20" Deep			
ALSCS-36-320-CM	3	36 x 20 x 60	26
ALSCS-42-320-CM	3	42 x 20 x 60	28
ALSCS-48-320-CM	3	48 x 20 x 60	31
ALSCS-52-320-CM	3	52 x 20 x 60	33
ALSCS-60-320-CM	3	60 x 20 x 60	36
ALSCS-72-320-CM	3	72 x 20 x 60	41
3 Shelves, 24" Deep			
ALSCS-36-324-CM	3	36 x 24 x 60	31
ALSCS-42-324-CM	3	42 x 24 x 60	34
ALSCS-48-324-CM	3	48 x 24 x 60	37
ALSCS-52-324-CM	3	52 x 24 x 60	40
ALSCS-60-324-CM	3	60 x 24 x 60	44
ALSCS-72-324-CM	3	72 x 24 x 60	51
4 Shelves, 20" Deep			
ALSCS-36-420-CM	4	36 x 20 x 72	41
ALSCS-42-420-CM	4	42 x 20 x 72	45
ALSCS-48-420-CM	4	48 x 20 x 72	49
ALSCS-52-420-CM	4	52 x 20 x 72	53
ALSCS-60-420-CM	4	60 x 20 x 72	57
ALSCS-72-420-CM	4	72 x 20 x 72	65
4 Shelves, 24" Deep			
ALSCS-36-424-CM	4	36 x 24 x 72	48
ALSCS-42-424-CM	4	42 x 24 x 72	53
ALSCS-48-424-CM	4	48 x 24 x 72	58
ALSCS-52-424-CM	4	52 x 24 x 72	63
ALSCS-60-424-CM	4	60 x 24 x 72	68
ALSCS-72-424-CM	4	72 x 24 x 72	77

Freight Class: 400

Options:

ADJ Adjustable Feet

MLC Mobile Unit with Casters



KEG RACKS



- Heavy duty aluminum
- (2) E-channel shelves for sanitary beer keg storage.
- (1) Top tubular shelf for other lightweight supplies.
- All shelves are fully adjustable.
- Three sizes to choose from, other sizes available upon request.

Model Number	Order #	Dimensions (WxLxH)	Approx. Ship Wt
		(in)	(lbs)
BKR-302076	1140901	20 x 30 x 76	58
BKR-601776	1141020	17 x 60 x 76	128
BKR-722076	1140900	20 x 72 x 76	128



Freight Class: 150



ALMCS-60-424-CR-HD

ALUMINUM COOLER SHELVING



- Sanitary and easy to clean. Constructed of all welded, sanitary aluminum.
- (4) 1.5" sq. aluminum tubular shelves.
- 14" Top shelf runner spacing, 22" bottom (2) shelves runner spacing
- Maneuvers easily on 6" swivel casters with polyurethane wheels, two swivel and two with brakes. Specifically designed to withstand low temperatures.

Model Number	Order #	Overall Dimensions			# of Shelves	Approx. Ship Wt
		Width	Length	Height		(lb)
		(in)	(in)	(in)		
ALMCS-60-424-CR-HD	1155722	24	60	79½	4	145

Caster Information:

Swivel Plate Caster with 6" x 2" Polyurethane LOW TEMP Wheel 7326LTG (1020530)
 Rigid Plate Caster with 6" x 2" Polyurethane LOW TEMP Wheel 7417LTG (977137)

Freight Class: 150

DUNNAGE RACKS ECONOMY



- Prolongs product life by circulating air underneath.
- 12" height above floor meets all sanitary health codes.
- All welded 1½" x 1½" heavy duty, rustproof aluminum tube construction.
- Each leg has plastic caps (model 441)

Model Number	Order #	Length	Capacity	Approx. Ship Wt
		(in)	(lb)	(lb)
20"W x 12"H				
DASQ-3-1220	133866	36	2100	8
DASQ-4-1220	133874	48	1800	11
DASQ-5-1220	133882	60	1500	12
24"W x 12"H				
DASQ-3-1224	133891	36	2100	10
DASQ-4-1224	133903	48	1800	12
DASQ-5-1224	133911	60	1500	14
20"W x 8"H				
DASQ-3-820	156161	36	2100	10
DASQ-4-820	154018	48	1800	12
DASQ-5-820	153550	60	1500	14
24"W x 8"H				
DASQ-2-824	155141	36	2100	11
DASQ-3-824	138237	36	2100	12
DASQ-4-824	138245	48	1800	13
DASQ-5-824	153568	60	1500	14

Freight Class: 70



DASQ-4-1224

EXPRESS
Ships in 2-3 Days!





ALSQ-4-1224



PLSQ-4-1222-GY



DPLSQ-4-1222-BK



DRAL-4-1224

DUNNAGE RACKS HEAVY DUTY



- Prolongs product life by circulating air underneath.
- Supports high capacity loads on all welded 1 3/4" x 1 1/2" aluminum tube construction.
- 12" and 8" height above the floor meets all sanitary health codes
- Each leg has plastic caps (model 441)

Model Number	Order #	Length	Capacity	Approx. Ship Wt
		(in)	(lb)	(lb)
20"W x 12"H				
ALSQ-3-1220	102971	36	3000	8
ALSQ-4-1220	103085	48	2500	10
ALSQ-5-1220	103202	60	2000	12
24"W x 12"H				
ALSQ-3-1224	102980	36	3000	10
ALSQ-4-1224	103093	48	2500	12
ALSQ-5-1224	103211	60	2000	14
20"W x 8"H				
ALSQ-3-820	103034	36	3000	10
ALSQ-4-820	103181	48	2500	12
ALSQ-5-820	103245	60	2000	14
24"W x 8"H				
ALSQ-3-824	103042	36	3000	10
ALSQ-4-824	103190	48	2500	12
ALSQ-5-824	103253	60	2000	14

Freight Class: 70

DUNNAGE RACKS, PLASTIC

- Solid, one piece plastic construction will not chip, corrode or rust.
- All are a full 12" height which is double the HACCP guidelines.
- Rounded corners helps prevent bag puncturing.
- Dunnage Racks eliminate condensation buildup. Easy to wash or steam clean.

Model Number	Order #	Length	Color	Capacity	Approx. Ship Wt
		(in)		(lb)	(lb)
22"W x 12"H					
PLSQ-3-1222-GY	207757	36	Gray	2200	18
PLSQ-4-1222-GY	207765	48	Gray	2200	21
PLSQ-5-1222-GY	207773	60	Gray	2200	24
22"W x 12"H					
DPLSQ-3-1222-BK	408292	36	Black	2200	18
DPLSQ-4-1222-BK	229041	48	Black	2200	21
DPLSQ-5-1222-BK	408305	60	Black	2200	24

Freight Class: 70

DUNNAGE RACKS, GUSSET LEG



- Gusset legs support heavy loads.
- All welded heavy duty, rustproof aluminum construction
- Also available in Electroplated Steel with a minimum order of 50 units
- Optional 1" Safety Flanged Foot available upon request.

Model Number	Order #	Length	Capacity	Approx. Ship Wt
		(in)	(lb)	(lb)
Aluminum - 24"W x 12"H				
DRAL-4-1224	103501	48	2500	14

Freight Class: 70

As part of our commitment to continuous product improvement, Winholt reserves the right to modify materials and specifications without prior notice.

800.444.3595 | orders@winholt.com | www.winholt.com

E-COMMERCE & DISTRIBUTION

- Fork-Liftable Caged Carts
- Fork-Liftable Order Picking Tables
- Distribution Tow Carts
- On-Line Order Picking Work Station
- Ladder Carts
- U-Boat Picking & Stock Cart
- Slanted Shelf Picking Cart
- Tow Picking Cart
- Mobile Caged Transport Cart
- Picking Shelf Carts
- Adjustable Picking Cart
- Order Picking Curbside Pickup Delivery Cart





EC-3040-71H-SEC

FORK-LIFTABLE CAGED CART

- Constructed of steel, with powder coated gray body and safety yellow shelves
- Caged on three sides to prevent merchandise from falling. Back of the unit opens for easy unloading.
- Non-skid safety surface on the fold-up shelves to hold a variety of product sizes
- Ergonomically placed D-shaped handles
- Non-skid safety step when being lifted
- Load Capacity:
 - (2) Adjustable Shelves: 200 lbs
 - (1) Base: 600 lbs

Model Number	Order #	Overall Dimensions			Approx. Ship Wt
		Width	Length	Height	
		(in)	(in)	(in)	(lb)
EC-3040-71H-SEC	1095718	40½	44 ⁷ / ₈	70¾	95

Caster Information:

Swivel Caster with 6" Polyurethane Wheel & brake 7326W-BK (630045)

Rigid Caster with 6" Polyurethane Wheel 7417W (522618)

6" Polyurethane Wheel 7129 (122446)

Freight Class: 250

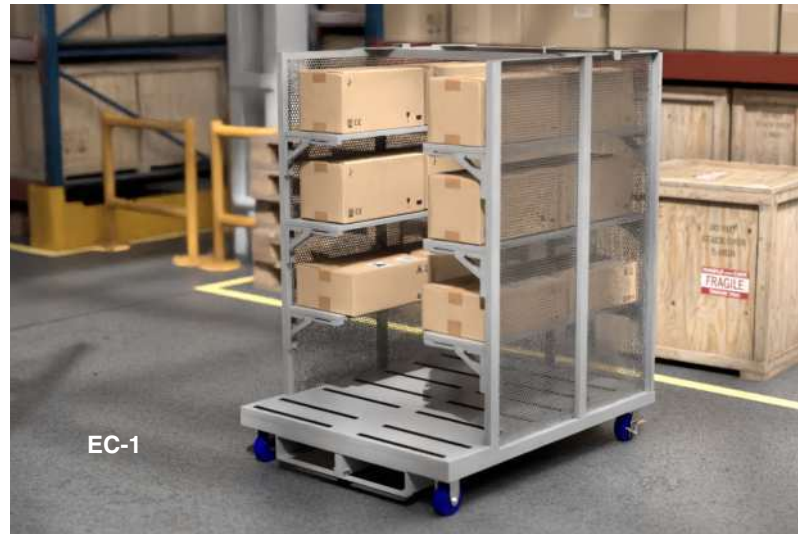

EC-1

FORK-LIFTABLE CAGED CART

- This Forkliftable Caged Cart reduces manual labor for warehouses and distribution centers.
- Welded heavy duty steel construction, powder coated gray
- 16 Gauge expanded metal enclosure, caged on three sides to prevent merchandise from falling off the cart. Back of the unit opens for easy unloading.
- (6) Shelves fold up to accommodate a variety of different sized packages

Model Number	Order #	Overall Dimensions			Total Load Capacity	Approx. Ship Wt
		Width	Length	Height		
		(in)	(in)	(in)	(lb)	(lb)
EC-1	-	46	57	69 ¹ / ₁₀	3000	120

Caster Information:

Swivel Plate Caster with 5" Polyurethane Wheel & Brake

738AW-LC (523055)

Rigid Plate Caster with 5" Polyurethane Wheel 743W (523063)

5" Polyurethane Wheel 7112 (122180)

Freight Class: 250



EC-1

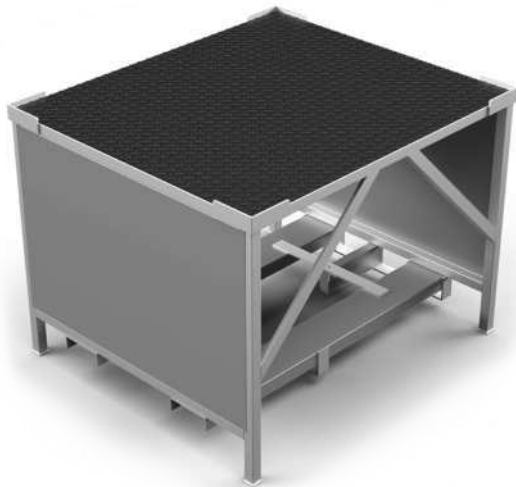

ST-OPP-4248H36

FORK-LIFTABLE ORDER PICKING TABLE

- Constructed of all welded steel, ensures durability for heavy duty use
- Powder coated gray
- Diamond steel top to prevent slipping
- Forklift pockets available from both sides
- Ergonomic raised platform prevents any physical strain on associates during order picking.
- Load Capacity: 2000 lbs

Model Number	Order #	Overall Dimensions			Approx. Ship Wt
		Width	Length	Height	
		(in)	(in)	(in)	(lb)
ST-OPP-4248H36	1095700	48	42	36	200

Freight Class: 250



Streamline workflow and reduce manual labor with our line of Fork-Liftable Solutions

Keep your warehouses and distribution centers running smoothly with our durable, mobile equipment. Built for performance and reliability.

Watch our Video



FORK-LIFTABLE MOBILE ORDER PICKING TABLE

- Constructed of all welded steel, ensures durability and heavy duty use
- Powder coated gray
- Diamond steel top to prevent slipping
- Ergonomic raised platform prevents any physical strain on associates during order picking.
- Forklift pockets available from both sides
- Caged on three sides to prevent damage while allowing visibility of products
- Load Capacity per Deck: 1000 lbs
- Total Load Capacity: 2000 lbs

Model Number	Order #	Overall Dimensions			Approx. Ship Wt
		Width	Length	Height	
		(in)	(in)	(in)	(lb)
ST-OPP-4842H36-MLC	1154014	48	42	39	200

Caster Information:
 Swivel Plate Caster with 5" Polyurethane Wheel & Brake 738AW-LC (523055)
 Rigid Plate Caster with 5" Polyurethane Wheel 743W (523063)
 5" Polyurethane Wheel 7112 (122180)

Freight Class: 250



ST-OPP-4842H36-MLC

As part of our commitment to continuous product improvement, Winholt reserves the right to modify materials and specifications without prior notice.



DISTRIBUTION TOW CART

- Constructed of all welded steel
- Powder coated silver finish
- Shelves fold up and are held with slotted hinges.
- Option for (1) center divider on each shelf
- Tow hitch folds up when not in use
- Load Capacity:
 - Per Shelf: 500 lbs
 - Total: 1000 lbs
- Retractable sign holder can be used to label carts and destination locations.



Shelves easily fold up, sides fold and units can be nested for storage.

Handle Pull & Tow Hitch



DC-2852TOW-2S-SLV



Shown w/
Optional Dividers

Model Number	Order #	Overall Dimensions			Approx. Ship Wt (lb)
		Width	Length	Height	
		(in)	(in)	(in)	
DC-2852TOW-2S-SLV	1098417	28½	57 ⁷ / ₁₀	70 ⁹ / ₅	272

Caster Information:

Swivel Caster with 5" Polyurethane Wheel & brake 7318 (123051)
 Rigid Caster with 5" Polyurethane Wheel 7414W (608833)
 5" Polyurethane Wheel 7128 (122438)
Freight Class: 250

ON-LINE ORDER PICKING WORK STATION

- Constructed of all welded aluminum, powder coated red, lightweight and easily maneuvered
- Solid top offers additional working area
- Includes: printer basket, utility shelf, bag holder, label roll rod, paper towel holder
- Holds 6 lugs for order picking - approx. 22"L x 15¼"W x 10"H, not included
- Vinyl grip handles assist in maneuvering the cart with ergonomic design
- Weight Capacity: 40 lbs per tote
- Multifaceted order picking cart, loaded with features, an all in one work station to streamline the picking process and increase production.



ALTPC-2536-MO



Model Number	Order #	Overall Dimensions			Approx. Ship Wt (lb)
		Width	Length	Height	
		(in)	(in)	(in)	
ALTPC-2536-MO	1141967	25	41 ⁴ / ₅	48	52

Caster Information:

Swivel Plate Caster with 5" Polyurethane Wheel & Brake 738AW-LC (523055)
 Rigid Plate Caster with 5" Polyurethane Wheel 743W (523063)
 5" Polyurethane Wheel 7112 (122180)
Freight Class: 250



ALUMINUM LADDER CART

ALUC-3-2463H70-3SL



- All welded aluminum construction is lightweight and easier to maneuver around the warehouse
- Ladder is welded aluminum with bolted painted steel parts. Lifts up and locks for storage. Top safety latch and bottom gravity latch.
- Anti-slip grip tape on ladder steps.
- Handy utility box can hold accessories and tools required during picking.
- Holds 6 totes - approximately 21"L x 17"W x 17"H, sold separately
- Total Load Capacity: 600 lbs

Model Number	Order #	Overall Dimensions			Approx. Ship Wt
		Width	Length	Height	
		(in)	(in)	(in)	(lb)
ALUC-3-2463H70-3SL	-	24	71	76	130

Caster Information:
 (2) Rigid 5" x 2" Polyurethane
 (4) Swivel 5" x 2" Polyurethane with Brakes
Freight Class: 250



SC-3-2332-NHMLC-WM



Founded in 1946

LADDER CARTS

STEEL & ALUMINUM CONSTRUCTION



STEEL LADDER CART

- Welded steel construction cart with aluminum folding ladder.
- (3) Solid shelves, top shelf with a lip to prevent roll off.
- Ladder lifts up and locks when not in use.
- Anti-slip grip tape on ladder steps for safety.
- Two handles to push the cart also serve as safety guard when ladder is in use.
- Maneuvers easily on (2) 5" polyurethane swivel and (2) rigid casters

Model Number	Order #	Overall Dimensions			Approx. Ship Wt
		Width	Length	Height	
		(in)	(in)	(in)	(lb)
SC-3-2332-NHMLC-WM	1050229	24¾	60½	70¼/5	136

Caster Information:
 Swivel Plate Caster with 5" Polyurethane Wheel & Brake 738AW-LC (523055)
 Rigid Plate Caster with 5" Polyurethane Wheel 743W (523063)
 5" Polyurethane Wheel 7112 (122180)
Freight Class: 250



SC-3-2332-NHMLC-WM

U-BOAT PICKING & STOCK CART



16-60-6W-2SDR-PBX-KT

- Heavy duty steel construction, base diamond steel deck
- Two removable slanted shelves and high end handles
- Equipped with ladder holder bracket and bag hanger tabs.
- Powder coated aluminum gray
- Narrow 16" width deck
- Two center load wheels and four 4" swivel end casters
- Six wheel design allows cart to swivel on its own radius.
- Load Capacity: 200 lbs per shelf, 1000 lbs total

Model Number	Order #	Overall Dimensions			Approx. Ship Wt
		Width	Length	Height	
		(in)	(in)	(in)	(lb)
16-60-6W-2SDR-PBX-KT	1097027	16 ¹ / ₅	63 ³ / ₁₀	55	126

Caster Information:

Polyurethane Center Wheel 7417 (123351)
 Swivel Plate Caster 4" Polyurethane Wheel 7351 (123211)
 4" Polyurethane Wheel 7125 (122403)

Freight Class: 250



SLANTED SHELF PICKING CART



SC-2036H58-2S

- Cart has three shelves, two slanted at 10°
- Slanted shelves provide better access and greater visibility of items for order picking
- Chalkboard writing surface to ID merchandise and location
- Constructed of steel
- Powder coated gray
- Shelf Capacity: 200 lbs each

Model Number	Order #	Dimensions			Approx. Ship Wt
		Width	Length	Height	
		(in)	(in)	(in)	(lb)
SC-2036H58-2S	1070289	20	40	58 ² / ₅	155

Caster Information:

Swivel Plate Caster with 5" Polyurethane Wheel & Brake 738AW-LC (523055)
 Rigid Plate Casters with 5" Polyurethane Wheel 743W (523063)
 5" Polyurethane Wheel 7112 (122180)

Freight Class: 250





SC-2-2149-MO

TOW PICKING CART

- Constructed of all welded steel
- Powder coated gray
- Two solid shelves doubles the capacity, each supported by a tubular frame
- High end handles keep totes and merchandise in place
- Pull handle makes the carts easy to maneuver
- Chalkboard writing surface to ID merchandise and location
- Base Load Capacity: 1100 lbs

Model Number	Order #	Overall Dimensions			Approx. Ship Wt
		Width	Length	Height	
		(in)	(in)	(in)	(lb)
SC-2-2149-MO	1141970	21	50	71¾	145

Caster Information:

Swivel Caster with 5" Polyurethane Wheel 738AW (523039)
 Rigid Caster with 5" Polyurethane Wheel 743W (523063)
 5" Polyurethane Wheel 7112 (122180)

Freight Class: 250



MOBILE CAGED TRANSPORT CART



SSD-Cart-1

- This Mobile Caged Transport Cart securely moves merchandise. Caged on all four sides so you can view all enclosed merchandise.
- All welded steel construction, powder coated gray
- Steel wire sides with cluster punched steel sheet metal base
- Perimeter bumper protects fixtures.
- Four swing open doors as well as drop down gate for optimum access to merchandise
- Snap on grip handle
- Maneuvers easily on (2) 6" swivel polyurethane casters with brakes and (2) 6" with directional locks.

Model Number	Order #	Dimensions			Approx. Ship Wt
		Width	Length	Height	
		(in)	(in)	(in)	(lb)
SSD-CART-1	-	29 ³ / ₅	49 ⁴ / ₅	61 ⁴ / ₅	150

Caster Information:

Swivel Caster with 6" Polyurethane Wheel & brake 7326W-BK (630045)
 Rigid Caster with 6" Polyurethane Wheel 7417W (522618)
 6" Polyurethane Wheel 7129 (122446)

Freight Class: 250



PICKING SHELF CART

- Slanted shelves provide better access and greater visibility to items being picked.
- Aluminum tubular construction
- Aluminum utility box (23"L x 4"D x 5"W) holds accessories and tools required during picking, saving time and labor.
- Maneuvers easily on six wheel design, with ergonomic push handle
- Weight Capacity: 800 lbs

Model Number	Order #	Overall Dimensions			Approx. Ship Wt
		Width	Length	Height	
		(in)	(in)	(in)	(lb)
ALUC-3-2659-6W-SDR	1074010	26	69	68	39

Caster Information:

Swivel Caster with 5" Polyurethane Wheel & Brake 738AW-LC (523055)
 5" Polyurethane Wheel 743W (523063)

Freight Class: 250



ALUC-3-2956-6W-SDR

Holds a number of different bins, lugs and totes.

As part of our commitment to continuous product improvement, Winholt reserves the right to modify materials and specifications without prior notice.

PICKING SHELF CART

- Constructed of all welded aluminum - lighter in weight and easier to maneuver in aisles
- Lean solution for faster and accurate replenishment
- Ensures one-touch picking, saving time, labor and money
- Slanted shelves provide better access and greater visibility to items being picked.
- Raised lip on shelves ensure items are held securely in place
- Weight Capacity: 1000 lbs



Model Number	Order #	Overall Dimensions			Approx. Ship Wt
		Width	Length	Height	
		(in)	(in)	(in)	(lb)
AL-L-6-8PU	1075784	35 3/4	41 3/4	49 2/5	39

AL-L-6-8PU

Holds various containers or tubs

Caster Information:

Caster with 8" Polyurethane Wheel 7325 (123123)

5" Polyurethane Wheel 7416 (123342)

Freight Class: 250



ORDER PICKING CURBSIDE PICKUP DELIVERY CART

- Constructed of aluminum, light weight and easy to maneuver
- Features: writing utensil tray, paper bag holder, hooks for plastic bags - making for a perfect working station
- Bumpers prevent damage to store fixtures.
- Two shelf structure allows additional storage for totes.
- Weight Capacity: 400 lbs

Model Number	Order #	Overall Dimensions			Approx. Ship Wt
		Width	Length	Height	
		(in)	(in)	(in)	(lb)
Open Top					
ALMCS-36-224-RCUH-HF	999707	25	45 3/4	42	75

Caster Information:

Swivel Caster with 5" Polyurethane Wheel 738AW (523039)

Rigid Caster with 5" Polyurethane Wheel 743W (523063)

5" Polyurethane Wheel 7112 (122180)

Freight Class: 250



ALMCS-36-224-RCUH-HF



Put Your Store Logo Here



Bag Holder Hooks



Founded in 1946

MATERIAL HANDLING EQUIPMENT & WAREHOUSE STORAGE

U-Boats

Ladder Truck

Utility Cart

Stocking & Marking Carts

Wet Produce Carts

Hand Truck

Sani Stock Cart

Security Cages

Lockers

Locker Options

Work Stations

Receiving Desks

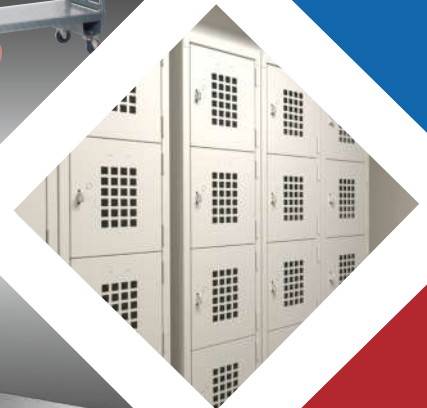



U-BOAT® DIAMOND STEEL DECK THE CLASSIC

- Narrow 16" width deck
- Constructed of all welded steel with anti-skid diamond plate steel deck.
- All models have two high-end, removable handles to secure merchandise in place.
- Maneuvers easily on two 8" stationary center load wheels and four 4" swivel end casters. Six wheel design allows cart to swivel on its own radius.

Polyurethane Wheels:
Heavy Duty Applications,
Long Life,
Low Maintenance,
& Non-Marking



**Maximize
Productivity!
Does the Work of
5 Hand Trucks!**



300-60D-PU



Model Number	Order #	Overall Dimensions			Capacity (lb)	Approx. Ship Wt (lb)
		Width (in)	Length (in)	Height (in)		
Utility Cart with Polyurethane Center & Polyurethane End Wheels						
300-48D-PU	100095	16	51	61	2000	81
300-60D-PU	100343	16	63	61	2000	95

Caster Information:

8" Polyurethane Center Wheel 7130 (122462)
Swivel Plate Caster w/ 4" Polyurethane Wheel 7351 (123211)
4" Polyurethane Wheel 7125 (122403)

Freight Class: 70

U-BOAT ACCESSORIES

GARMENT BAR

- This attachment converts our cart into a Garment Rack providing safe transportation of garments from shipment to warehouse to selling floor.
- This garment accessory offers you two carts in one!

Model Number	Order #	Use on Models
GR-60KD-RX	204548	300-60D-PU
4793	154448	Additional Race Fitting



ADDITIONAL REINFORCED REMOVABLE SHELVES

- Multiple shelves help you to organize your merchandise.
- Shelf capacity: 200 lbs
- 300 series can be supplied with one top removable shelf.
- (1) Welded middle shelf option available.

Model Number	Order #	Use on Models
AS-48	151001	300-48D-PU
AS-60	151010	300-60D-PU



BUMPER

Specify option by adding suffix to Diamond Steel Deck U-Boats.

Model Number	Order #	Use on Models
B	—	300-48D-PU 300-60D-PU

Freight Class: 150

FOLDING U-BOAT ALUMINUM

- Light weight, aluminum cart
- **Lifetime Warranty Against Rust**
- Handles fold for upright storage.
- Narrow 16" width, designed for use in busy aisles.
- Maneuvers easily on two 6" stationary center load wheels and four 5" polyurethane swivel end casters. Six wheel design allows cart to swivel within its own radius.



Model Number	Order #	Overall Dimensions			Capacity	Approx. Ship Wt
		Width (in)	Length (in)	Height (in)		
AL-300-60-FH	661407	16	63	60½	1500	50

Caster Information:

6" Polyurethane Center Wheel 7417 (123351)
Swivel Plate Caster w/ 5" Polyurethane Wheel 738A (128784)
5" Polyurethane Wheel 7112 (122180)

Freight Class: 70

As part of our commitment to continuous product improvement, Winholt reserves the right to modify materials and specifications without prior notice.



300-60D-SDR

U-BOAT WITH SLANTED SHELVES

- Great for overstock merchandise.
- Narrow 16" width deck
- Constructed of all welded steel, three slanted shelves with turned up lip to prevent run off.
- Convenient tool box
- Maneuvers easily on two 8" stationary center load wheels and four 4" swivel end casters. Six wheel design allows cart to swivel on its own radius.

Model Number	Order #	Overall Dimensions			Capacity	Approx. Ship Wt
		Width	Length	Height		
		(in)	(in)	(in)	(lb)	(lb)
300-60-SDR	268373	16	67	61	2000	130

Caster Information:

8" Polyurethane Center Wheel 7130 (122462)
 Swivel Plate Caster w/ 4" Polyurethane Wheel 7351 (123211)
 4" Polyurethane Wheel 7125 (122403)

Freight Class: 70

LADDER TRUCK



- All purpose truck is ideal for stocking, marking and reaching high shelves.
- Constructed of all welded steel with six wheel design for maximum maneuverability.
- Non-skid steps and handle bars assure secure grip and foot control.
- Maneuvers easily on four 5" swivel rubber and two 5" rigid rubber plate casters.

Model Number	Order #	Overall Dimensions			Capacity	Approx. Ship Wt
		Width	Length	Height		
		(in)	(in)	(in)	(lb)	(lb)
LT-2	126252	24	50	53	1000	140

Caster Information:

Rigid Plate Caster with 5" Rubber Wheel 743 (123422)
 Swivel Plate Caster with 5" Rubber Wheel 738 (123246)
 5" Rubber Wheel 718 (122690)

Freight Class: 250

Options:

BP-2 (180902)...Bumpers (2)

Stock Cart and Step Ladder all in one!



LT-2



ALUC-2-2036-36H

ALUMINUM UTILITY STOCK CART HEAVY DUTY

- Ideal cart for universal applications in all departments.
- Heavy duty channel construction, all welded aluminum construction
- Two shelf unit rolls easily on 5" polyurethane casters, two swivel and two rigid

Model Number	Order #	Overall Dimensions			Capacity	Approx. Ship Wt
		Width	Length	Height		
		(in)	(in)	(in)	(lb)	(lb)
ALUC-2-2036-36H	624251	20	40 ^{3/10}	36	1200	36

Caster Information:

Swivel Plate Caster with 5" Poly Wheel & Brake 738ABK (209185)
 Rigid Plate Caster with 5" Poly Wheel 743A (127892)
 5" Polyurethane Wheel 7112 (122180)

Freight Class: 250

STOCKING AND MARKING CARTS

- Constructed of all welded steel.
- Galvanized top shelf and bottom tubular shelf with a vertical upright frame design. Two bumpers on corners.
- Maneuvers on two 5" polyurethane swivel casters and two 5" polyurethane rigid plate casters.
- Weight Capacity: 700 lbs

Model Number	Order #	Overall Dimensions			Approx. Ship Wt
		Width	Length	Height	
		(in)	(in)	(in)	(lb)
WX-1000KA-B-WM	524971	20	42	40 ³ / ₈	61



WX-1000KA-B-WM

Caster Information:

Swivel Plate Caster with 5" Polyurethane Wheel 738A (128784)
 Rigid Plate Caster with 5" Polyurethane Wheel 743A (128792)
 5" Polyurethane Wheel 7112 (122180)

Freight Class: 100



**Easy grip handle.
 Ergonomic Design.
 Designed for Efficiency!**



Increase productivity!

STOCKING AND MARKING CART

- This stocking and marking cart is an excellent transporter for stockroom, shipping and selling floor. Bottom shelf increases capacity.
- Constructed of square, heavy duty, steel tube. Dark green powder coated finish. Ships set up ready to use.
- 18" width is ideal for narrow aisles.
- Rolls easily on two 5" swivel and two 5" rigid casters
- Weight Capacity: 600 lbs



Model Number	Order #	Overall Dimensions			Capacity	Approx. Ship Wt
		Width	Length	Height		
		(in)	(in)	(in)	(lb)	(lb)
110	126543	18	40	41	600	44

Caster Information:

Swivel Plate Caster with 5" Polyurethane Wheel 738A (128784)
 Rigid Plate Caster with 5" Polyurethane Wheel 743A (128792)
 5" Polyurethane Wheel 7112 (122180)

Freight Class: 250

STOCKING AND MARKING CART

- Constructed of all welded, steel frame with wire mesh top shelf and tubular bottom shelf. Powder coated silver finish.
- Carts roll easily on two 5" rubber swivel and two rigid casters.

Model Number	Order #	Overall Dimensions			Capacity	Approx. Ship Wt
		Width	Length	Height		
		(in)	(in)	(in)	(lb)	(lb)
9000-STK4	137533	18½	44	38 ⁴ / ₅	400	47

Caster Information:

Swivel Plate Caster with 5" Rubber Wheel 738A (128794)
 Rigid Plate Caster with 5" Rubber Wheel 743A (128792)
 5" Rubber Wheel 718 (122690)

Freight Class: 250



9000-STK4
 Powder Coated Finish

WET PRODUCE CARTS GALVANIZED STEEL AND ALUMINUM



WPT-2340

- This versatile wet produce cart, designed to handle wet items, is equipped with a removable and reversible pan to accommodate a variety of items.
- Model WPT-2340 constructed of galvanized steel.
- Model WPT-2340-AL-WM constructed of light weight aluminum with self-adhesive polypropylene bumpers.
- Weight Capacity: 600 lbs
- Maneuvers easily on two 5" swivel polyurethane and two 5" rigid polyurethane casters.

Model Number	Order #	Overall Dimensions			Approx. Ship Wt
		Width	Length	Height	
		(in)	(in)	(in)	(lb)
WPT-2340	126594	25	43 ¹ / ₅	41	100
WPT-2340-AL-WM	487947	25	43 ¹ / ₅	36	55

Caster Information for Model WPT-2340 :

Swivel Plate Caster with 5" Polyurethane Wheel 738AW (523039)
Rigid Plate Caster with 5" Polyurethane Wheel 743A (523063)
5" Polyurethane Wheel 7112 (122180)



Caster Information for Model WPT-2340-AL-WM :

Swivel Plate Caster with 5" Polyurethane Wheel 738A (128784)
Rigid Plate Caster with 5" Polyurethane Wheel 743A (128792)
5" Polyurethane Wheel 7112 (122180)

Freight Class: 250

Options:

BP-2 (180902)...Bumpers (2)

508SP-RD



STEEL HAND TRUCK

- Heavy duty steel pipe construction for tough jobs or standard duty steel tubular construction. Standard color is red.
- Heavy duty all welded reinforced plates - 8" depth x 14" width.
- Weight Capacity: 800 lbs
- 5 Year Frame Guarantee
- 10" Semi-Pneumatic Wheels

Model Number	Order #	Overall Dimensions			Wheel Type (5/8" Ball Bearing)	Approx. Ship Wt
		Width	Length	Height		
		(in)	(in)	(in)	(lb)	
Heavy Duty Steel Pipe Hand Truck						
508SP-RD	651701	19 ¹ / ₂	19 ¹ / ₂	46	10" Semi-Pneumatic	50

Caster Information:

10" x 2³/₄" Semi-Pneumatic Wheel - (SP) 714 (128768)

Freight Class: 150

ALUMINUM SANI STOCK CART T-BAR DECK HEAVY DUTY

- All welded, sanitary, T-bar aluminum design. Uprights and handles are secured in place by heavy duty, welded collars.
- **Lifetime Warranty Against Rust**
- Ideal cart for universal applications in all departments.
- Easily maneuverable on two 5" swivel plate and two rigid plate polyurethane casters.

Model Number	Order #	Overall Dimensions			Capacity	Approx. Ship Wt
		Width	Length	Height		
		(in)	(in)	(in)	(lb)	(lb)
T-Bar Deck						
TBST-1837	137411	18	41⁴/₅	37³/₁₀	300	30

Caster Information:
 Swivel Plate Caster w/ 5" Poly Wheel & Brake 738ABK (204185)
 Rigid Plate Caster w/ 5" Poly Wheel 743A (128792)
 5" Polyurethane Wheel 7112 (122180)
Freight Class: 250



**TBST-1837
T-Bar Shelf Decks**



EC-3-2448-2ADJ

SECURITY CAGES

- All welded steel construction for extra strength, powder coated silver, with steel mesh sides
- See through mesh keeps items visible at all times
- Push handle to assist with steering
- Two hinged doors with base and top locking mechanism with pad lock (sold separately) keeps merchandise secure.
- Unit has three shelves, two are adjustable on 1" increments with quick clips. Easily adjust the space between the shelves to accommodate a variety of items.
- Weight Capacity: 2000 lbs
- Maneuvers easily on two 6" swivel plate casters and two 6" rigid plate casters, two with brakes.

Model Number	Order #	Overall Dimensions			Approx. Ship Wt
		Width	Length	Height	
		(in)	(in)	(in)	(lb)
EC-3-2448-2ADJ	1051900	24	48	63	300
EC-3-2460-2ADJ	1048997	24	60	63	300

Caster Information:
 Swivel Plate Caster w/ 6" Phenolic Wheel & Brake 7311BK (211115)
 Rigid Plate Caster w/ 6" Phenolic Wheel 746 (123481)
 6" Phenolic Wheel 7119 (122331)
Freight Class: 250



As part of our commitment to continuous product improvement, Winholt reserves the right to modify materials and specifications without prior notice.

STEEL LOCKERS

- Multi-User steel lockers can be used in all types of facilities, and industries, perfect for any environment.
- All lockers open with door pulls and will accept padlocks (not included) for positive latching. Also can be used with flat key lock (not included).
- Doors are mesh grid vented for clear identification of personal items and security.
- All lockers have a replaceable box base attached at the factory. Bases prevent dirt, dust and debris from accumulating under the lockers keeping the locker area clean and reducing labor costs.
- Ships fully assembled, ready to use upon arrival.
- Select colors available. Standard is beige finish.
- Sequentially numbered labels provided for easy identification.



Select Colors Now Available!
See Page 127 for Color Chart



WL-618
3 Columns
18 Doors

2 DOOR LOCKERS

- Double the number of compartments in the same amount of floor space
- 34½" Locker length
- Each double column is equipped with a ceiling double-prong hook and side prong hooks to hang outerwear.
- 3 Column sets are pre-attached, fully assembled
- Beige finish
- Sequentially numbered labels provided for easy identification.

Model Number	Order #	Number Doors	Dimensions			Approx Ship Wt
			Width	Depth	Height	
			(in)	(in)	(in)	(lb)
2 Door, 1 Column						
WL-21	156216	2	12	12	78	52
2 Door, 3 Column						
WL-6	152864	6	36	12	78	156

Options:
ST Slanted Top



WL-21
1 Column
2 Doors



WL-55
1 Column
5 Doors

5 DOOR LOCKERS MULTI-TIER

- Steel single column lockers offer 5 door compartments.
- 12" deep lockers with perforated doors
- Enclosed base
- Ships fully assembled. Ready to use upon arrival.
- Beige finish
- Sequentially numbered labels provided for easy identification.

Model Number	Order #	Number Doors	Dimensions			Approx Ship Wt
			Width	Depth	Height	
			(in)	(in)	(in)	(lb)
5 Door, 1 Column						
WL-55	626433	5	12	12	66	45

Freight Class: 125

Options:
ST Slanted Top

EXPRESS
Ships in 2-3 Days!

6 DOOR LOCKERS MULTI-TIER

- Steel single column lockers offer 6 door compartments.
- 3 column sets are pre-attached, fully assembled, 18 door compartments
- Available in 12", 15", and 18" depths.
- Beige finish
- Sequentially numbered labels provided for easy identification.



WL-618
3 Columns
18 Doors

Model Number	Order #	Number Doors	Dimensions			Approx Ship Wt
			Width	Depth	Height	
			(in)	(in)	(in)	(lb)
6 Door, 1 Column						
WL-66	156195	6	12	12	78	63
WL-66-15	163862	6	12	15	78	69
WL-66-18	163918	6	12	18	78	71
6 Door, 3 Column						
WL-618	130358	18	36	12	78	172
WL-618-15	163854	18	36	15	78	211
WL-618-18	163900	18	36	18	78	234

Freight Class: 125

Options:
ST Slanted Top

EXPRESS
Ships in 2-3 Days!

4 DOOR LOCKERS HORIZONTAL WALL MOUNT

- Provides both coat storage and personal storage.
- Wall mounted steel locker provides personal storage for 4.
- Garment bar provides additional coat storage.
- Ships fully assembled, ready to use upon arrival
- Beige finish
- Sequentially numbered labels provided for easy identification.



WL-4
4 Doors with Garment Bar

Garment Bar
for Coat Storage

Model Number	Order #	Number Doors	Dimensions			Approx Ship Wt
			Width	Depth	Height	
			(in)	(in)	(in)	(lb)
4 Door, Horizontal Wall Mount Locker						
WL-4	156099	4	48	18	13 ⁵ / ₈	49

Freight Class: 175

GARMENT / 16 PERSON LOCKER

- Provides both coat storage and personal storage.
- Steel garment locker provides personal storage for 16.
- Garment bar provides additional coat storage.
- Ships fully assembled, ready to use upon arrival.
- Beige finish.
- Sequentially numbered labels provided for easy identification.

Model Number	Order #	# Doors	Dimensions			Approx Ship Wt
			Width	Depth	Height	
			(in)	(in)	(in)	(lb)
WL-16-CB	138253	16	72	18	78	193

Freight Class: 175

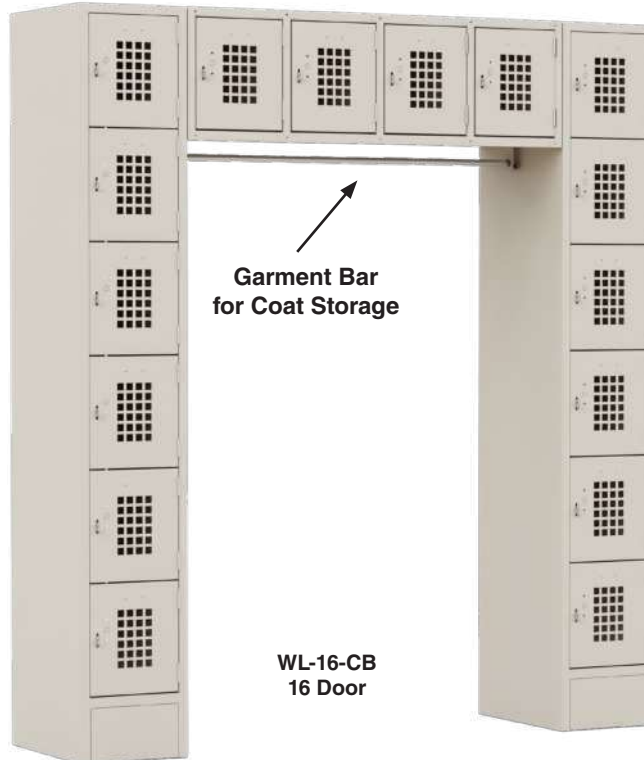

Garment Bar
for Coat Storage

WL-16-CB
16 Door

LOCKER OPTIONS

SLOPE TOP CROWN KIT - 3 COLUMN



- Maintains clean locker tops to meet sanitary health codes.
- 1 kit per 3 columns - Includes (3) slope tops, (3) back supports, and (2) end pieces
- Quick and easy installation.
- For factory installation, please contact our team at orders@winholt.com

Model Number	Order Number	Description
WLST-12	162376	Kit for 3 Columns - 12" Depth
WLST-15	165681	Kit for 3 Columns - 15" Depth
WLST-18	162384	Kit for 3 Columns - 18" Depth

Freight Class: 100



LOCKER NUMBERING

- Locker number labels are supplied one-up, consecutively. Number tags are shipped inside the locker compartment. Special numbering sequences are available at no extra charge. Include the required numbering with your order.
- **Use Order Number: 654784 for custom numbering sequence.**

LOCKER CUSTOM COLORS

- We offer select locker colors to choose from.
- Add the color chart suffix to the end of the locker model number when placing your order
- Lead time applies

Suffix	Color
Beige (Standard)	
-WH	White
-BL	Blue
-NBL	Navy
-RD	Red
-OR	Orange
-GN	Green
-BRN	Brown
-BK	Black
-FBK	Flat Black
-GY	Grey
-SLV	Silver

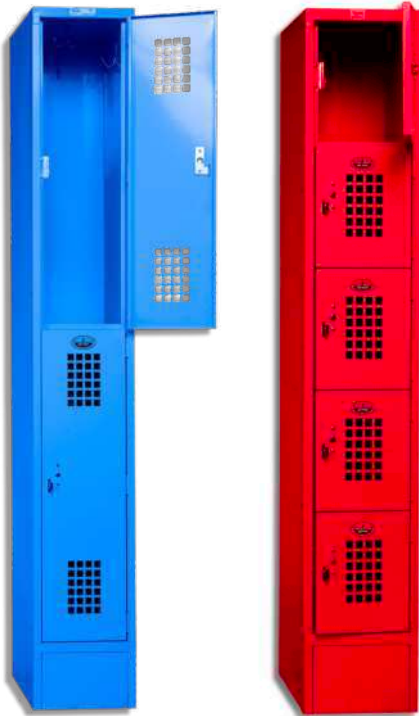

As part of our commitment to continuous product improvement, Winholt reserves the right to modify materials and specifications without prior notice.

STAINLESS STEEL WORK STATIONS

- These Multi-Use Work Stations create a computer desk, utility workspace, or storage space in any section of your facility.
- All welded stainless steel construction with (2) hinged doors and adjustable bullet feet.
- Create a computer desk space with convenient cable hole design.



WLFD-WRKSTN-1

Model Number	Order #	Overall Dimensions			Approx. Ship Wt
		Width	Length	Height	
		(in)	(in)	(in)	(lb)
WLFD-WRKSTN-1	1146955	24	30	43	127
WLFD-WRKSTN-2	1147172	24	36	80	188

Freight Class: 250



WLFD-WRKSTN-2

RECEIVING/SHOP DESKS STEEL & WIRE MESH

- Built to meet the needs of modern security standards
- Desk surface lifts up into a lockable storage compartment.
- Expanded metal enclosed sides and back with lockable expanded metal door and two storage shelves.
- Lockable desk top with open paper compartments above the locking writing surface
- Gray finish

Model Number	Order #	Color	Overall Dimensions			Approx. Ship Wt
			Width	Length	Height	
			(in)	(in)	(in)	(lb)
OTE-2224-GY	151968	Gray	22	22	49½	95



OTE-2224-GY

Caster Information:

Swivel Square Stem Caster with 5" Polyurethane Wheel 757 (123684)
 Swivel Square Stem Caster with 5" Polyurethane Wheel & Brake 757BK (206931)
 5" Polyurethane Wheel 7112 (122180)

Freight Class: 125



RECEIVING DESKS STEEL & STAINLESS STEEL

- Winholt Receiving Desks provide the perfect work station for receiving, record keeping and for inventory purposes.
- All models are ideally suited for receiving and shipping areas.
- Each model provides a large, solid writing surface with utility compartments.
- Table units offer a convenient undershelf.
- Choose from Wall Mount, Mobile or Stationary designs.
- Constructed of heavy duty steel or all welded stainless steel.
- Mobile units maneuver easily on four 5" heavy duty polyurethane swivel casters, two with brakes.



RDWNSS-1
Wall Mount



RDSWN-2
Stationary

Model Number	Order #	Type	Overall Dimensions			Approx. Ship Wt
			Width	Length	Height	
			(in)	(in)	(in)	
Steel						
RDWN-1	101371	Wall Mount	22 ³ / ₅	24	12 ¹ / ₂	30
RDSWN-2	101362	Stationary	22 ³ / ₅	24	45	45
RDMWN-3	101354	Mobile	22 ³ / ₅	24	49	57
Stainless Steel						
RDWNSS-1	152830	Wall Mount	22 ³ / ₅	24	12 ¹ / ₂	21
RDSWNSS-2	152848	Stationary	22 ³ / ₅	24	45	64
RDMWNSS-3	156081	Mobile	22 ³ / ₅	24	49	76
RDSWNSS-5	240688	Enclosed Stationary	32 ¹ / ₂	30	53	126

Caster Information for Model RDMWN-3 :

- Swivel Square Stem Caster with 5" Polyurethane Wheel 757 (123684)
- Swivel Square Stem Caster with 5" Polyurethane Wheel & Brake 757BK (206931)
- 5" Polyurethane Wheel 7112 (122180)

Freight Class: 85 (RDWN-1)

Freight Class: 200

Options:

472 (166641) Replacement Cylinder Lock & Key



Winholt receiving desks help keep your receiving and shipping areas organized.



RDMWN-3
Mobile

RDSWNSS-5
Stationary Enclosed



RECEIVING/SHOP DESKS STEEL

- All welded steel construction for extra strength.
- OT-78 Open frame with slanted writing surface and two undershelves.
- Standard color is beige.
- OTE-78 Enclosed solid sides and back with lockable doors.
- Slanted writing surface, with these storage shelves. Standard color is beige.
- Other colors available, upon request.

Model Number	Order #	Color	Overall Dimensions			Capacity	Approx. Ship Wt
			Width	Length	Height		
			(in)	(in)	(in)	(in)	(lb)
OT-78	101240	Beige	24	18	44	300	50
OTE-78	101282						83

Caster Information:

Swivel Square Stem Caster with 5" Polyurethane Wheel 757 (123684)
 Swivel Square Stem Caster with 5" Polyurethane Wheel & Brake 757BK (206931)
 5" Polyurethane Wheel 7112 (122180)

Freight Class: 125

Options:

HSP Hasp For OTE-78 & OTE-2224-GY



OTE-78



OT-78



As part of our commitment to continuous product improvement, Winholt reserves the right to modify materials and specifications without prior notice.

800.444.3595 | orders@winholt.com | www.winholt.com



Founded in 1946

HOME CENTER & GARDEN

- Steel Deck Cart
- Customer Wagon
- Customer Diamond Deck Cart
- Sheet Cart
- Customer Lumber Cart
- Adjustable 3 Tier Riser
- Steel Utility Cart



STEEL DECK CART

- A reliable solution for helping shoppers transport heavier items like bags of soil, mulch, or large planters with ease
- Steel construction
- Powder coated blue
- Reinforced handle
- Rear (2) swivel 6" polyurethane casters and front (2) rigid
- Weight Capacity: 2000 lbs
- Allows customers to easily maneuver heavy loads throughout the facility.

Model Number	Order #	Overall Dimensions			Approx. Ship Wt.
		Width	Length	Height	
		(in)	(in)	(in)	
2448PU	-	24	48	40	100
3060PU	117348	30	66 ⁷ / ₁₀	40	140



3060PU

Caster Information:

- (2) 6" x 2" Swivel Polyurethane Wheel Casters (Front Wheels)(CAS858-6)
- (2) 6" x 2" Rigid Polyurethane Wheel Casters (Rear Wheels)(CAS859-6)

Freight Class: 250

CUSTOMER WAGON

- Durable plastic wagon designed for shoppers to easily shop for plants, soil, and supplies around the store with comfort and efficiency.
- Plastic deck wagon for customers to easily transport plants.
- Powder coated blue deck
- Hexagon deck design to reduce build up, plastic design to prevent corrosion
- Weight Capacity: 1200 lbs

W-2437PL-BL



Model Number	Order #	Overall Dimensions			Approx. Ship Wt.
		Width	Length	Height	
		(in)	(in)	(in)	
W-2437PL-BL	-	24 ³ / ₅	40 ¹ / ₂	10 ¹ / ₂	50

Caster Information:

- (2) 6" x 2" Swivel Polyurethane Wheel Casters (Front Wheels)(CAS858-6)
- (2) 6" x 2" Rigid Polyurethane Wheel Casters (Rear Wheels)(CAS859-6)

Freight Class: 250

CUSTOMER DIAMOND DECK CART

- Customer deck cart with ergonomic handle and basket allows shoppers to transport both large and small products efficiently throughout the store.
- Basket dimensions: 10"W x 22"L x 9³/₄"H
- Heavy duty diamond deck prevents slipping, essential for heavy loading
- Ergonomic handle allows customers to easily maneuver cart between aisles
- Weight Capacity: 2000 lbs

WN-48D-6

Model Number	Order #	Overall Dimensions			Approx. Ship Wt.
		Width	Length	Height	
		(in)	(in)	(in)	
WN-48D-6-PU	-	29 ¹ / ₂	56	39	108

Caster Information:

- (2) 6" x 2" Swivel Polyurethane Wheel Casters (Front Wheels)(CAS858-6)
- (2) 6" x 2" Rigid Polyurethane Wheel Casters (Rear Wheels)(CAS859-6)

Freight Class: 250



SHEET CART

- A reliable solution for transporting sheets of material such as metal, plywood, or drywall
- Steel construction
- Rear (4) swivel 6" polyurethane casters and center (2) rigid 6" polyurethane core casters
- Bolted top frame with reinforced posts
- Weight Capacity: 600 lbs per shelf, 1200 lbs total
- 6" Casters provide smooth mobility for wide and heavy loads across retail floors



PT-3060-6W

Model Number	Order #	Overall Dimensions			Approx. Ship Wt.
		Width	Length	Height	
		(in)	(in)	(in)	(lb)
PT-3060-6W	-	30	60	30 ³ / ₁₀	100

Caster Information:

- (4) 6" x 2" Polyurethane Swivel Casters (CAS858-6)
- (2) 6" x 2" Polyurethane Rigid Casters (CAS859-6PS)

Freight Class: 250

Streamline store operations and enhance customer satisfaction with Winholt's dependable, high-performance solutions built for busy home improvement and garden centers.



3054HD4H-6W

CUSTOMER LUMBER CART

- Designed to hold large quantities for panels, molding, trim and hardware
- All welded steel construction
- 3 compartments, 4 handles
- Six wheel design make it easy for customers to maneuver full carts in busy stores.
- Weight Capacity: 2500

Model Number	Order #	Overall Dimensions			Approx. Ship Wt.
		Width	Length	Height	
		(in)	(in)	(in)	(lb)
3054HD4H-6W	-	30	54	48	122

Caster Information:

- (4) 5"x 2" Swivel Rubber Wheel Casters (End Wheels) (CAS858-6)
- (2) 6" x 2" Rigid Rubber Wheel Casters (Center Wheels) (CAS859-6PS)

Freight Class: 250

As part of our commitment to continuous product improvement, Winholt reserves the right to modify materials and specifications without prior notice.



ADJUSTABLE 3 TIER RISER

- Features two height-adjustable mesh tiers to reduce dirt buildup and accommodate various plant sizes, helping customers easily view and access merchandise.
- Constructed of all welded steel
- 16 gauge expanded powder coated gray caged metal shelves
- Shelf dimensions:
Bottom Shelf: 15.75"D
Top (2) Shelves: 14"D
- (2) Adjustable shelves, fixed middle tier
- Load Capacity per Shelf: 300 lbs



CMFC-4442

Model Number	Order #	Overall Dimensions			Approx. Ship Wt.
		Width	Length	Height	
		(in)	(in)	(in)	(lb)
CMFC-4442	1150572	42	44	36 ⁷ / ₈	125

Caster Information:
(4) 3" Swivel Polyurethane Wheel Casters with Brake
Freight Class: 250



240-48D-PU

STEEL UTILITY CART

- Maneuver heavy, large products smoothly with our steel utility carts
- Steel construction, powder coated gray
- Six wheel design allows for cart to move 3060 on it's axis. (4) swivel 4" end casters and (2) rigid 8" center casters
- Removable handles on both sides of unit
- Weight Capacity: 1500 lbs
- Heavy duty casters support heavy loads.
- Cart can be used for associates and customers to transport product

Model Number	Order #	Overall Dimensions			Approx. Ship Wt.
		Width	Length	Height	
		(in)	(in)	(in)	(lb)
240-48D-PU	534002	24	51	60 ³ / ₁₀	110
240-60D-PU	655111	24	60	60 ³ / ₁₀	120

Caster Information:
(8" Polyurethane Center Wheel 7130 (122462)
Swivel Plate Caster w/ 4" Polyurethane Wheel 7351 (123211)
4" Polyurethane Wheel 7125 (122403)
Freight Class:



Founded in 1946

SMALLWARES & ACCESSORIES

Platters & Trays

Bagel, Bread and Bun Baskets

Bagel Boards

Cutting Boards & Replacement Poly Tops

Merchandise Display Stand

Lugs

Stack and Nest Containers

Rack Covers

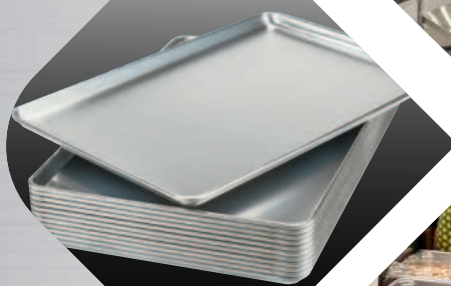

PLATTERS AND TRAYS

- Constructed of injection molded, super high-impact polystyrene with extra ribbing for rigidity and extra strength.
- Reinforced front and side edges provide additional impact resistance.
- Sanitary, safe edged, fingertip grip design. All smooth surfaces for easy cleaning.
- We offer three materials, all with reinforced front and side edges.
- Seamless construction of sanitary, white polystyrene - resists the corrosive attacks of food and meat acids, strong detergents and temperature changes.

Model Number	Order #	Overall Dimensions			Color	Case Quantity	Approx. Ship Wt
		Width	Length	Height			(lb)
		(in)	(in)	(in)			
WHP-1826WH	111843	18	26	1	White	24	3.5
WHP-1826WABS	111835	18	26	1	White	24	3
WHP-1826GABS	111819	18	26	1	Green	24	3
AP-1826	107991	18	26	1	Aluminum	12	3

Freight Class: 85

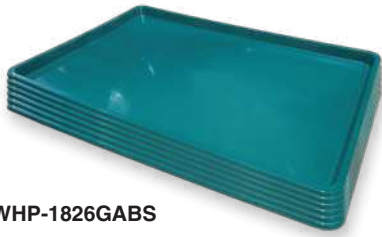

WHP-1826GABS



WHP-1826WABS



AP-1826

SANI-PLATTERS

- Constructed of injection molded, super high-impact polystyrene with extra ribbing for rigidity and extra strength. Reinforced front and side edges provide additional impact resistance.
- Seamless construction of sanitary, white polystyrene resists the corrosive attacks of food and meat acids, strong detergents and temperature changes.



WHP-1230

Model Number	Order #	Overall Dimensions			Case Quantity	Approx. Ship Wt
		Width	Length	Height		(lb)
		(in)	(in)	(in)		
WHP-1030	104117	10	30	¾	12	2
WHP-1224	104125	12	24	¾	12	2.4
WHP-1230	104141	12	30	¾		

Freight Class: 85



UPS and the UPS trademark are trademarks that are used with permission by the owner, United Parcel Service of America, Inc. All rights reserved.

BAGEL, BREAD, AND BUN BASKETS

- For displaying, storing, and transporting bulk baked goods
- Heavy duty, nickel chrome wire
- Allows customers to see full selection of bagels and rolls

Model Number	Order #	Description	Overall Dimensions						Approx. Ship Wt	
			Width		Length		Height		(lb)	(kg)
			(in)	(mm)	(in)	(mm)	(in)	(mm)		
WSBB1118	207714	Chrome Basket, Slant Top	11	279	18½	457	8	203	4	2



WSBB1118

Freight Class: 85



BAGEL BOARDS

- High-impact polystyrene bagel boards.
- Perfect for proofing bagels.
- Heavy duty, easy to clean plastic. Will not rot or mildew.



BB1826

Model Number	Order #	Overall Dimensions			Approx. Ship Wt
		Width	Length	Height	
		(in)	(in)	(in)	(lb)
BB1826	208021	18	26	5/16	4

Freight Class: 60



CUTTING BOARDS & REPLACEMENT POLY TOPS

- Sanitary, ¾" and 5/8" thick replacement poly tops and poly cutting boards are dishwasher safe and high-temperature safe to 180°F
- Can be steam cleaned without concern about cracking or warping
- Poly will not chip, peel nor dull knives.
- All poly top cutting boards and table tops are NSF listed and USDA approved for contact with any type of food.
- Special order sizes and thicknesses available upon request.



Poly Top

Model Number	Order #	Overall Dimensions		Approx. Ship Wt
		Width	Length	
		(in)	(in)	(lb)
Poly Top - 5/8" (16mm) Thickness				
PT58-1218	253446	12	18	4
PT58-1520	250026	15	20	6
Poly Top - ¾" (19mm) Thickness				
PT34-1218	192268	12	18	6
PT34-1520	253471	15	20	12
PT34-1836	146157	18	36	11
PT34-2430	127706	24	30	21
PT34-3036	146018	30	36	28

Freight Class: 70

Options:

311-033 (218544) Stainless Steel Clips for Poly Tops





MERCHANDISE DISPLAY STANDS DOUBLE & SINGLE

- Material: All welded, plated, heavy duty steel wire
- Maximizes product visibility and enhances customer impulse buying
- Elevates products off the ground allowing the area underneath to be cleaned for more sanitary conditions.
- Nests for storage and freight savings

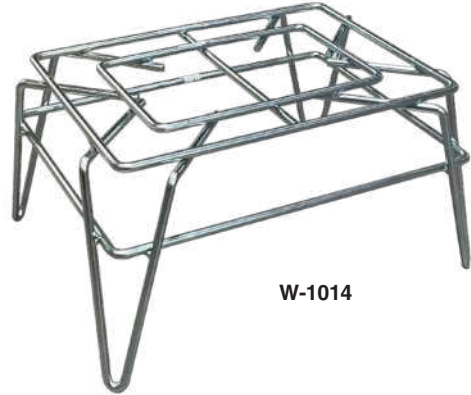

W-1014

Model Number	Order #	Overall Dimensions			Capacity	Approx. Ship Wt
		Width	Length	Height		
		(in)	(in)	(in)		
W-1014	108231	10	14	8	500	5
W-2414	624366	14	24	8	850	8

Highlights products and merchandise in aisle.

Use multiple units along an aisle to increase impulse sales.

Freight Class: 125

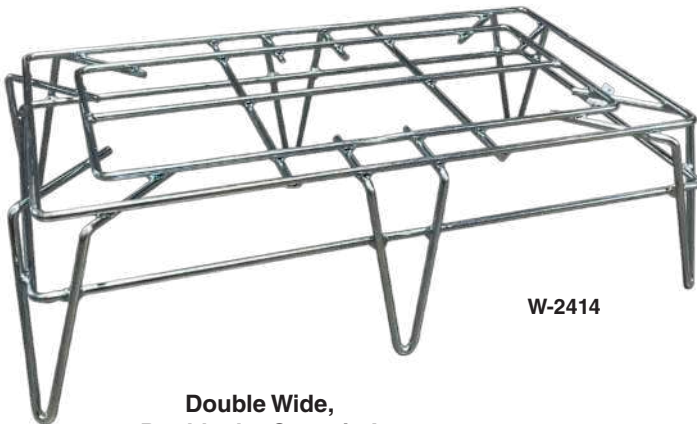

W-2414

Double Wide,
Double the Capacity!



Display Stands stack when not in use, saving valuable floor space!

LUGS

- Ideal for transporting and storing all types of products including warm or cold, food processing, preparation, etc. Compatible with other brands.
- High density, polyethylene lugs will not rust or dent. USDA approved material. Smooth interior and wide radius corners for easy cleaning. Built-in handles.
- 1.3 cu. ft. capacity holds up to 100 lbs
- 4:1 Nesting ratio saves space and reduces handling of empties. Lugs are designed to prevent jamming.
- Available in Gray, White, Red and Blue

Model Number	Order #	Overall Dimensions			Color	Approx. Ship Wt
		Width	Length	Height		
		(in)	(in)	(in)		(lb)
Lug – Polyethylene						
WHPL-8GY	104432	16	25	8	Gray	3
WHPL-8WH	104459	16	25	8	White	3
WHPL-8RD-RC	643225	16	25	8	Red	3
WHPL-8BL-RC	643233	16	25	8	Blue	3
Lids – Polyethylene						
WHPL-8LID-GY	138608	16	25	1	Gray	3
WHPL-8LID-WH	128979	16	25	1	White	3

Freight Class: 70



AL-L-1

See our line of
Lug Carts on Page 88



WHPL-8GY
& WHPL-8LID-GY



SN-2618
Stacked

STACK AND NEST CONTAINERS

- Designed for a long life of rugged use, the Stack and Nest Container improves efficiency and productivity in any department.
- Perforated lugs have perforations along the bottom of the lug to allow for draining
- The uniform thickness and design gives maximum strength and protection to your goods. Built-in rim handles and a polyethylene material makes this product easy to handle. USDA approved material.

Model Number	Order #	Color	Overall Dimensions			Approx. Ship Wt
			Width	Length	Height	
			(in)	(in)	(in)	(lb)
Solid						
SN-2618	104424	Gray	19	26	11	7
SN-2618GN	1090271	Green	19	26	11	7
Perforated						
SN-2618PERF	177316	Gray	19	26	11	7
SN-2618PERF-GN-PBX	1090280	Green	19	26	11	7

Freight Class: 70



SN-2618GN

In line with our policy to continually improve our products, Winholt reserves the right to change materials and specifications without notice.



SRC-58-3Z

BAKERY RACK COVER

- Made of heavy duty, clear plastic cover with 3 reinforced zippers.
- Transparent plastic makes it easy to identify products.
- Protects products during transport while preserving freshness.
- Prevents dehydration and enhances proofing.

Model Number	Order #	Overall Dimensions			Approx. Ship Wt
		Width	Length	Height	
		(in)	(in)	(in)	(lb)
SRC-58-3Z	112483	23	28	61	3

EXPRESS Ship
Ships in 2-3 Days!



Ensures food stays safe during transport and protects against freezer burn!



FREEZER RACK COVER

- Made of heavy duty, reinforced blue vinyl with 3 reinforced zippers. Withstands freezer temperatures down to -20°F.
- Transparent plastic front panel makes it easy to identify products.
- Protects products during transport while preserving freshness.
- Prevents dehydration and enhances proofing.

Model Number	Order #	Overall Dimensions			Approx. Ship Wt
		Width	Length	Height	
		(in)	(in)	(in)	(lb)
SRC-58FC-3Z	157041	23	28	64	5

All Freight Class: 77.5

EXPRESS Ship
Ships in 2-3 Days!



SRC-58FC-3Z





Founded in 1946

REPLACEMENT PARTS & WHEELS

Film Wrapper Parts

Heater Proofer Parts

Wheels & Casters



Thermostat



Thermostat Knob



Circuit Board



Cut-off Rod

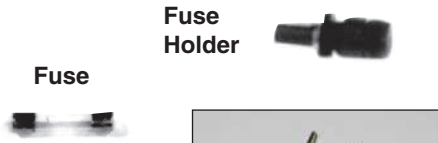

Fuse

Fuse Holder

Lighted Rocker Switch



Hot Plate with Heating Element

Heating Element



Core Adapter / Wing Unit



Teflon Cover

FILM WRAPPING MACHINE REPLACEMENT PARTS



100% Pre-Tested!

Winholt offers a complete line of high quality replacement parts for all wrapper models. Our parts are fully compatible with other popular brands.

Model Number	Order #	Description of Parts	Dimensions
WHSS-CBD-A	695885	Circuit Board - E4 & E5 terminals for connecting wires	2½" x 2½"
WHSS-COR-A	687025	Cut-Off Rod - heats film to precise, necessary temperature	7/16" x 23"
WHSS-TM	113267	Thermostat - regulates heat for the hot plate	½" x ½" x 2¼"
WHSS-TK	113259	Thermostat Knob	¼" I.D.
WHSS-FUS1	113152	Fuse	9/32" x 1¼"
WHSS-FHD	113144	Fuse Holder	¼" x 1¼"
WHSS-HP6	113161	Hot Plate with Heating Element - seals film securely	6" x 15"
WHSS-TC6	113232	Teflon Cover - for hot plate	6" x 15"
WHSS-E	113128	Heating Element - for hot plate	9/32" x 11¼"
WHSS-A	113056	Film Axle - aluminum film core axle	¾" x 22"
WHSS-CAP	113081	Core Adapter Pin Unit	3" I.D. Roll
WHSS-CAW	113099	Core Adapter Wing Unit	3" I.D. Roll-Threaded
WHSS-RS	113224	Lighted Rocker Switch	1¼" x ½"
WHSS-BB	113072	Bearing Blocks - regulates film tension	Bearing Blocks
WHSS-PR	135087	Plate Retainers - holds element to hot plate	4" x 11½"
WHSS-EWC	113136	Electric Wire	Per Foot

Freight Class: 70

Electric Wire



Film Axle



Bearing Blocks

UPS and the UPS brandmark are trademarks that are used with permission by the owner, United Parcel Service of America, Inc. All rights reserved.

800.444.3595 | orders@winholt.com | www.winholt.com

HEATER PROOFER REPLACEMENT PARTS

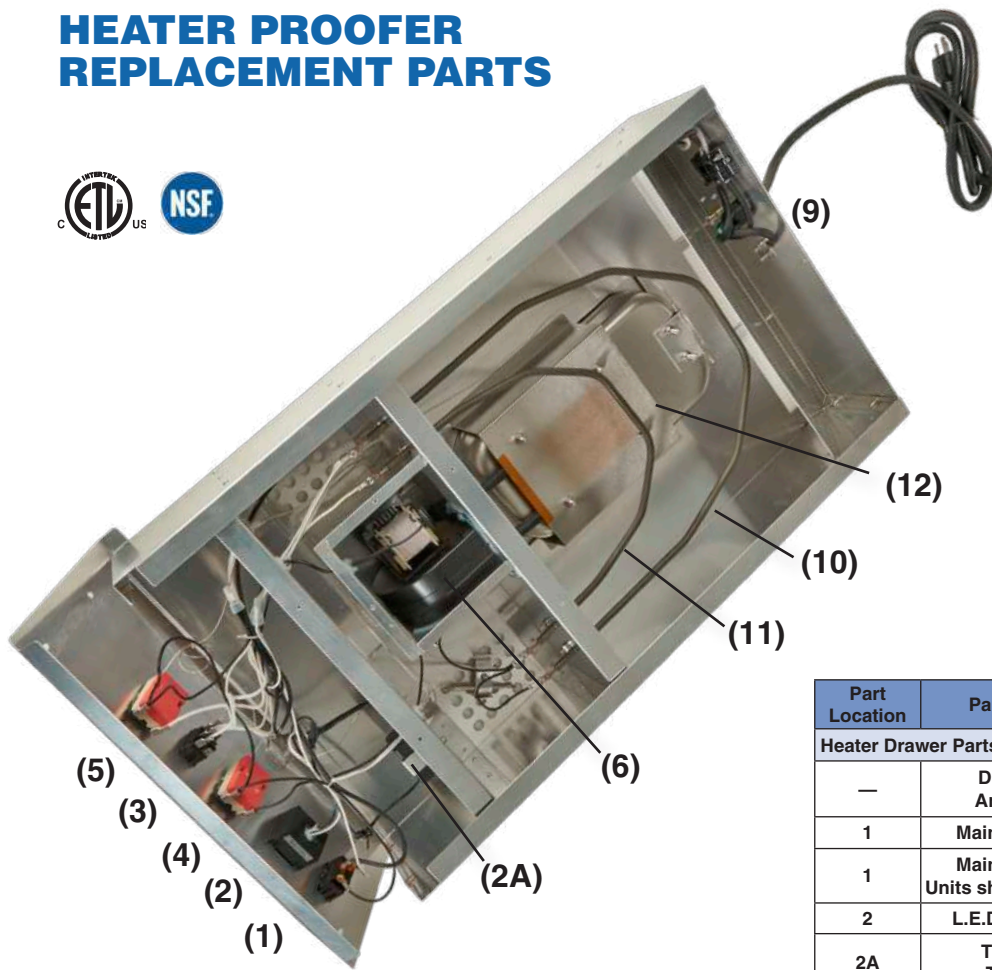

Drawer view from upside down with bottom cover removed.

*Removable Drawers
Makes Cleaning Quick & Easy*

**HEATER PROOFER
POWER SUPPLY
120VAC 60Hz
13.5 AMP**

Part Location	Part Description	Order #	Model #
Heater Drawer Parts List			
—	Digital Drawer Analog Drawer	1069296 631208	NHP-PD-DGT NHP-PD-ECO
1	Main Power Switch	637108	H-106-2B
1	Main Power Switch Units shipped after 5.2013	987124	H-106-2C
2	L.E.D. Thermometer	123887	H-105
2A	Thermometer Transformer		
3	Heat/Proof Switch	232784	H-106-1
9	Power Inlet	123908	H-107
4	Thermostat (Heat)	170851	H-220
5	Thermostat (Proof)		
6	Blower & Motor Assembly	637095	H-225-B
10	900W Heater Element	170907	H-226
11	600W Heater Element	170915	H-227
12	600W Water Pan Heater Element	170923	H-228
12A	Water Pan w/studs	696482	H-242
13	Heat Control Knob	123916	H-108
14	Proofer Control Knob		
15	Circuit Breaker	1081691	H-249
---	External Drip Pan	683665	WHPP6122.5D
Replacement power cord available at local home improvement stores			
Cabinet Parts List			
Replacement Door Lexan 1836 Series		247505	NHPL-DR
Replacement Universal Runner (1)		657150	NHPL-1825-UN-RUNNER
Door Gasket for NHPL-1810HHC		681416	NHPL-1810/HH-DR GSKT
Door Gasket for NHPL-1825UNC		681328	NHPL1825-UN-DR GSKT
Door Gasket for 1836 Series		650484	NHPL1836-DR GSKT
Replacement Door Lexan Universal Runner		657459	NHPL-DR/UN
Replacement Door Lexan Mini Half Height		657432	NHPL-DR/HH
Plastic Door Handle		233656	H-323-2

*Air baffle and circulating air
blower provide even heat
distribution.*

NHP-PD-ECO
Analog Drawer

Water Pan (12A)

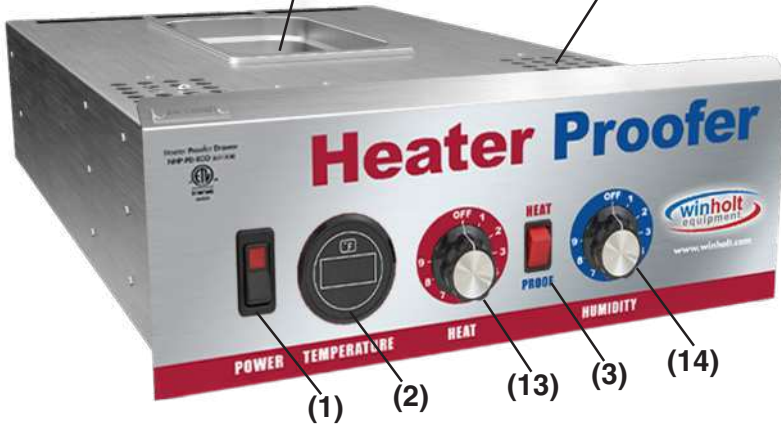

NHP-PD-DGT
Digital Drawer



Freight Class: 70

WINHOLT WHEELS & CASTERS

Wheel Terms

This diagram represents a basic wheel assembly. This might vary from wheel to wheel. Please consult the wheel specifications.

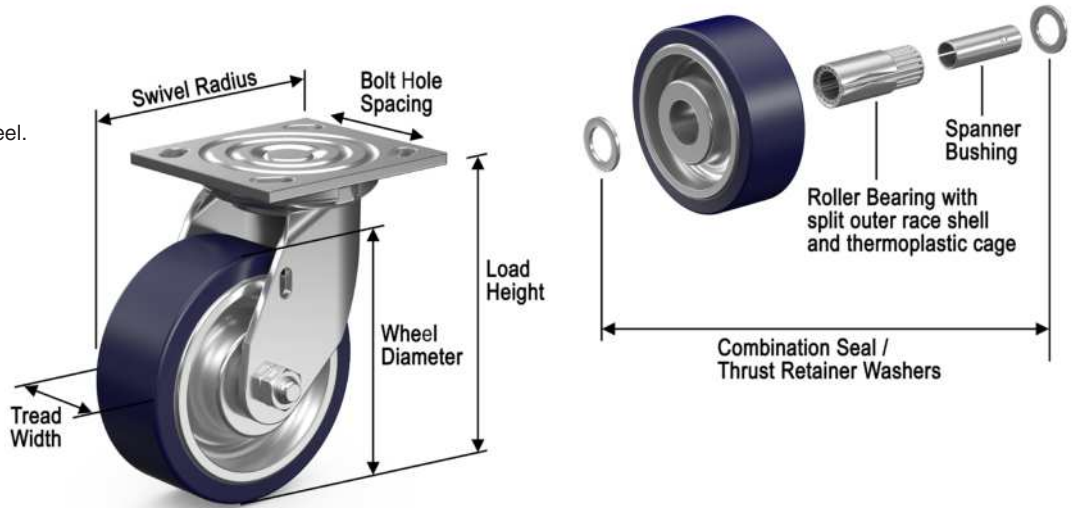

Choosing a Caster

Load Capacity - Load capacity can be described as the maximum rolling capacity of the equipment based on what you will place on that equipment. **Load capacity per caster** can be determined using this simple formula:

$$\text{Load Capacity} = \frac{\text{(Cart Weight + Maximum Load Placed on Cart)}}{\text{Number of Casters on Cart}}$$

Example: $75 + 800 / 4 = 219$ lbs per caster

We advise using your maximum load that might be used on the cart and not the average weight. The greater the weight the larger the wheel size should be to distribute the weight evenly. Always buy a caster with a higher rating than the load capacity formula. In our example of 219 lbs per caster, you should go with a caster of at least 250 lbs rolling capacity.

Proper maintenance and safety guidelines will extend the life and performance of your wheels. These easy to follow tips will assist you in achieving this goal.

1. Lubricate regularly, under normal conditions, approximately every six months. However, once a month may be warranted for applications in corrosive or wet conditions.
2. Check tread wear & swivel assemblies.
3. Do not roll at high speeds or on rough surfaces.
4. Do not exceed loads over the specified capacities.

Floor Surfaces											Easy Reference Wheel Selection Guide				Operating Conditions									
Carpet	Brick	Concrete	Linoleum	Asphalt	Terrazzo	Wood	Smooth Steel	Ribbed Steel	Tile	Wheel Type	Capacity of each	Temp Range	Durometer Ratings	Water	Steam	Mild Chemicals	Oil & Grease	Metal Chips	High Heat (+250°F)	Extreme Cold (-45°F)	Animal Fats	Noise Reduction	Floor Protection	Cushion Load
											(lb)	(Fahrenheit)												
•	•	•	•	•	•	•	•	•	•	Polyurethane	150-1000	-30° to +180°	95(±5)A	•	•	•	•	•	•	•	•	•	•	•
•	•	•	•	•	•	•	•	•	•	Solid Soft Rubber	75-400	-30° to +160°	75(±5)A	•	•	•	•	•	•	•	•	•	•	•
•	•	•	•	•	•	•	•	•	•	Solid Hard Rubber	100-500	-30° to +160°	75(±5)D	•	•	•	•	•	•	•	•	•	•	•
•	•	•	•	•	•	•	•	•	•	Polyolefin	100-850	-20° to +180°	65(±5)D	•	•	•	•	•	•	•	•	•	•	•
•	•	•	•	•	•	•	•	•	•	Mold-On Polyurethane	425-4200	-30° to +180°	55(±5)D	•	•	•	•	•	•	•	•	•	•	•
•	•	•	•	•	•	•	•	•	•	Mold-On Rubber	200 / 1700	-30° to +160°	75(±5)A	•	•	•	•	•	•	•	•	•	•	•
•	•	•	•	•	•	•	•	•	•	Phenolic	400 / 8000	-45° to +250°	85(±5)D	•	•	•	•	•	•	•	•	•	•	•
•	•	•	•	•	•	•	•	•	•	Phenolic High Temp.	400 / 2900	-45° to +475°	85(±5)D	•	•	•	•	•	•	•	•	•	•	•
•	•	•	•	•	•	•	•	•	•	Pneumatic	300-800	-20° to +160°	—	•	•	•	•	•	•	•	•	•	•	•
•	•	•	•	•	•	•	•	•	•	Semi-Pneumatic	150-450	-20° to +160°	—	•	•	•	•	•	•	•	•	•	•	•
•	•	•	•	•	•	•	•	•	•	Semi-Steel	200 / 3000	-45° to +250°	—	•	•	•	•	•	•	•	•	•	•	•

WHEELS



Polyurethane



Phenolic



Polyolefin



Mold-On Rubber

PLATE CASTERS

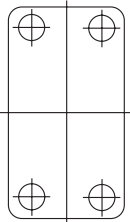

Wheel Dimensions	Material	Bearing	Wheel Model #	Swivel Caster Model #	Rigid Caster Model #	Rolling Cap. per Wheel	Temp. Range	Hardness Rating
Plate Dimensions 3 1/8" x 4 1/8"								
4" x 1 1/4"	Polyurethane	Ball	7125	7351W	7418	275 lbs	-30 to +180	95(+/-5)A
4" x 1 1/4"	Rubber	Nylon		732		225 lbs	-30 to +160	75(+/-5)D
5" x 1 1/4"	Polyurethane	Ball	7112	738AW	743W	400 lbs	-30 to +180	95(+/-5)A
5" x 1 1/4"	Rubber	Nylon		738		200 lbs	-30 to +160	75(+/-5)D
5" x 1 1/4"	Polyolefin	Plain		739		300 lbs	-20 to +180	85(+/-5)D
Plate Dimensions 4" x 4 1/2"								
2" x 1"	Mold-On Rubber	Cage Roller		731			-30 to +160	75(+/-5)A
3" x 1 1/4"	Polyurethane	Cage Roller		7317W	749W		-30 to +180	95(+/-5)A
4" x 1 1/2"	Phenolic	Cage Roller	71181				-45 to +250	85(+/-5)D
5" x 2"	Mold-On Rubber Polyurethane	Cage Roller		7310CBZ		1000 lbs	-30 to +180	55(+/-5)D
5" x 2"	Mold-On Rubber	Cage Roller			745CBZ	375 lbs	-30 to +160	75(+/-5)A
5" x 2"	Polyurethane	Cage Roller		7318	7414W	250 lbs	-30 to +180	95(+/-5)A
6" x 2"	Mold-On Rubber	Cage Roller	711	7324CBZ	7462CBZ	410 lbs	-30 to +160	75(+/-)A
6" x 2"	Phenolic	Cage Roller		7311BK	746	1200 lbs	-45 to +250	85(+/-5)D
6" x 2"	Polyurethane	Cage Roller	7129	7326	7417	800 lbs	-30 to +180	95(+/-5)A
8" x 2"	Mold-On Rubber	Cage Roller	712	7316		500 lbs	-30 to +160	75(+/-)A
8" x 2"	Phenolic	Cage Roller				1400 lbs	-45 to +250	85(+/-5)D
8" x 2"	Polyurethane	Cage Roller	7130	7325W	7416W	900 lbs	-30 to +180	95(+/-5)A

Freight Class: 65

STAINLESS STEEL CASTERS

Wheel Dimensions	Material	Caster Model #	Caster Type
5" x 2"	Polyurethane	743WSS	Rigid
5" x 1 1/4"	Polyurethane	757SS	Swivel Square Stem
5" x 1 1/4"	Polyurethane	757EXP-SS-1	Stem Caster, Expendable
6" x 2"	Polyurethane	7417S	Rigid
4" x 1 1/4"	Polyurethane	7351WPH-SS	Swivel
5" x 1 1/4"	Polyurethane	738AWSS	Swivel

Freight Class: 65



Swivel Casters

As part of our commitment to continuous product improvement, Winholt reserves the right to modify materials and specifications without prior notice.

STEM CASTERS

Square Stem
 $27/32"$ x $2\frac{1}{2}"$ with $13/64"$
 or $13/32"$ hole $1\frac{1}{4}"$ above
 upper cup.



Round Stem
 $3/16"$ x $1\frac{9}{16}"$ with two
 cross drilled
 $5/16"$ holes.



Wheel Dimensions	Wheel Material	Bearing	Wheel Model #	Swivel Stem Caster Model #	Rigid Stem Caster Model #	Rolling Cap Per Wheel	Temp Range	Hardness Rating
Round Stem								
5" x 1 $\frac{1}{4}"$	Polyurethane	Ball	71121	7548	7537	500 lbs	-30 to +180	95(+/-5)A
Square 13/64 Stem								
5" x 1 $\frac{1}{4}"$	Polyurethane	Ball	7112W	757W		400 lbs	-30 to +180	95(+/-5)A
5" x 1 $\frac{1}{4}"$	Polyolefin	Plain		751		300 lbs	-20 to +180	85(+/-5)D
Threaded Stem								
5" x 1 $\frac{1}{4}"$	Polyurethane	Plain	71121			500 lbs	-30 to +180	95(+/-5)A

7322



OVEN RACK CASTERS - HIGH TEMP PHENOLIC WHEELS

- Molded macerated fabric with phenolic resin plastic.
- This hard tread wheel is designed for heavy load capacities and offers easy mobility over smooth surfaces and floor protection.
- The operation of the wheel is quieter than steel wheels and is resistant to most chemicals.
- High Temp Wheels are ideal for oven racks! Wheel includes bearing.

Wheel Model #	Wheel Color	Swivel Plate Caster Model #	Diameter (in)	Tread Width (in)	Bearing	Load Height (in)	Swivel Radius (in)	Cap. (lb)
Stainless Steel Caster								
71181	Brown	7322WSS	4	1 $\frac{1}{2}$	Nylon	6 $\frac{1}{4}$	6	600
7322PH	Green	7322PH	4	1 $\frac{1}{2}$	Steel	5	5 $\frac{1}{10}$	200

Caster Information:
 Stainless Steel Rig 7322SS (342852)
Freight Class: 65



714

HAND TRUCK WHEELS

- Model 714 is a semi-pneumatic solid rubber tire on a steel wheel disk. Maneuvers easily on all surfaces. Wheel includes bearing.
- Model 715 is a Mold-On Rubber tread locked to an aluminum core.

Wheel Model	Wheel Type	Diameter (in)	Tread Width (in)	Bearing	Axle Size (in)	Hub Length (in)	Cap. (lb)
715	Mold-On Rubber	8	1 $\frac{5}{8}$	Ball	5/8	2	450
714	Semi-Pneumatic	10	2 $\frac{3}{4}$			3	

Freight Class: 65



715



Founded in 1946

ORDERING TERMS & WARRANTY

General Ordering Information

Conditions of Sale

Statement of Warranty



GENERAL TERMS AND CONDITIONS OF SALE

Acceptance: Orders become binding upon Winholt only when accepted by our Customer Care Team. A representative or dealer is not authorized to bind orders.

Orders accepted by Winholt cannot be cancelled without written approval and are subject to a 20% cancellation fee. Cancellations are not accepted on orders in transit or on custom equipment in production. Winholt will not be held responsible for discrepancies on custom equipment once drawings have been approved and signed off by the customer. Customers are accountable for ensuring the accuracy of all specifications prior to production.

New Accounts: Please submit three (3) credit references, a bank reference with telephone number and contact person along with your Dun & Bradstreet number. We also require your Federal ID number or owners social security number and a copy of your Sales Tax Exemption Certificate wherever applicable. Allow three (3) to five (5) days to process your credit approval. For information concerning your credit status, please e-mail AR@winholt.com or call accounting at 516.222.0335.

Terms: Net thirty (30) days on open accounts from the date noted on the invoice. Open accounts will only be established upon receipt of satisfactory credit references.

Prices: All prices, specifications and discounts are subject to change without prior notice. Overall dimensions are as listed and these dimensions are nominal. The latest price list supersedes all other lists and any previously printed price materials. Prices are F.O.B. factory and do not include federal, state or other sales related taxes. Possession of the price list does not constitute an offer to sell. A freight surcharge may be imposed on shipments made out of our distribution centers.

Tax: Any tax or other governmental charge upon production, sale and/or shipment of goods, now imposed by federal, state or municipal authorities, or subsequently becoming effective, will be added to the price provided and will be paid by the buyer unless a completed and signed tax exemption certificate for appropriate state(s) is provided to Winholt.

Freight/Routing: Method of shipment will be determined by Winholt unless otherwise directed. When Winholt routes your order, per your request all units will ship at the standard freight class as determined by the carrier based on the weight & dimensions of the final shipment. Freight class listed in the catalog may not apply.

Damaged, Shortages and Lost Shipments: For shipments FOB Shipping point: Winholt will not be responsible for merchandise damaged in transit. All merchandise will be provided to carrier in good condition. All shipments should be inspected immediately upon receipt and any damage must be reported to the carrier at that time. For freight damage and loss in transit, it is the buyer's responsibility to file a freight claim against the carrier. Keep all concealed damaged goods and shipping containers for later inspection. For shipments FOB Destination: Winholt selected carrier service. All shipments must be inspected immediately upon receipt and any damaged merchandise must be notated on the POD and refused at time of delivery. All concealed damages and/or shortages must be reported to Winholt Customer Care Team within 48 hours of delivery. Winholt will not be responsible for any concealed damages or shortages not reported within 48 hours after delivery. All claims for damages and shortages notated on the POD will be processed by Winholt. Winholt reserves the right to request damaged merchandise to be returned to our facility for inspection prior to any credit being issued for the merchandise. Shortages: Shortage claims will not be considered unless Winholt Customer Care Team is notified within 48 hours after receipt of shipment.

Returns: To return merchandise, you must receive a return merchandise authorization number from the Winholt Customer Care team. Merchandise is to be returned with transportation charges pre-paid and is subject to a minimum 30% restocking fee. Any return product shipped FOB Shipping Point will be refused to the carrier and all returns without a Winholt RMA# notated on the shipper's paperwork will be refused to the carrier.

Customer Care Team: For information about our products or orders placed you may call our Customer Care Team toll free at 800.444.3595 between the hours of 8:00 a.m. and 5:00 p.m. CST, Monday thru Friday, or e-mail us at customerservice141@winholt.com

Parts Service/Warranty Claims: For parts service information or warranty questions, please call our Customer Care Team toll free at 800.444.3595 between the hours of 8:00 a.m. and 5:00 p.m. CST, Monday thru Friday, e-mail us at customerservice141@winholt.com. Be sure to have the following information available:

- o Model Number
- o Name of Dealer
- o Serial Number
- o Installation Date

How To Order: Send P.O. to:

- o orders@winholt.com
- o If you have questions call 800.444.3595

When placing an order, please provide us with complete information on your purchase order:

- o Purchase Order Number
- o Complete Bill To Address
- o Contact Name & Phone #
- o Winholt Payment Terms
- o Winholt Model # & Price
- o Desired Delivery Date
- o Specify Freight Carrier, if desired, on collect or 3rd party shipments
- o Quotation Date and Number (if applicable)

(Note: If freight carrier is not specified, Winholt will specify.)

Minimum Orders: \$2,500, an additional Ship/Handling fee for all drop shipped orders/shipments of \$50 per order.

Bids & Quotations:

- o Email sales@winholt.com

Large custom specifications can take between 24-48 hours. Quotations are valid for thirty (30) days from the date of quotation, unless otherwise noted on the quote.

Express Ship: Express Ship items typically ship in 2-3 days, subject to availability and order quantity. Winholt reserves the right to modify item availability or discontinue the program at any time.

Credit Card Purchases: We accept MasterCard, Visa and American Express. For credit card usage a convenience fee of 4.5% applies.



STATEMENT OF WARRANTY

All Winholt equipment, aluminum, plastic, steel and stainless steel, is guaranteed to be free from defects in materials and workmanship for one (1) year from the date of shipment from the Winholt Facility.

The warranty does not apply to equipment, which has been subject to accident, alteration, abuse, misuse, improper installation, maintenance or storage and adverse weather conditions. It excludes Custom Stainless Steel Fabrication projects covered under separate warranty.

Extended Warranty on Aluminum and Stainless Steel

Winholt Equipment Group provides a lifetime guarantee against rust or corrosion on all aluminum and stainless steel products for the period of time that the original purchaser owns the product. This guarantee is in effect provided that the product is used solely for its intended purpose, is cleaned and maintained periodically within accepted industry standards, and is cleaned with a cleaning agent generally accepted by the industry and in accordance with the label directions of the cleaning agent used.

Winholt Power Equipment Warranty

Winholt warrants to the initial purchaser that all Winholt power equipment, including but not limited to Heater Proofers and Film Wrappers be free from defects in material or factory workmanship, under ordinary use for the purpose for which it is designed, for a period of (1) year from the date of shipment from the Winholt facility. Equipment will, at our option, be repaired or have replacement part(s) furnished F.O.B. our factory. Warranty includes one (1) year labor from date of said shipment.

Return of component parts will not be accepted for credit without prior authorization of our Customer Care Department and then contingent upon our inspection. Warranty will not apply if, after examination, Winholt finds that the equipment or any part thereof was found defective through lack of purchaser's responsibility for maintenance or storage, shipping damage, accidental damage by moving or otherwise, improper voltage, misapplication or alteration by anyone other than ourselves, or use of unauthorized parts. Warranty does not apply to glass, plastic, light bulbs, gaskets, or heater elements.

Prior to any service agency performing warranty labor, Winholt's Customer Care Department must be contacted to provide a "Service Authorization" (SA) number. Winholt assumes no responsibility for any charges that were not expressly authorized by it or for any charges that exceed in Winholt's sole judgement, normal and customary amounts. If service is required during overtime the difference between overtime and standard labor rates shall be paid by the purchaser. Warranty does not apply if payment has not been received for the equipment at the time a claim is made or if the Winholt serial number has been removed.

Warranty Exclusions and Limitations: Warranty applies only within the United States, equipment outside the United States shall have parts coverage only.

Administration of Warranty

For assistance in filing a claim, contact Winholt 's Customer Care Department at 800.444.3595. Hablamos Español. All claims must be filed in writing and can be sent via: e-mail to customerservice141@winholt.com or mailed to Winholt Equipment, 1169 North Great Southwest Parkway, Grand Prairie, Texas 75050, Attention: Customer Care Department. If deemed necessary by Winholt, the product must be returned to a Winholt factory designated by Winholt, at the owner's expense for inspection and approval of the claim.

This warranty supersedes any other warranties implied or expressed. Warranty will not apply if purchaser is delinquent in payment of the equipment at the time claim is made or if our serial number has been removed from the equipment. Except as herein above set forth no other warranty is made. This warranty being exclusive and in lieu of all other warranties, expressed, implied or statutory, including without limitation implied warranties of merchantability or fitness. In no event shall the Company be liable for any delay in the performance of this warranty due to causes beyond its control. The Company shall in no event be liable for any consequential; special or contingent damages for breach of warranty or otherwise.

*As part of our commitment to continuous product improvement,
Winholt reserves the right to modify materials and specifications without prior notice.*

A WIDE RANGE OF SOLUTIONS.

A WORLD OF POSSIBILITIES.

Winholt offers a wide range of solution-based quality equipment and custom design capabilities that improve cost-efficiency, provide our customers with a national supply chain advantage, and deliver high-quality materials. As a leading U.S. manufacturer with a global supply chain, Winholt blends innovation, sleek design, and exceptional functionality—empowering businesses with versatile solutions and limitless potential to enhance their operations. ■ ■



Founded in 1946



Founded in 1946

*Our People
Make the Difference.*

20 Crossways Park Drive North
Suite 205
Woodbury, New York 11797

t: 800.444.3595

f: 800.844.4191

e: sales@winholt.com

w: www.winholt.com

New York • Pennsylvania • Texas • California



Connect with us to stay in touch.

