

TM A

Continuous-feed Food Processor



TM A
Unit only, please choose plates

- Stainless steel and aluminum construction
- Convenient continuous-feed operation
- 300 RPM plate speed from a powerful 3/4 Hp fan-cooled motor
- Ideal speed and precise cut to reduce oxidation for better results and longer shelf life
- Up to 500 Lb. of fresh produce per hour
- Double Interlock on feed hopper and product pusher for a safe and continuous-feed operation
- Interlocked cover and pusher, preventing the machine from operating if lid is not in place.

Features

Technical:

- Ideal plate speed, the blades do not damage the product, giving it attractive and unblemished shape
- Product drops directly in the collecting container without being pushed out, preserving its shape.
- The ejector blade avoids the accumulation of food inside the disc slot
- Slotted drop-in drive
- Two feed chutes for different sized-products
- The wide selection of cast-aluminum discs and grids feature hardened and stainless steel knives
- Feed hopper designed also to continuously process long and/or thin products

Safety:

- One interlock stops the machine when the lever is lifted.
- A second interlock prevents the machine from starting if cover is not in place.

Sanitary:

- The stainless steel and aluminum construction is easy to clean, do not stain or crack.
- The design allows for easy accessibility and cleanability.
- The food ejector blade is removable for cleaning of the disc place.
- Easy disc removal for quick and accurate cleaning.

Specifications

Operation:	Continuous feed, cut product drops into the container by gravity.
Construction:	Base is polished aluminum, motor shell is stainless steel.
Discs:	Aluminum with stainless steel blades.
Hopper opening sizes:	Main opening is semi-round with maximum dimensions of 6 1/4" x 3" (160 mm x 76 mm). Feed-opening for long-shaped products has a 2" (50 mm) diameter.
Yield:	350 to 500 Lb. per hour (depending of product being processed)
Motor:	0.75 Hp (515W), belt-driven, fan cooled, with thermal circuit breaker.
Electrical:	120V AC, 60Hz, 3.7 Amp. (220V, 50Hz available on request).
Plug & Cord:	Attached, flexible, 3 wire SJT AWG 16, 6'4" long. NEMA 5-15 P
Controls:	Rocker thermal circuit breaker with undervoltage.



Certified to UL Standard 763 and NSF Standard 08
 Certified to CSA Standard C22.2

Available discs



Chute for continuous product ejection, with safety microswitch.



Discs holder

Model NO. Thickness Recommended use

Slicing

DF 1	1/16"	Carrots, onions, mushrooms, cucumbers and other
DF 2	5/64"	Carrots, onions, mushrooms, cucumbers and other
DF 3	1/8"	Carrots, onions, mushrooms, cucumbers and other
DF 4	5/32"	Carrots, onions, mushrooms and other
DF 5	3/16"	Tomato and ripe vegetables
DF 8	5/16"	Carrots, onions, mushrooms, cucumbers and other
DF 10	3/8"	Carrots, onions, mushrooms, cucumbers and other
DF 14	9/16"	Carrots, onions, mushrooms, cucumbers and other

Julienne

DQ 4	5/32"	Carrots, potatoes, zucchini and other
DQ 6	7/32"	Carrots, potatoes, zucchini and other
DQ 8	5/16"	Carrots, potatoes, zucchini and other
DQ 10	3/8"	Carrots, potatoes, zucchini and other

Julienne PIRANHA

DQ 4 P	5/32"	Carrots, potatoes, zucchini and other
DQ 6 P	7/32"	Carrots, potatoes, zucchini and other
DQ 8 P	5/16"	Carrots, potatoes, zucchini and other
DQ 10 P	3/8"	Carrots, potatoes, zucchini and other

P = Piranha blades designed to guarantee a firm, precise cut from the first moment they contact the product

Grating & Shredding

DTV	1/16"	Hard cheeses, dry fruit, bread
DT 2	5/64"	Mozzarella, cheddar, vegetables
DT 3	1/8"	Mozzarella, cheddar, vegetables
DT 4	5/32"	Mozzarella, cheddar, vegetables
DT 7	9/32"	Mozzarella, cheddar, vegetables
DT 9	11/32"	Mozzarella, cheddar, vegetables

Dicing

PS 8	5/16"	Potatoes and similar (works with DF 8)
PS 10	3/8"	Potatoes and similar (works with DF 10)
PS 14	19/16"	Potatoes and similar (works with DF 14)
PS 20	13/16"	potatoes and similar (works with DF 14)

DISC HOLDER RACK Holds up to 5 discs

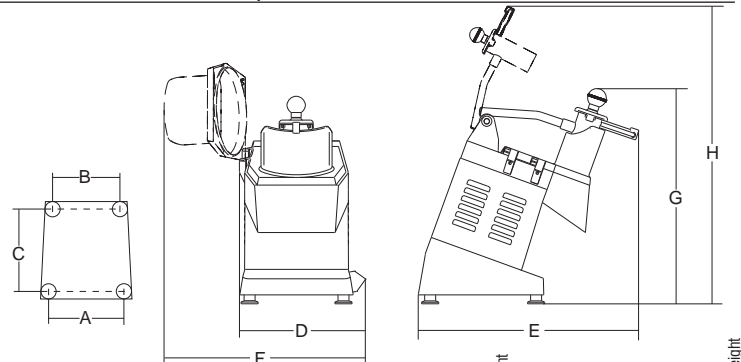

	Power	Power source	Disc revolutions	A	B	C	D	E	F	G	H	Net weight	Shipping	Gross weight
	watt/Hp		r.p.m.	inch.	inch.	inch.	inch.	inch.	inch.	inch.	inch.	lbs.	inch.	lbs.
TM A	515/0,7	120V AC, 60Hz, 4.29 A	300	8 ^{7/8} "	7 ^{11/16} "	10 ^{1/16} "	11"	20 ^{1/16} "	15 ^{3/4} "	20 ^{1/16} "	30 ^{5/16} "	41	29" x 14" x 20"	49