

Project Name: _____ Item #: _____ Quantity: _____

COMMERCIAL COOKING CARTS/ CABINETS

**BOH Series Convection Oven
Induction Range Cart, 2600W**

| | |
|-------------------|---|
| SKU | BOH-2600100 |
| EQUIPMENT | 2600W MAX Induction, 4 Zones FC100 Convection Oven |
| DIMENSIONS | 40”H x 36”W x 36”D |
| MATERIAL | 304 Stainless Steel |
| WEIGHT | 350 lbs. |



DESCRIPTION

Add power of induction to your back-of-house operation - our BOH Series Flameless Cooking Induction Carts offer cleaner, more efficient & safer cooking, prepping, and warming over traditional gas ranges. The built-in, full-size convection oven offers high-capacity, consistent baking for a variety of items.

Designed for maximum performance in a compact footprint, perfect for commercial kitchens looking to add efficient, quality cooking/ baking to their operation.

CERTIFICATIONS

- FCC
- ETL
- ETL-Sanitation to NSF-4
- UL-197
- ENERGY STAR Certified Induction

FEATURES

- 4-zone, 2600W MAX Induction Cooktop, ENERGY STAR CERTIFIED
- FC100 Roller Grill Convection Oven
- Durable, easy-to-clean stainless steel body
- Individually mounted controls
- Knurled knob for better grip & control
- Durable, 5” stainless-steel backsplash
- Interior power management system
- Front, bottom, & back ventilation
- Rear cooling fan to protect induction ranges or oven from overheating
- Recessed 5” swivel casters with brakes
- Made to order in the USA of domestic and foreign parts

ELECTRICAL REQUIREMENTS

Each unit includes a pre-wired Power Management System (PMS) to power the induction ranges with a single cord and plug. The convection oven base requires a separate connection.

| MODEL | PHASE | WATTS | VOLTAGE | AMPS | HERTZ | PLUG |
|---------|--------|-------|----------|---------|-------|-------------|
| PM-2466 | Single | 11kW | 208-240V | 60 AMPS | 50-60 | NEMA 14-60P |
| FC-100 | Single | 6kW | 208-240V | 29 AMPS | 50-60 | NEMA 6-50P |

CONSTRUCTION

INDUCTION COOKTOP

- ENERGY STAR Certified, 2600 W, 208-240V, 10.8 amps, 50-0 Hz (SM-261R x 4)
- Integrated PM-2466 PMS, 4 protected outlets manages cords & power to ranges and fan
- Durable 5 mm thick, easy to clean, tempered glass top
- 100% silicone rubber protective top seal
- Removable mesh air filter
- Simple, solid state controls
- 'Cook' mode, Power level 1-20
- 'Temp' mode, range 110 F- 400 F (43 C- 204 C)

CONVECTION OVEN

- Two speed rear mounted fan motor for greater baking variety
- Reversing turbine fan for uniform baking
- Manual steam feature for crusting of bread
- Thermostatically controlled up to 570F degrees
- Cool-to-the-touch double glass door and interior lights
- All stainless steel construction
- Capacity: (4) full size sheet pans (not included)
- Equipped with (4) wire shelves

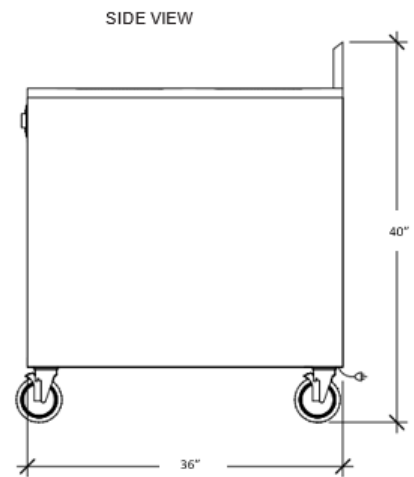
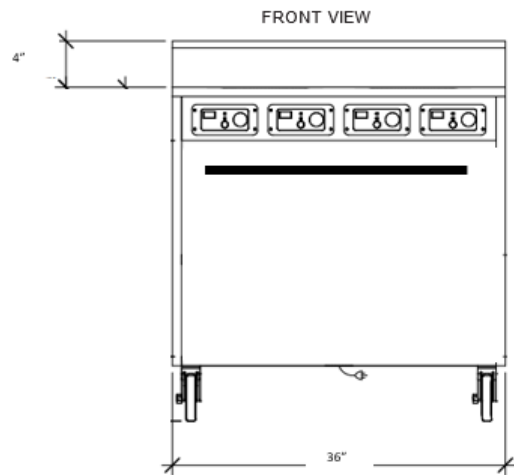

SIDE VIEW

SHIPPING DIMENSIONS

| LENGTH | WIDTH | HEIGHT | WEIGHT | UOM |
|--------|-------|--------|----------|--------------|
| 45" | 37" | 39" | 535 lbs. | Single Crate |

*Estimated crate dimensions, sizes may vary.