

SU444-12 SOFT SERVE/SHAKE PRESSURE FED TWO FLAVOR FLOOR MACHINES

DESCRIPTION

High capacity, combination soft serve/shake pressure freezer with refrigerated mix storage cabinet. Allows the operator to serve soft serve from the left side and shakes on the right, with the cost and convenience of one unit. Two compressors and two motors provide continuous production from each cylinder. Clear door shows moving product.

INTELLITEC2™ CONTROL FEATURES

- Programmable through a multi-line graphics display.
- Upload firmware and download statistics through USB port.
- Performance and error logs provide data to maximize profitability.
- Control senses product consistency or temperature to customize for a wide variety of mixes.
- Standby and sleep modes conserve energy and automatically defrost product, maintaining small ice crystals and delivering a superior mouthfeel.



Every machine includes Stoelting's White Glove Service. One call does it all – customer service, technical service, parts or warranty information, installation, startup, sales, on-site service dispatch and much more. Available 24 hours a day, seven days a week year-round.

ITEMS

- SU444-3812** Air cooled, single phase
- SU444-30912** Air cooled, three phase
- SU444-1812** Water cooled, single phase
- SU444-10912** Water cooled, three phase

ACCESSORIES

- 2208100 Stainless Steel Bag Adapter

FEATURES

- NSF approved food grade plastic blades provide quiet operation and superior durability.
- Simplified design for quick assembly after cleaning.
- Clear door displays circulating product for merchandising appeal.
- Efficient freezing cylinder and auger design delivers a consistent uniform product with small ice crystals and a quick recovery time.
- Highly efficient auger design gently folds the entire contents of the freezing cylinder, delivering a thick, smooth, and creamy product.
- Allows the operator to dispense smooth soft serve from the left side, and thick creamy shakes on the right side, with the convenience and cost of one unit.
- Dispensing and mixing product is accomplished with a single front-mounted handle for fastest speed of service.
- Pump approved for clean-in-place, reducing cleaning time and labor requirements.
- Mix containers in the refrigerated storage cabinet safely hold up to 16 gallons of mix, providing enough product during peak times and reducing the frequent refills.
- Long-wearing parts offer lower preventative maintenance costs.
- Tamper-proof controls for self-serve applications.
- Reliable and quiet with the combination of Stoelting's evaporator system and the Scroll™ compressor.
- Mix pumps inject the exact amount of air into your mix, maintaining overrun to ensure maximum profitability.

Continuous research leads to ongoing product improvements; therefore, these specifications are subject to change without notice and should not be used as installation specifications.

Approvals	Date

SU444-12 SOFT SERVE/SHAKE PRESSURE FED TWO FLAVOR FLOOR MACHINES

DIMENSIONS

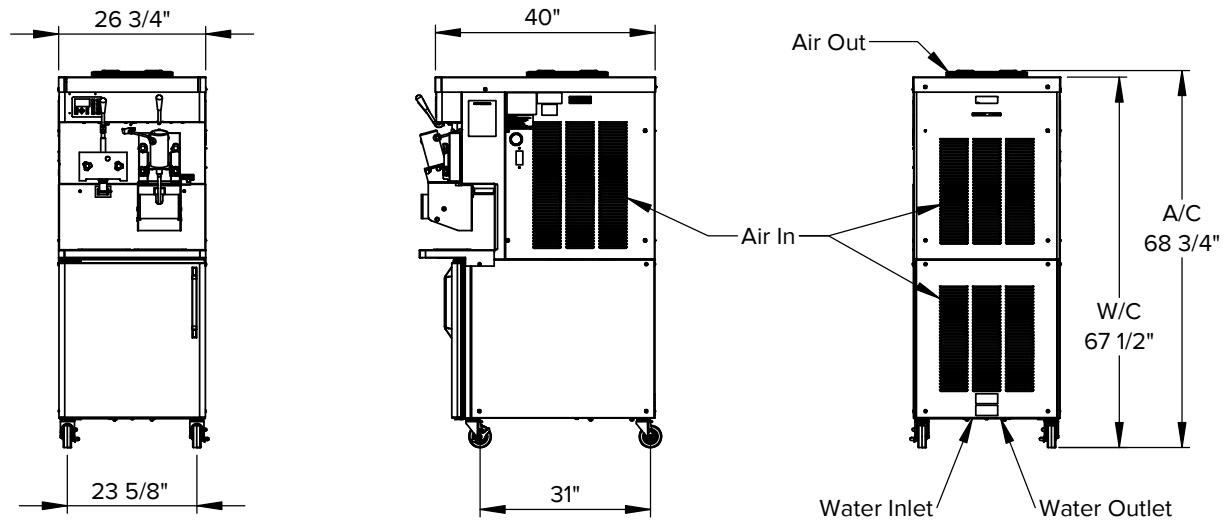

Height dimensions may vary ±1" due to casters

GENERAL SPECIFICATIONS

Machine Side	Freezing Cylinder				Cabinet				Drive Motor (hp)	Weight lb (kg)	Crated Weight lb (kg)
	Capacity gallon (L)	Compressor			Capacity gallon (L)	Compressor					
		Btu/hr	Refrigerant	Charge (oz)		Btu/hr	Refrigerant	Charge (oz)			
Soft Serve (Left Side)	1.33 (5.0)	19,000	R-448A	A/C: 48 W/C: 38	16 (60.5)	1,300	R-134a	8	2	760 (344.7)	930 (421.8)
Shake (Right Side)	2.1 (8.0)	15,000	R-448A	A/C: 46 W/C: 36					3/4		

- Indoor use only
- Maximum ambient temperature: 100°F (37.8 °C)
- Requires one dedicated electrical circuit per barrel
- Electrical plug not included. Hardwired connection required.
- Air cooled units require: Minimum clearance of 6" (15.2 cm) air space on all sides and open at the top
- Water cooled units require: 1/2" N.P.T. water and drain fittings. Maximum water pressure of 130 psi. Minimum water flow rate of 3 GPM per barrel. Ideal EWT of 50°-70°F. Minimum clearance of 6" (15.2 cm) air space on all sides.
- Details on CAD Revit Symbols Libraries are available on stoelting.klccad.com

ITEM NUMBER SPECIFICATIONS

Model Number	Cooling	Phase	Volts	Hz	Soft Serve (Left Side)		Shake (Right Side)	
					Minimum Circuit Ampacity (Amps)	Maximum Overcurrent Protection Device (Amps)	Minimum Circuit Ampacity (Amps)	Maximum Overcurrent Protection Device (Amps)
					SU444-3812	Air	1	208-240
SU444-30912	3	21.8	30	21.7	30			
SU444-1812	Water	1	208-240	60	33.3	50	28.8	40
SU444-10912		3			21.8	30	21.7	30



Service Information
 800-319-9549 (U.S. Toll Free)
 920-894-2293 (Outside the U.S.)
www.stoeltingfoodservice.com
www.vollrath.com