



Project:

Item Number:

Quantity:

U431-I2 SOFT SERVE PRESSURE FED FLOOR MACHINES



DESCRIPTION

Twin twist, pressure fed, soft serve machine with refrigerated mix storage cabinet. Ultra high-production capacity with two compressors and two drive motors allows you to serve two individual flavors or combine them for a twist. Produces quality product consistency from first cone to last. Ideal choice for restaurants, schools, cafeterias, drive-ins, recreational facilities and ice-cream parlors.

INTELLITEC2™ CONTROL FEATURES

- Programmable through a multi-line graphics display.
- Upload firmware and download statistics through USB port.
- Performance and error logs provide data to maximize profitability.
- Control senses product consistency or temperature to customize for a wide variety of mixes.
- Standby and sleep modes conserve energy and automatically defrost product, maintaining small ice crystals and delivering a superior mouthfeel.



Every machine includes Stoelting's White Glove Service. One call does it all – customer service, technical service, parts or warranty information, installation, startup, sales, on-site service dispatch and much more. Available 24 hours a day, seven days a week year-round.

Continuous research leads to ongoing product improvements; therefore, these specifications are subject to change without notice and should not be used as installation specifications.

ITEMS

Single Phase	Three Phase
Air Cooled	
U431-38I2	U431-309I2
	U431-309I2-SH
Water Cooled	
U431-18I2	U431-109I2
U431-18I2-SH	U431-109I2-SH
Remote Air Cooled	
U431-48I2	U431-409I2
U431-48I2-SH	U431-409I2-SH

ACCESSORIES & OPTIONS

- 2183464** Remote air-cooled condensing unit (one per barrel)
- 2183860** Line set 43 ft. (8 ft. flexible) (one per barrel)
- 521042** Clean-In-Place System
- 2208610** Clean-In-Place System Parts Kit (includes spigots, auger supports, and o-rings)
- Side Handle Option (-SH suffix)** All models are available with side handles which can be kept open for large dispensing.

GENERAL FEATURES

- NSF approved food grade plastic blades provide quiet operation and superior durability.
- Simplified design for quick assembly after cleaning.
- Adjust the dispense rate to meet your requirements.
- Clear door displays circulating product for merchandising appeal.
- Efficient freezing cylinder and auger design delivers a consistent uniform product with small ice crystals and a quick recovery time.
- Highly efficient auger design gently folds the entire contents of the freezing cylinder, delivering a thick, smooth, and creamy product.
- Self-closing spigot eliminates waste and ensures precise portion control.
- Pump approved for clean-in-place, reducing cleaning time and labor requirements.
- Mix containers in the refrigerated storage cabinet safely hold up to 16 gallons of mix, providing enough product during peak times and reducing the frequent refills.
- Long-wearing parts offer lower preventative maintenance costs.
- Tamper-proof controls for self-serve applications.
- Maintains constant temperature with fast evaporator defrost.

Approvals	Date

U431-12 SOFT SERVE PRESSURE FED FLOOR MACHINES

DIMENSIONS

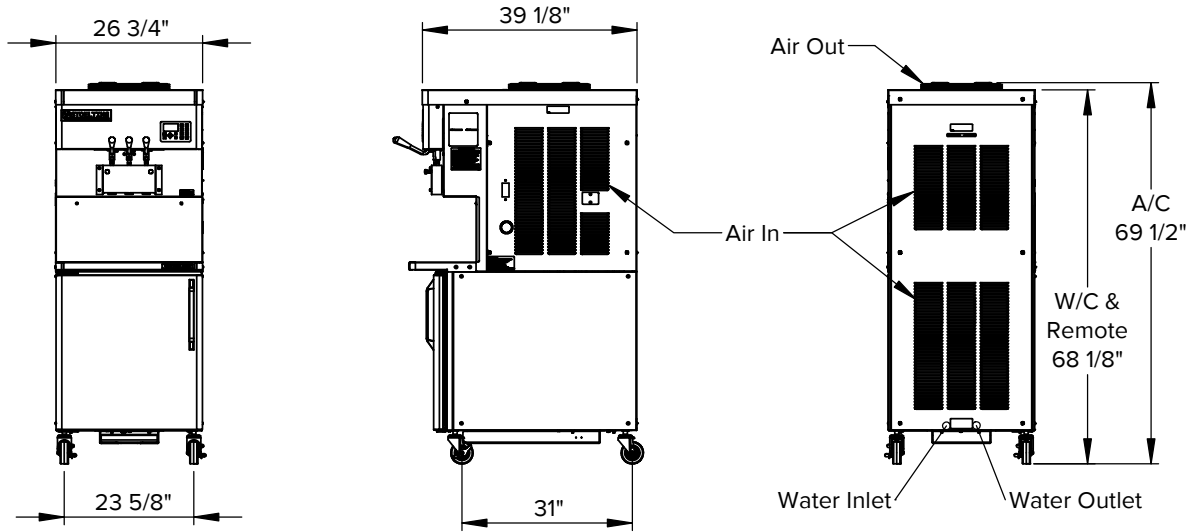

Height dimensions may vary ±1" due to casters

GENERAL SPECIFICATIONS

Freezing Cylinder				Cabinet				Drive Motor (hp)	Weight lb (kg)	Crated Weight lb (kg)
Capacity gallon (L)	Compressor			Capacity gallon (L)	Compressor					
	Btu/hr	Refrigerant	Charge (oz)		Btu/hr	Refrigerant	Charge (oz)			
Two 1.33 (5.03)	Two 19,000	R-448A	A/C: 50 W/C: 38 Remote: 224	16 (60.6)	1,300	R-134a	8	Two 2	760 (344.7)	930 (421.8)

- Indoor use only
- Maximum ambient temperature: 100°F (37.8 °C)
- Requires one dedicated electrical circuit per barrel
- Electrical plug not included. Hardwired connection required.
- Water cooled units require: 1/2" N.P.T. water and drain fittings. Maximum water pressure of 130 psi. Minimum water flow rate of 3 GPM per barrel. Ideal EWT of 50°-70°F. Minimum clearance of 6" (15.2 cm) air space on all sides.
- Air cooled units require: Minimum clearance of 6" (15.2 cm) air space on all sides and open at the top
- Remote air cooled units require: two remote condensers and two precharged line sets. Minimum clearance of 6" (15.2 cm) air space on all sides.
- Details on CAD Revit Symbols Libraries are available on stoelting.klccad.com

ITEM NUMBER SPECIFICATIONS

Model Number	Cooling	Phase	Volts	Hz	Minimum Circuit Ampacity (Amps)	Maximum Overcurrent Protection Device (Amps)	Side Handle	
U431-3812	Air	1	208-240	60	33.3	45	—	
U431-30912		3	208-240		21.8	30	—	
U431-30912-SH								✓
U431-1812	Water	1	208-240	60	33.3	45	—	
U431-1812-SH								✓
U431-10912		3	208-240		21.8	30	—	
U431-10912-SH							✓	
U431-4812	Remote Air	1	208-240	60	33.3	45	—	
U431-4812-SH								✓
U431-40912		3	208-240		21.8	30	—	
U431-40912-SH							✓	



Service Information
 800-319-9549 (U.S. Toll Free)
 920-894-2293 (Outside the U.S.)
www.stoeltingfoodservice.com
www.vollrath.com