



**STOELTING®**  
FOODSERVICE EQUIPMENT  
**Model DC-4, DC-4T**  
**OWNER'S MANUAL**

Manual No. 513629

August, 2007



## DIPPING CABINET DC-4 AND DC-4T

The dipping cabinet allows for the storage of freshly run custard for use in cones, dishes and other products. The dipping cabinet features an adjustable digital temperature controller which holds the custard at a consistent dipping temperature. The dipping cabinet has four 4.25 gallon removable square buckets.

This manual is designed to assist in the use of the DC-4 and DC-4T dipping cabinets.



Dipping Cabinet (DC-4T Shown)

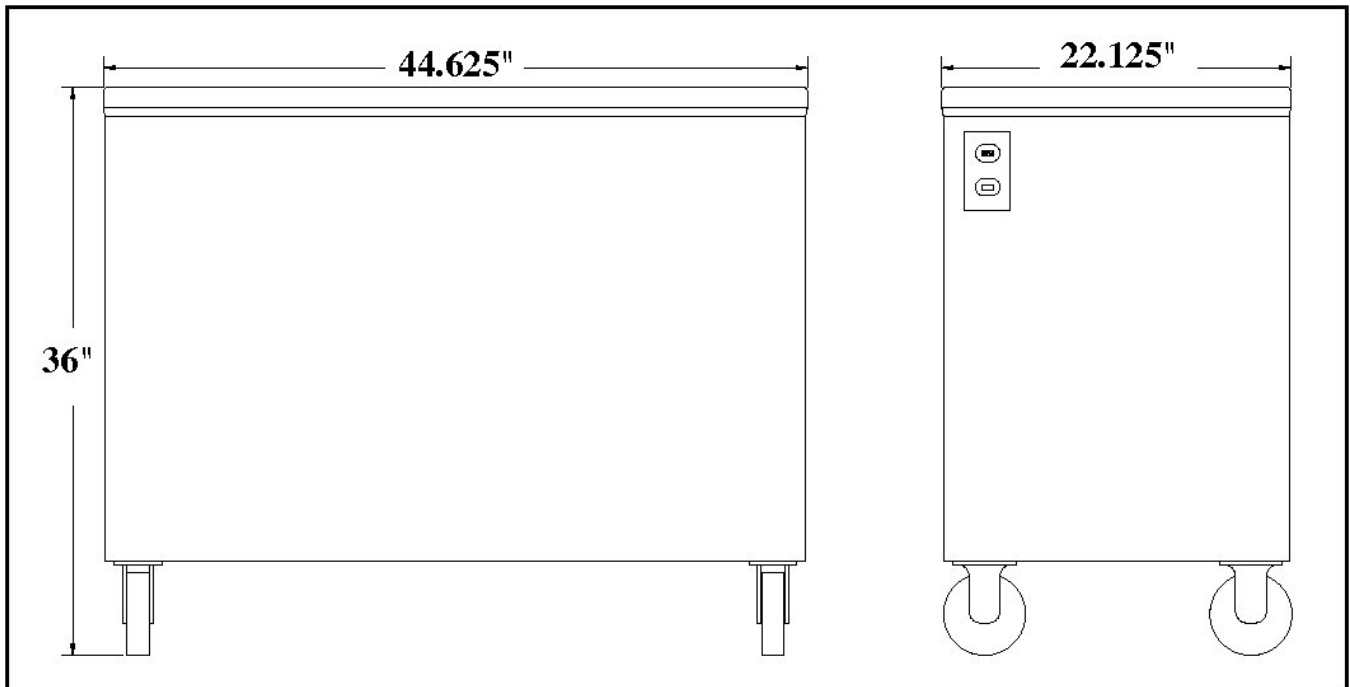

Dimensions

## CAUTION

### Electrical Hazard

Do not operate the dipping cabinet unless the receptacle has an electrical ground. Do not attempt any repairs unless the power has been disconnected.

## CLEANING THE DIPPING CABINET

The frequency of cleaning must comply with local health regulations. To clean the dipping cabinet, refer to the following steps:

1. Remove the buckets from the dipping cabinet and take them to the washing station.
2. Turn the dipping cabinet power switch OFF. This must be done daily to allow the cabinet to reach above freezing temperatures.
3. Remove the stainless steel covers and take them to the washing station.
4. Prepare detergent water by mixing 2 oz. of Palmolive detergent or equivalent in 2 gallons of 90° to 110°F water.
5. Place the buckets and covers in the detergent solution. Clean the buckets and covers with a towel or sponge.
6. Thoroughly wash the dipping cabinet exterior, bucket well, and trough with a clean towel and the detergent solution.
7. Rinse all cleaned surfaces with a clean towel and water. Dry all surfaces with a clean dry towel.

## SANITIZING THE DIPPING CABINET

Sanitizing must be done after the dipping cabinet is cleaned and before any product is added. Sanitizing the night before is not effective. However, you should always clean the dipping cabinet and parts after each use.

When sanitizing the freezer, refer to local sanitary regulations for applicable codes and recommended sanitizing products and procedures. The frequency of sanitizing must comply with local health regulations.

In general, sanitizing may be conducted as follows:

1. Prepare Stera-Sheen Green Label Sanitizer or equivalent according to manufacturer's instructions to provide a 100 parts per million strength solution. Mix sanitizer in quantities of no less than 2 gallons of 90° to 110°F water.

2. Place the cleaned buckets and covers into the sanitizer solution.
3. With a clean and sanitized towel, wipe the dipping cabinet exterior, bucket well, and trough.
4. Remove the buckets and covers from the sanitizer solution and let them air dry.
5. Place the buckets into the well and install the covers onto the dipping cabinet.
6. Turn the dipping cabinet power switch ON.

### NOTE

*Allow the dipping cabinet to operate for at least 2 hours prior to adding any custard.*

## Typical Settings for DC4 and DC4T

**Note: Please use these settings as guidelines. Each cabinet may vary and should be set up for highest efficiency, best quality, and preferred product texture. Space has been provided for inputting the final settings after set up**

### Settings for Lemon Ice Bucket

		<u>Factory Settings</u>	<u>Your Settings</u>
Press set button on thermostat once	F/C:	F	_____
Press set button again	S1	10°	_____
Press set button again	Diff 1:	2°	_____
Press set button again	Mode:	C1	_____
Press set button again	S1	0	_____
Press set button again	Diff 2	2	_____
Press set button again	Mode	C2	_____

Press the set button one more time and it will show current temperature and lock in any changes that were made.

### Settings for Custard Buckets

		<u>Factory Settings</u>	<u>Your Settings</u>
Press set button on thermostat once	F/C:	F	_____
Press set button again	S1	10°	_____
Press set button again	Diff 1:	2°	_____
Press set button again	Mode:	C1	_____
Press set button again	S1	0	_____
Press set button again	Diff 2	2	_____
Press set button again	Mode	C2	_____

Press the set button one more time and it will show current temperature and lock in any changes that were made.

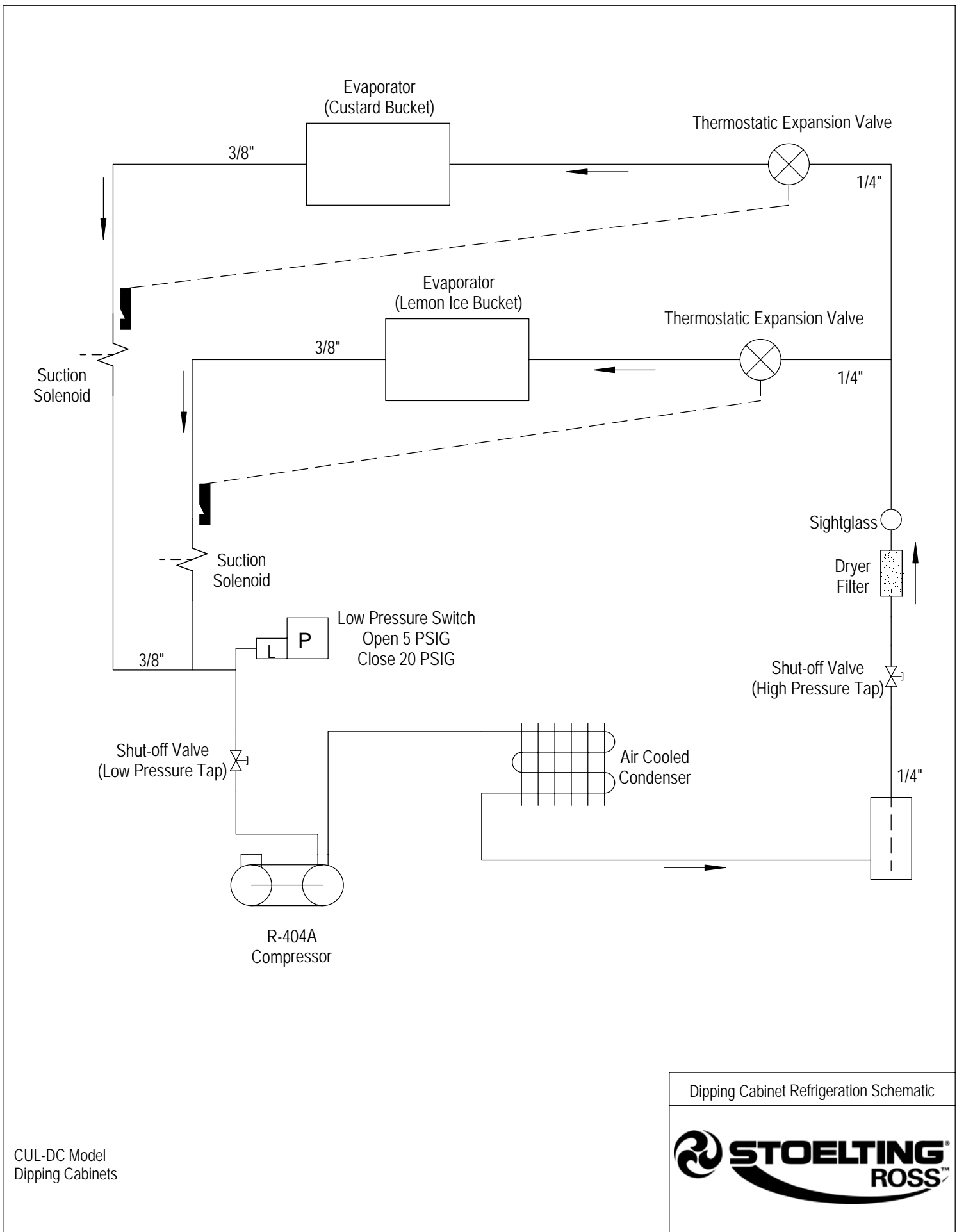

Dipping Cabinet Refrigeration Schematic

**STOELTING**  
**ROSS**

CUL-DC Model  
Dipping Cabinets

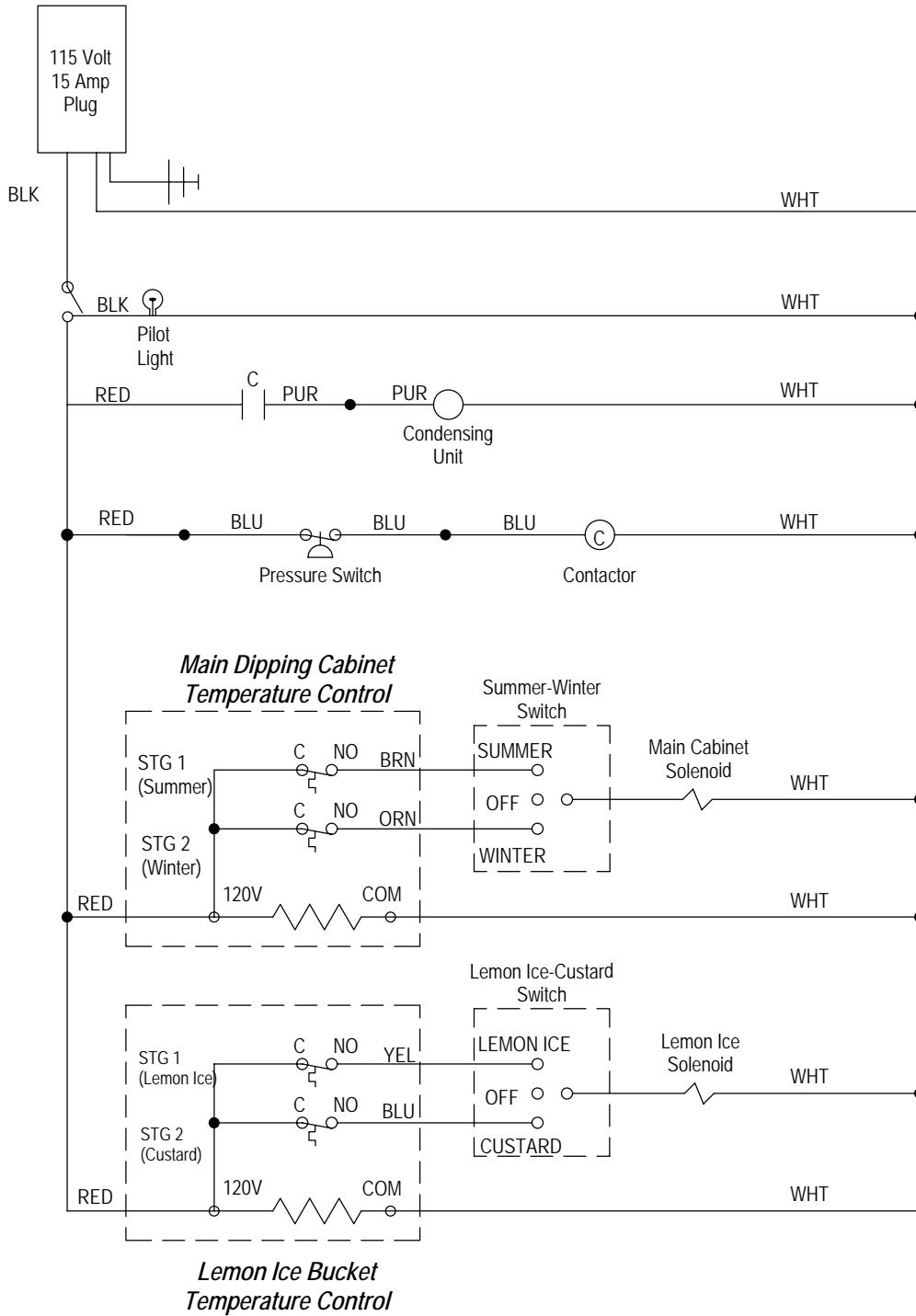

Dipping Cabinet  
CUL-DC-4  
DC4T

Electrical Schematic

