



Project:

Item Number:

Quantity:

U412 & SU412 SINGLE FLAVOR, PRESSURIZED SHAKE FREEZER WITH REFRIGERATED CABINET



DESCRIPTION

Single flavor, pressurized shake freezer with refrigerated cabinet provides greater reliability and quieter operation with Stoelting's high-efficiency evaporator and Scroll Compressor. Proprietary auger design gently folds mix and prevents product breakdown. Refrigerated mix storage cabinet has a slide-out mix shelf and a non-contact mix-pump system. Built for consistent control of all mixes.

ITEMS

- U412-38I** Air cooled, single phase
- SU412-38I** Air cooled, single phase, with Spinner
- SU412-38I** Water cooled, single phase, with Spinner

ACCESSORIES & OPTIONS

- Front Door Mounted Spinner (S Prefix)** Dispensing and mixing product is accomplished with a single front-mounted handle for fastest speed of service.

FEATURES

- NSF approved food grade plastic blades provide quiet operation and superior durability.
- Adjustable speed on the mixer.
- Simplified design for quick assembly after cleaning.
- Clear door displays circulating product for merchandising appeal.
- Highly efficient auger design gently folds the entire contents of the freezing cylinder, delivering a thick, smooth, and creamy product.
- Pump approved for clean-in-place, reducing cleaning time and labor requirements.
- Mix containers in the refrigerated storage cabinet safely hold up to 8 gallons of mix, providing enough product during peak times and reducing the frequent refills.
- Tamper-proof controls for self-serve applications.
- Reliable and quiet with the combination of Stoelting's evaporator system and the Scroll™ compressor.
- Mix pumps inject the exact amount of air into your mix, maintaining overrun to ensure maximum profitability.

 Every machine includes Stoelting's White Glove Service. One call does it all – customer service, technical service, parts or warranty information, installation, startup, sales, on-site service dispatch and much more. Available 24 hours a day, seven days a week year-round.

Continuous research leads to ongoing product improvements; therefore, these specifications are subject to change without notice and should not be used as installation specifications.

| Approvals | Date |
|-----------|------|
| | |

U412 & SU412 SINGLE FLAVOR, PRESSURIZED SHAKE FREEZER WITH REFRIGERATED CABINET

DIMENSIONS

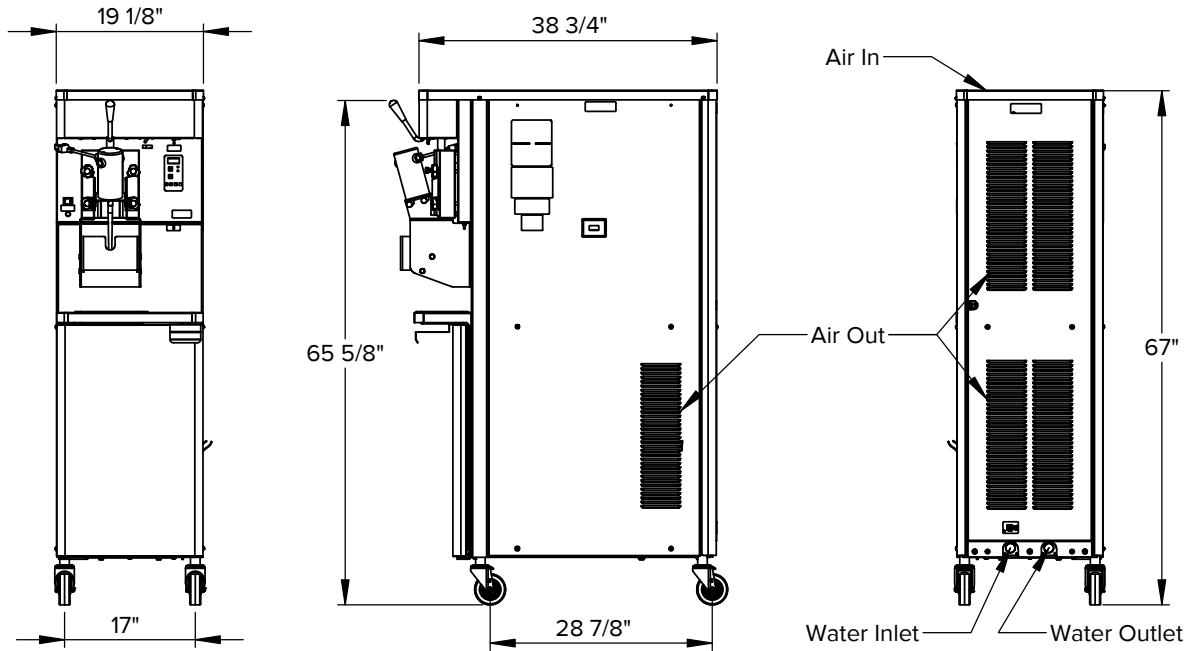

Height dimensions may vary ±1" due to casters

GENERAL SPECIFICATIONS

| Freezing Cylinder | | | | Cabinet Capacity gallon (L) | Drive Motor (hp) | Weight lb (kg) | Crated Weight lb (kg) |
|---------------------|------------|-------------|--------------------|-----------------------------|------------------|----------------|-----------------------|
| Capacity gallon (L) | Compressor | | | | | | |
| | Btu/hr | Refrigerant | Charge (oz) | | | | |
| 2.1 (7.95) | 11,000 | R-448A | A/C: 34 W/C: 26 | 8 (30.3) | 3/4 | 450 (204.1) | 550 (249.5) |

- Indoor use only.
- Maximum ambient temperature: 100°F (37.8°C).
- Requires a dedicated electrical circuit.
- Electrical plug not included. Hardwired connection required.
- Air cooled units require: 3" (7.6 cm) air space on both sides and 6" at the back.
- Water cooled units require: 1/2" N.P.T. water and drain fittings. Maximum water pressure of 130 psi. Minimum water flow rate of 3 GPM. Ideal EWT of 50°-70°F.
- Details on CAD Revit Symbols Libraries are available on stoelting.klccad.com

ITEM NUMBER SPECIFICATIONS

| Model Number | Cooling | Phase | Volts | Hz | Maximum Overcurrent Protection Device (Amps) | Minimum Circuit Ampacity (Amps) | Front Door Mounted Spinner |
|--------------|---------|-------|---------|----|--|---------------------------------|----------------------------|
| SU412-18l | Water | 1 | 208-240 | 60 | 30 | 18 | ✓ |
| SU412-38l | Air | 1 | 208-240 | 60 | 30 | 19 | ✓ |
| U412-38l | Air | 1 | 208-240 | 60 | 30 | 18 | — |



Service Information
 800-319-9549 (U.S. Toll Free)
 920-894-2293 (Outside the U.S.)
www.stoeltingfoodservice.com
www.vollrath.com