

U411-I2 SOFT SERVE PRESSURE FED SINGLE FLAVOR FLOOR MACHINE

DESCRIPTION

Single cylinder, pressure fed, soft serve machine with refrigerated mix storage cabinet. Ultra high production capacity. Offers a high dispensing rate. Ideal choice for restaurants, schools, cafeterias, drive-ins, recreational facilities, and ice-cream parlors.



Every machine includes Stoelting's White Glove Service. One call does it all – customer service, technical service, parts or warranty information, installation, startup, sales, on-site service dispatch and much more. Available 24 hours a day, seven days a week year-round.

ITEMS

- U411-38I2** Air cooled, single phase
- U411-309I2** Air cooled, three phase
- U411-18I2** Water cooled, single phase
- U411-109I2** Water cooled, three phase

ACCESSORIES & OPTIONS

- 2208100** Stainless Steel Bag Adapter

FEATURES

- NSF approved food grade plastic blades provide quiet operation and superior durability.
- Simplified design for quick assembly after cleaning.
- Adjust the dispense rate to meet your requirements.
- Clear door displays circulating product for merchandising appeal.
- Efficient freezing cylinder and auger design delivers a consistent uniform product with small ice crystals and a quick recovery time.
- Highly efficient auger design gently folds the entire contents of the freezing cylinder, delivering a thick, smooth, and creamy product.
- Self-closing spigot eliminates waste and ensures precise portion control.
- Pump approved for clean-in-place, reducing cleaning time and labor requirements.
- Compact floor unit design saves valuable floor space.
- Mix containers in the refrigerated storage cabinet safely hold up to 8 gallons of mix, providing enough product during peak times and reducing the frequent refills.
- Long-wearing parts offer lower preventative maintenance costs.
- Tamper-proof controls for self-serve applications.
- Maintains constant temperature with fast evaporator defrost.

IntelliTec2™ Control

- Programmable and configurable through multi-line graphics display.
- Upload firmware and download statistics through a USB connection.
- Performance and error logs provide data to maximize profitability.
- Senses product consistency or temperature to customize for a wide variety of mixes.
- Standby and sleep modes conserve energy and automatically defrost product, maintaining small ice crystals and delivering a superior mouthfeel.

Continuous research leads to ongoing product improvements; therefore, these specifications are subject to change without notice and should not be used as installation specifications.

Approvals	Date

U411-I2 SOFT SERVE PRESSURE FED SINGLE FLAVOR FLOOR MACHINE

DIMENSIONS

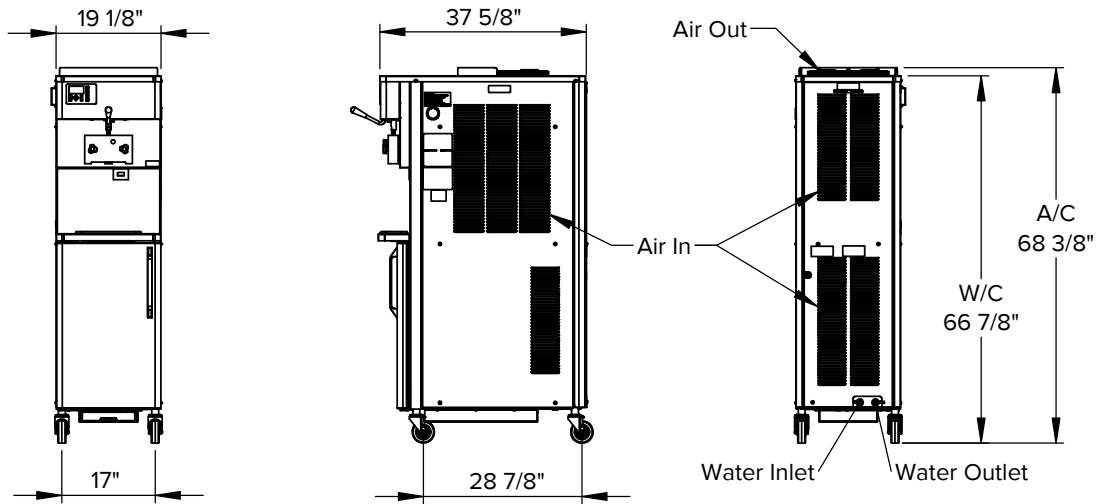

Height dimensions may vary ±1" due to casters

GENERAL SPECIFICATIONS

Freezing Cylinder				Cabinet				Drive Motor (hp)	Weight lb (kg)	Crated Weight lb (kg)
Capacity gallon (L)	Compressor			Capacity gallon (L)	Compressor					
	Btu/hr	Refrigerant	Charge (oz)		Btu/hr	Refrigerant	Charge (oz)			
1.33 (5.03)	15,000	R-448A	A/C: 40 W/C: 30	8 (30.3)	1,300	R-134a	8	2	450 (204.1)	650 (294.8)

- Indoor use only.
- Maximum ambient temperature: 100°F (37.8°C).
- Requires a dedicated electrical circuit.
- Power cord provided.
- All units require: 3" (7.6 cm) air space at the back and sides.
- Water cooled units require: 1/2" N.P.T. water and drain fittings. Maximum water pressure of 130 psi. Minimum water flow rate of 3 GPM. Ideal EWT of 50°-70°F.
- Details on CAD Revit Symbols Libraries are available on stoelting.klccad.com

ITEM NUMBER SPECIFICATIONS

Model Number	Cooling	Phase	Volts	Hz	Running Amps	Cord with Plug (Included)
U411-38I2	Air	1	208-240	60	18	NEMA L6-30P
U411-309I2		3			16	NEMA L15-30P
U411-18I2	Water	1	208-240	60	17	NEMA L6-30P
U411-109I2		3			15	NEMA L15-30P



Service Information
 800-319-9549 (U.S. Toll Free)
 920-894-2293 (Outside the U.S.)
www.stoeltingfoodservice.com
www.vollrath.com