



Project:

Item Number:

Quantity:

0431-12F SOFT SERVE PRESSURE-FED TWIN TWIST FLOOR MACHINES



DESCRIPTION

Slim, twin twist, floor model soft serve/frozen yogurt pressure freezer with mix storage refrigerated cabinet. Maintains high production capacity in high temperature conditions. Ideal choice for locations where space is an issue.

ITEMS

- 0431-3812F** Air cooled, single phase
- 0431-30912F** Air cooled, three phase
- 0431-1812F** Water cooled, single phase
- 0431-10912F** Water cooled, three phase

ACCESSORIES & OPTIONS

- 2208100** Stainless Steel Bag Adapter

FEATURES

- NSF approved food grade plastic blades provide quiet operation and superior durability.
- Simplified design for quick assembly after cleaning.
- Adjust the dispense rate to meet your requirements.
- Clear door displays circulating product for merchandising appeal.
- Efficient freezing cylinder and auger design delivers a consistent uniform product with small ice crystals and a quick recovery time.
- Highly efficient auger design gently folds the entire contents of the freezing cylinder, delivering a thick, smooth, and creamy product.
- Self-closing spigot eliminates waste and ensures precise portion control.
- Pump approved for clean-in-place, reducing cleaning time and labor requirements.
- Compact floor unit design saves valuable floor space.
- Mix containers in the refrigerated storage cabinet safely hold up to 11 gallons of mix, providing enough product during peak times and reducing the frequent refills.
- Long-wearing parts offer lower preventative maintenance costs.

IntelliTec2™ Control

- Programmable and configurable through multi-line graphics display.
- Upload firmware and download statistics through a USB connection.
- Performance and error logs provide data to maximize profitability.
- Senses product consistency or temperature to customize for a wide variety of mixes.
- Standby and sleep modes conserve energy and automatically defrost product, maintaining small ice crystals and delivering a superior mouthfeel.

 Every machine includes Stoelting's White Glove Service. One call does it all – customer service, technical service, parts or warranty information, installation, startup, sales, on-site service dispatch and much more. Available 24 hours a day, seven days a week year-round.

Continuous research leads to ongoing product improvements; therefore, these specifications are subject to change without notice and should not be used as installation specifications.

Approvals	Date

0431-I2F SOFT SERVE PRESSURE-FED TWIN TWIST FLOOR MACHINES

DIMENSIONS

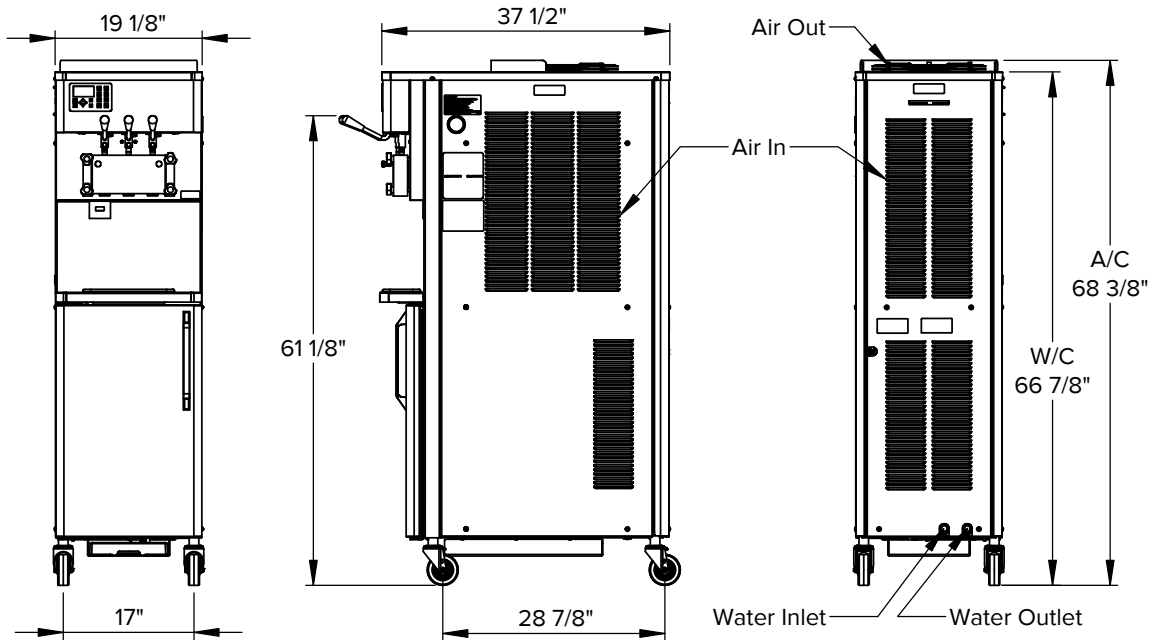

Height dimensions may vary ±1" due to casters

GENERAL SPECIFICATIONS

Model	Freezing Cylinder				Cabinet				Drive Motor (hp)	Weight lb (kg)	Crated Weight lb (kg)
	Capacity gallon (L)	Compressor			Capacity gallon (L)	Compressor					
		Btu/hr	Refrigerant	Charge (oz)		Btu/hr	Refrigerant	Charge (oz)			
0431-I2F	Two 1 (3.8)	15,000	R-448A	A/C: 38 W/C: 28	Two 5.5 (20.8)	1,300	R-134A	8	Two 2	500 (226.8)	770 (349.3)

- Indoor use only.
- Maximum ambient temperature: 100°F (37.8°C).
- Requires one dedicated electrical circuit per barrel.
- Power cord provided.
- Air cooled units require: 3" (7.6 cm) air space at the back and sides.
- Water cooled units require: 1/2" N.P.T. water and drain fittings. Maximum water pressure of 130 psi. Minimum water flow rate of 3 GPM per barrel. Ideal EWT of 50°-70°F.
- Details on CAD Revit Symbols Libraries are available on stoelting.klclcad.com

ITEM NUMBER SPECIFICATIONS

Model Number	Cooling	Phase	Volts	Hz	Running Amps	Cord with Plug (Included)
0431-38I2F	Air	1	208-240	60	23	NEMA L6-30P
0431-309I2F		3			19	NEMA L15-30P
0431-18I2F	Water	1	208-240	60	22	NEMA L6-30P
0431-109I2F		3			18	NEMA L15-30P



Service Information
 800-319-9549 (U.S. Toll Free)
 920-894-2293 (Outside the U.S.)
www.stoeltingfoodservice.com
www.vollrath.com