

MIWE gusto snack with TC control system
Unit version 3.0

LEGAL NOTICE

This document is to be treated as confidential. It is intended solely for persons who work with the unit. This document may not be provided to third parties without the written consent of the manufacturer.



LEGAL NOTICE

The specifications, text, drawings, images and all other information and graphics contained in this document are protected by copyright and industrial property rights.

Persons making unauthorised commercial use of this document or its content shall be open to prosecution.

This document may not be reproduced in any way or form, in whole or in part, nor may its content be used and/or communicated without the written consent of the manufacturer. Parties breaching this provision shall be liable for damages. All rights reserved.

Copyright 2014 by
MIWE Michael Wenz GmbH
P.O. Box 20, D-97448 Arnstein
Phone +49-(0)9363-680
Fax +49-(0)9363-688400
e-mail contact@miwe.de
www.miwe.com

1.	IMPORTANT INFORMATION	7
1.1.	Intended use	7
1.2.	Foreseeable misuse	8
1.3.	Area of use	8
1.4.	Certification	9
1.4.1.	EC declaration of conformity	9
1.4.2.	CE mark	9
1.5.	About this documentation	9
1.6.	Explanation of symbols	9
1.6.1.	Warnings	9
1.6.2.	Special hazards	10
1.6.3.	Notes	10
1.7.	Limitation of liability	11
1.8.	MIWE service	11
2.	SAFETY	12
2.1.	Responsibility of the owner-operator	12
2.2.	Accident prevention and first aid	13
2.3.	Personnel	13
2.4.	Protective clothing	14
2.5.	Storage	15
2.6.	Signs and labels	15
3.	UNIT DESCRIPTION	18
3.1.	Scope of delivery	18
3.1.1.	Baking trays	18
3.2.	Design	19
3.2.1.	Door models	19
3.2.2.	Single circuit system	20
3.2.3.	DUO model	23
3.2.4.	Vapour hood with steam condenser	24

3.3.	Functioning principle	25
3.3.1.	Oven	25
3.3.2.	Vapour hood with steam condenser	26
3.4.	Safety devices	27
3.4.1.	Multiple glazing, oven door	27
3.4.2.	Safety temperature limiter	27
3.4.3.	Power connection	27
3.4.4.	Emergency release	28
3.5.	Description of work areas	28
3.5.1.	Work area for operating personnel	29
3.5.2.	Work area for maintenance and cleaning personnel	29
4.	INSTALLATION BY MIWE SERVICE	30

5.	INSTALLATION BY OWNER-OPERATOR	31
-----------	---------------------------------------	-----------

5.1.	Safety information	31
5.2.	Installation preparations	32
5.2.1.	Removing protective film	32
5.3.	Positioning the components	33
5.4.	Connecting the components	34
5.4.1.	Two ovens, one above the other	34
5.4.2.	Oven with base units	36
5.4.3.	Vapour hood with steam condenser on oven	37
5.5.	Electrical system	38
5.5.1.	Connecting the oven	38
5.5.2.	Connecting the vapour hood with steam condenser	39
5.6.	Water supply	40
5.6.1.	Connecting the water supply line	41
5.7.	Water drain	42
5.7.1.	Connecting the water drainage hose to the oven	42
5.7.2.	Connecting the condensate hoses	43
5.7.3.	Fitting the siphon (optional)	44
5.7.4.	Draining water and condensate	45

5.8.	Steam	48
5.8.1.	Connecting the steam outlet	48
5.9.	Connecting the data line between two ovens	49
6.	COMMISSIONING BY MIWE SERVICE	50

6.1.	Commissioning	50
6.1.1.	Training	50
6.1.2.	Handover to the owner-operator with a handover report	50
7.	COMMISSIONING BY THE OWNER-OPERATOR	51

7.1.	Safety information	51
7.2.	Commissioning	51
7.2.1.	Checking the mechanical and electrical devices	51
7.2.2.	Trial operation	51
7.2.3.	Training	51
7.3.	MIWE cleaning control cleaning program	52
7.3.1.	Safety information	52
7.3.2.	Filling the cleaner tank	52
8.	OPERATION	53

8.1.	Safety instructions	53
8.2.	Operating modes	54
8.3.	User selection	55
8.3.1.	Changing users	55
8.4.	MIWE TC controls (Touch Control)	56
8.4.1.	About the operating unit	56
8.5.	Ready for operation	56
8.6.	Switching the controls ON / OFF	57
8.7.	OFF mode	57

8.8.	AUTOMATIC MODE	58
8.8.1.	Selecting a baking program	58
8.8.2.	Ready to bake	58
8.8.3.	OPEN / CLOSE baking chamber door – model with side-hinged door	59
8.8.4.	OPEN / CLOSE baking chamber door – model with bottom-hinged door	60
8.8.5.	Loading the oven	61
8.8.6.	Starting the baking process	62
8.8.7.	Cancelling the baking process	62
8.8.8.	Unloading the oven	62
8.9.	Managing baking programs	63
8.9.1.	Creating and changing baking programs	64
8.9.2.	Copying and pasting baking programs	67
8.9.3.	Deleting baking programs	68
8.10.	Cleaning programs	69
9.	FAULTS	70

9.1.	Safety information	70
9.2.	What to do in the event of a fault	72
9.3.	Electrical and mechanical faults	72
9.3.1.	Actuating the safety temperature limiter	76
9.3.2.	Opening the baking chamber with the emergency release function	76

10.	CLEANING AND CARE	77
------------	--------------------------	-----------

10.1.	Safety information	77
10.2.	Cleaning schedule	78
10.3.	Cleaning	78
10.3.1.	Casing	79
10.3.2.	Operating unit	79
10.3.3.	Baking chamber	80
10.3.4.	Glass panel	80
10.3.5.	Door seal	84
10.3.6.	Tray supports	85
10.3.7.	Baking trays	86
10.3.8.	Container for waste water	87
10.3.9.	Vents	88
10.3.10.	Collection channel for baking residue	89

10.4.	Cleaning programs for the baking chamber	90
10.4.1.	Safety information	90
10.4.2.	Checking the spray nozzle function	91
10.4.3.	Checking the door seal	91
10.4.4.	Check at the end of the cleaning program	92
10.5.	MIWE cleaning control cleaning program	93
10.5.1.	Safety information	93
10.5.2.	Filling up the cleaning agent	93
10.5.3.	Running a cleaning program	96
10.6.	MIWE easy clean cleaning program	98
10.6.1.	Safety information	98
10.6.2.	Preparing cleaning solution and equipment	99
10.6.3.	Running a cleaning program	99

11. INSPECTION AND MAINTENANCE **101**

11.1.	Safety information	101
11.2.	Maintenance schedule	103
11.2.1.	Maintenance by the owner-operator	103
11.2.2.	Maintenance/service by MIWE service	104
11.3.	Maintenance instructions	104
11.3.1.	Cleaning the siphon	104
11.3.2.	Rinsing the water drainage hoses	106
11.3.3.	Changing the door seal	107
11.3.4.	Cleaning the vapour hood with steam condenser	109
11.3.5.	Cleaning the filter in the water system connection piece	110
11.3.6.	Changing magnets on the door frame	112
11.3.7.	Adjusting the baking chamber door pin and catch	116
11.3.8.	Changing the snap fit in the cover panel	120
11.3.9.	Cleaning the steam outlet	122
11.4.	Start-up after maintenance	122

12.	TECHNICAL DATA	123
12.1.	Technical data – product versions	123
12.2.	Rating plate	123
13.	WEAR AND SPARE PARTS LIST	124
14.	SHUT-DOWN AND DISPOSAL	128
14.1.	Safety information	128
14.2.	Environmental protection	128
15.	EC DECLARATION OF CONFORMITY	129

1. Important information

1.1. Intended use

The MIWE gusto snack is an electric oven for commercial use.

It is suitable for baking, cooking, roasting and heating food in accordance with current food regulations.

The MIWE gusto snack is a tabletop unit.

The main modules are as follows:

Oven

The MIWE gusto snack can operate

- as a convection oven
- with radiant heat (top heat)
- in mixed mode (convection and radiant heat)
- as a steamer

It can consist of up to two baking chambers, one above the other. The baking chambers are operated separately.

All products must be baked on baking trays/the heat storage plates recommended by MIWE.

Vapour hood with steam condenser

- Any smells and vapour produced are collected and extracted.
- Steam produced is condensed. The dry waste air and the condensate are discharged separately.

Base frame

- Mechanical base with adjustable feet, available in various heights.

Intermediate compartment

- Mechanical base

Mechanical and electrical safety devices

- For safe operation

Process controls with operating unit

**WARNING!**

The oven is suitable for products with a natural alcohol content of up to a max. of 1 % by weight.

The unit may not be used for products containing an excessive amount of volatile compounds (such as are formed when ingredients with a high alcohol content are added) as these can produce high levels of inflammable vapours and therefore pose a significant risk.

**SERVICE INFORMATION**

The specifications for commissioning, start-up, operation, maintenance and repair must be complied with.

1.2. Foreseeable misuse

The oven may only be used for the purpose described here.

All other uses are incorrect and are strictly prohibited. Incorrect uses include:

- Tampering with safety devices
- Baking, heating or drying other substances or organisms
- Use in the home / domestic-scale kitchens
- The unauthorised connection of other units to the MIWE oven
- Connection to an unsuitable power supply

**LEGAL NOTICE**

The manufacturer shall not be liable for damage which occurs as a result of incorrect use.

1.3. Area of use

Enclosed areas on commercial premises, e.g.:

- Restaurants
- Canteens
- Hospitals
- Bakeries
- Butcher's shops
- Snack bars
- Sales areas closed off to public access

1.4. Certification

1.4.1. EC declaration of conformity

MIWE issues a manufacturer EC declaration of conformity pursuant to the EC Machinery Directive 2006/42/EC, Annex IIa and EN ISO/IEC 17050-1. The declaration of conformity is an integral part of the overall documentation.

1.4.2. CE mark



The manufacturer has awarded the CE mark on the basis of the declaration of conformity. The information on intended use and misuse and the safety information in this documentation is based on a risk assessment in accordance with DIN EN ISO 12100.

1.5. About this documentation

It is important that you observe all safety information and handling instructions to ensure safety on the job. The applicable local accident prevention and general safety regulations for the area of use must also be observed.

Please read the documentation carefully before beginning any work. It is an integral part of the product and must be accessible to staff at all times. If passing on the unit to third parties, also provide them with the documentation. The figures/illustrations contained in the documentation are provided for explanatory purposes only and may in the interests of clarity not necessarily be to scale. They may vary slightly from the actual version supplied.

1.6. Explanation of symbols

1.6.1. Warnings

Warnings are marked in this documentation by symbols.

The warnings are introduced by signal words which reflect the level of potential danger. You must observe the warnings and act with all due care in order to avoid accidents, injury and damage.



DANGER!

Indicates serious hazards which could lead to death or serious injury if not avoided. This symbol is only used for serious dangers.



WARNING!

Indicates moderate risk. Disregarding the safety instructions can lead to serious injury or death. This symbol is not used for risk of mere damage to property.



CAUTION!

Indicates dangers which pose only a minor risk of physical injury. This symbol is only used for risk to property.

1.6.2. Special hazards

The following symbols are used in conjunction with the safety information to indicate special hazards:



RISK OF ELECTROCUTION!

Indicates safety information regarding electric current or voltage. Failure to attend to this information can lead to serious injury or death. Work may only be carried out by specially qualified personnel. National and regional regulations in this area must be adhered to.



HEAVY LOADS CAN CAUSE INJURY!

Indicates safety instructions for handling heavy loads. Failure to attend to this information can lead to serious injury or death.



HOT SURFACES CAN CAUSE INJURY!

Indicates safety information relating to hot surfaces. Failure to attend to this information can lead to serious injury.



CRUSH HAZARD!

Indicates safety instructions for handling moving components. Failure to attend to this information can lead to serious injury or death.



RISK OF INJURY FROM HOT STEAM!

Indicates safety information on the risk posed by escaping hot steam. Failure to attend to this information can lead to serious injury.

1.6.3. Notes



NOTE!

Highlights useful tips, suggestions and information for ensuring efficient and smooth operation.



LEGAL NOTICE

Indicates information on statutory guidelines and standards and legally binding agreements between manufacturer and owner-operator.



SERVICE INFORMATION

Indicates information on cleaning, care, maintenance, lubrication and servicing.



PROCEDURE

Sets out procedures to be followed by operating and service personnel.

1.7. Limitation of liability

All the information, notes and instructions contained in the documentation have been prepared in accordance with the applicable standards and regulations and the state of the art and on the basis of our extensive knowledge and experience. The manufacturer can accept no liability for loss arising from:

- Failure to follow this instruction handbook
- Incorrect use
- The use of untrained personnel
- Unauthorised modifications
- Technical modifications
- The use of unauthorised spare parts.

The actual scope of delivery may vary from that described and depicted in this handbook if a special version is delivered or additional options are ordered or if the latest technical modifications have been incorporated. The obligations agreed in the delivery contract, the General Terms and Conditions of Business and the Terms and Conditions of Delivery of the manufacturer and the statutory regulations valid at the time of the conclusion of the contract apply. We reserve the right to make technical changes in the interests of further development and the improvement of performance characteristics.

1.8. MIWE service

MIWE service provides a MIWE helpline to deal with all questions relating to MIWE products. MIWE service provides advice and support in the following areas:

1. Inspection
2. Maintenance
3. Individual service agreements covering:
 - Maintenance
 - Extended warranty
 - Repair
 - Modernisation
 - Overhaul
 - Commissioning and start-up
4. MIWE spare parts

For further information on MIWE service, details of the individual services and the competent contact persons, simply contact us by telephone, fax or e-mail or check on the Internet.

Our staff are always interested in hearing any new information you gain from using the unit which could help us improve our products.

2. Safety

This section covers all essential safety aspects so as to ensure the best possible protection for personnel and safe and smooth operation. Failure to adhere to the instructions and safety information in the instruction handbook can result in significant danger to personnel and damage to the product.

2.1. Responsibility of the owner-operator

Owner-operator

The person who operates the unit themselves for commercial or business purposes or makes it available to a third party for use or application and bears the legal product responsibility for the protection of users or third parties during operation.



NOTE!

The product is for use in the commercial sector. The owner-operator is therefore bound by statutory duties regarding health and safety at work. In addition to the safety information contained in this document, the applicable safety and accident prevention regulations and environmental standards for the unit's area of application must also be observed.

The owner-operator must:

- familiarise themselves with the applicable industrial health and safety regulations and conduct a risk assessment to establish any hazards resulting from the specific working conditions at the place of installation. The owner-operator must cover these hazards and regulations in operating instructions.
- throughout the product's entire useful life, keep checking whether the operating instructions drawn up still comply with the current rules and regulations. If they do not, they must be adapted accordingly.
- clearly define and regulate responsibility for operation, maintenance and cleaning.
- make sure that all employees handling the product have read and understood this document.
- provide personnel with regular training and inform them about the hazards.
- make sure that the unit is kept in perfect technical condition.
- make sure that the maintenance intervals are adhered to.
- check all safety devices regularly to make sure that they are complete and in good working order.
- always ensure that all housing elements and components are properly fitted before the unit is switched on.



SPECIAL DUTIES

The owner-operator must appoint a safety officer to monitor the safety devices and adherence to the safety measures.

2.2. Accident prevention and first aid

The owner-operator shall ensure safe operation and rapid help in emergency situations by putting suitable measures in place. The owner-operator shall:

- provide protective clothing for the operating and maintenance personnel.
- ensure the work area is properly lit for all work.
- prevent unauthorised access to the work area during operation by putting in place suitable protection and barriers.
- mark hazards and hazardous areas with warning signs or sounds; put in place barriers, covering for edges etc.
- ensure all safety and warning signs on the product are kept in a legible condition.
- display an evacuation plan in the unit and operating area and keep all emergency exits and escape routes clear.
- Provide fully functional and easily accessible fire extinguishers, first aid boxes, eye wash facilities and emergency telephones.

2.3. Personnel



WARNING: DANGER FOR UNAUTHORISED PERSONS!

Unauthorised persons who do not meet the requirements are not familiar with the hazards in the work area.

- Keep unauthorised persons away from the work area.
- If in doubt, speak to the persons concerned and send them out of the work area.
- Stop work until all unauthorised persons have left the work area.

Qualified personnel

Qualified personnel are able to perform the tasks assigned to them and to recognise potential hazards on the basis of their professional training, knowledge and experience and their knowledge of the relevant laws and regulations.

Trained personnel

A trained person has been trained in the procedures and technology of the unit by the manufacturer and has been informed of potential hazards resulting from incorrect handling.

Instructed personnel

Instructed personnel have been instructed by the owner-operator about the tasks they are to perform and have been informed about the potential hazards of incorrect operation.

Authorised personnel

Persons are authorized as personnel only if they can be expected to perform their work reliably. Persons whose reactions are affected by, for example, drugs, alcohol or medication are not authorized. Age- and occupation-specific regulations in force at the place of use must be observed when selecting personnel.

2.4. Protective clothing

Protective clothing must be worn for work to minimize health risks.



PROTECTIVE CLOTHING

- To protect from burns from hot surfaces and vapour. Protective clothing must have long sleeves and long legs.



PROTECTIVE GLOVES

- To protect the hands from burns from hot surfaces and vapours and from rubbing, grazing, jabbing or deeper wounds.

Special protective clothing for certain work

Additional protective clothing is required when carrying out some jobs. This is highlighted in the relevant sections of this handbook.



SAFETY GOGGLES

- To protect the eyes from splashes and hot vapours.



SAFETY SHOES

- To protect the feet from heavy falling objects.



HEARING PROTECTION

- To prevent hearing damage from noise emissions.



LIGHTWEIGHT RESPIRATORY EQUIPMENT

- To protect from harmful dusts and vapours.



CHEMICAL-RESISTANT PROTECTIVE GLOVES

- To protect the hands from aggressive substances. Check gloves for leaks before use. Clean the gloves before taking them off. Store them in a well-ventilated place.

2.5. Storage

Store the product in the following conditions:

- Do not store outdoors.
- Store in a dry and dust-free place.
- Do not expose to aggressive substances.
- Keep out of sunlight.
- Avoid mechanical shocks.
- Storage temperature: +3°C to +50°C.
- Relative humidity: max. 60%.
- If the unit is in storage for longer than 3 months, the general condition of all the parts must be checked regularly.

2.6. Signs and labels



WARNING: ILLEGIBLE SYMBOLS CAN RESULT IN INJURY!

Signs and labels indicate potential hazards and special technical functions.

Stickers and signs can over time become dirty or otherwise illegible.

- Ensure all safety signs, warning signs and operating instructions are kept in a legible condition.
- Replace damaged signs or stickers immediately.

Front



HOT SURFACE

Hot surfaces, such as hot unit components and hot fluids, are not always recognisable as such. Do not touch them unless you are wearing protective gloves.



HOT STEAM!

Escaping hot steam can scald. In areas marked by this sign, always be careful and wear suitable personal protective equipment (protective clothing, protective gloves, safety goggles).

Back**VOLTAGE**

Indicates areas in which only qualified electricians may work.

**OBSERVE THE INSTRUCTION HANDBOOK**

Only use the marked item after having read the instruction handbook.

**SOCKET LABELLING**

Indicates the power rating of the socket.

**EQUIPOTENTIAL BONDING**

Indicates the position of the bolt for connecting the equipotential bonding conductor.

**TEST STICKER**

Shows the date on which the electrical system of the unit was tested.

Inside of door**LIGHTING LABELLING**

Indicates the power rating of the lighting.

SK-II steam condenser top**VOLTAGE**

Indicates areas in which only qualified electricians may work.

**EARTH REQUIRED**

Indicates devices and components requiring an earth.

Inside of cover panel

The MIWE gusto can be delivered with the MIWE cleaning control cleaning program.
The unit has the following stickers in line with this option.

Model with MIWE cleaning control**NOT DRINKING WATER**

Do not fill with drinking water.

Only fill the tank with the cleaning agent for MIWE cleaning control cleaning program.

or

Model without MIWE cleaning control**DRINKING WATER**

Only fill the tank with drinking water.

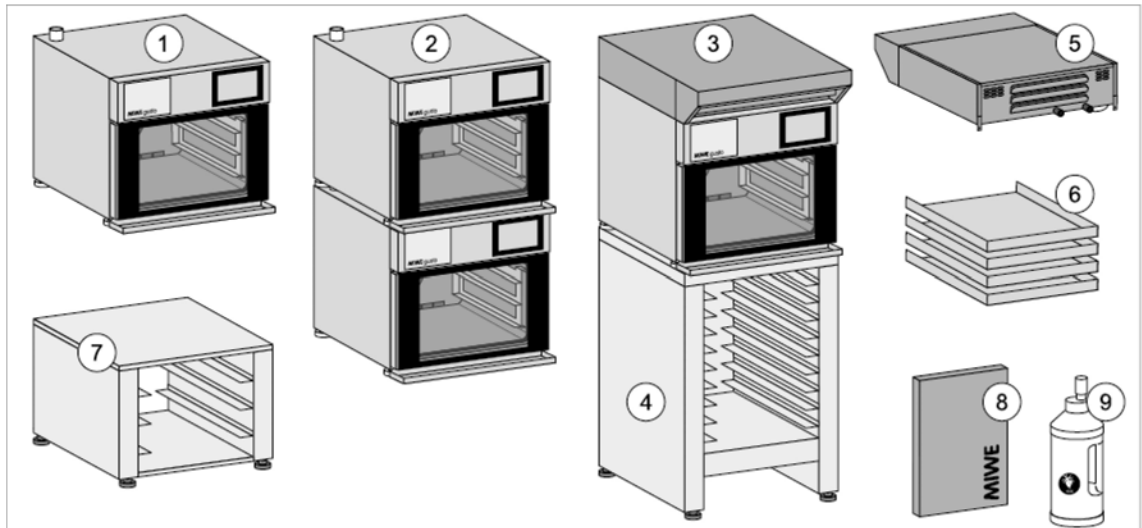
3. Unit description

3.1. Scope of delivery



NOTE!

The scope of delivery depends on the order.



- | | |
|--|---------------------------------------|
| ① Single-circuit system | ⑥ Baking trays (optional) |
| ② DUO model | ⑦ Intermediate compartment (optional) |
| ③ Baking station with vapour hood, oven and base frame | ⑧ Documentation |
| ④ Base frame with adjustable feet (optional) | ⑨ Cleaning agent (optional) |
| ⑤ Vapour hood with steam condenser (optional) | |

3.1.1. Baking trays

You will have to observe general instructions before baking for the first time.

Further information can be found in the 'Cleaning and care' section under 'Cleaning – Baking trays'.

3.2. Design



NOTE!

The detailed technical data is sent to the owner-operator together with the order confirmation.

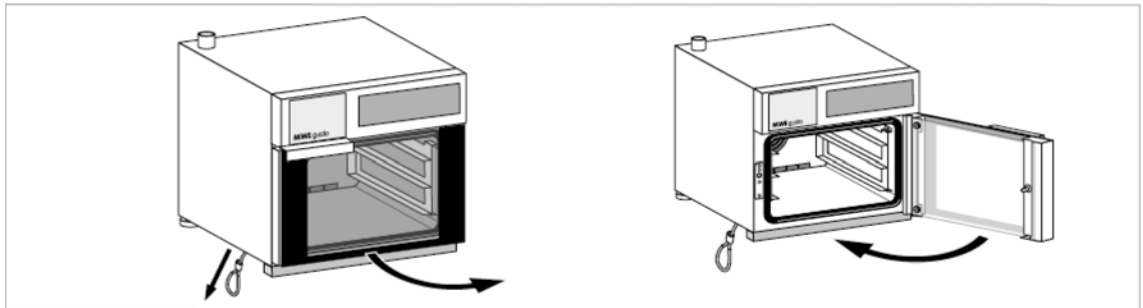
3.2.1. Door models

The MIWE gusto snack can be ordered with two different types of door.

- Side-hinged door
- Bottom-hinged door

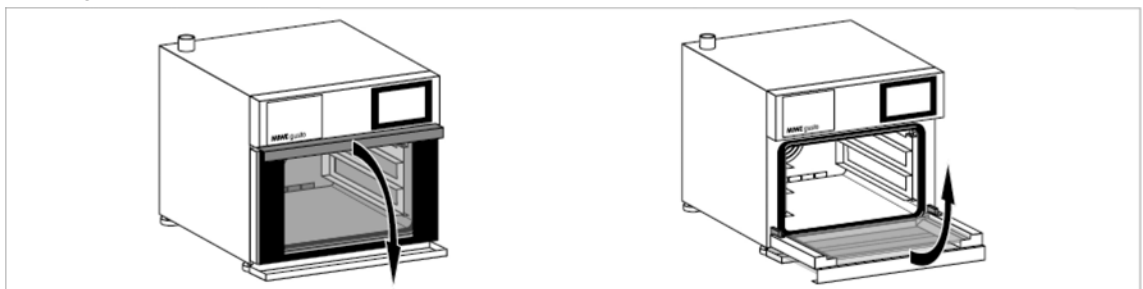
Model with side-hinged door

- Hinged on right (see figure)
- Hinged on left



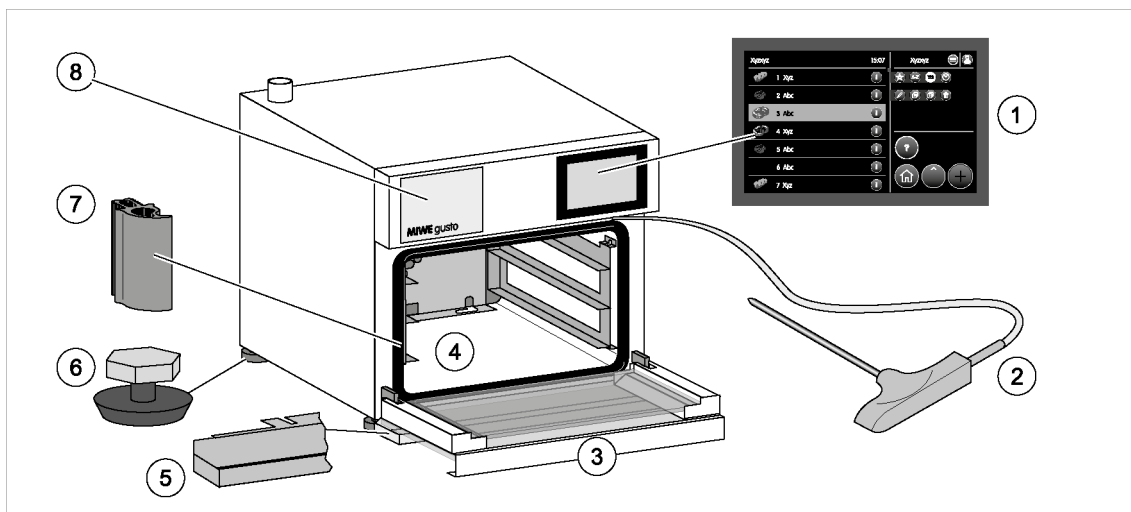
Model with bottom-hinged door

- Hinged at bottom



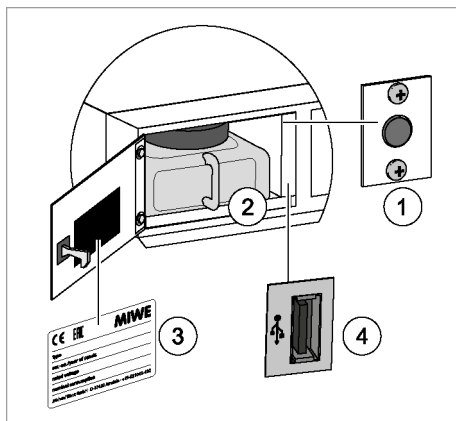
3.2.2. Single circuit system

Front section



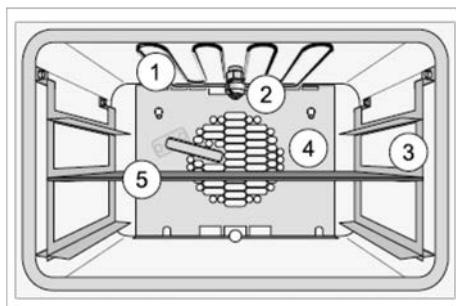
- ① Operating unit
- ② Core temperature sensor
- ③ Baking chamber door with double glazing – for further information, please see 'Door models'
- ④ Baking chamber – for further information, please see 'Baking chamber'
- ⑤ Collection channel, detachable
- ⑥ Adjustable feet
- ⑦ Door seal
- ⑧ Cover panel – for further information, please see 'Front section – cover panel'

Front section – cover panel

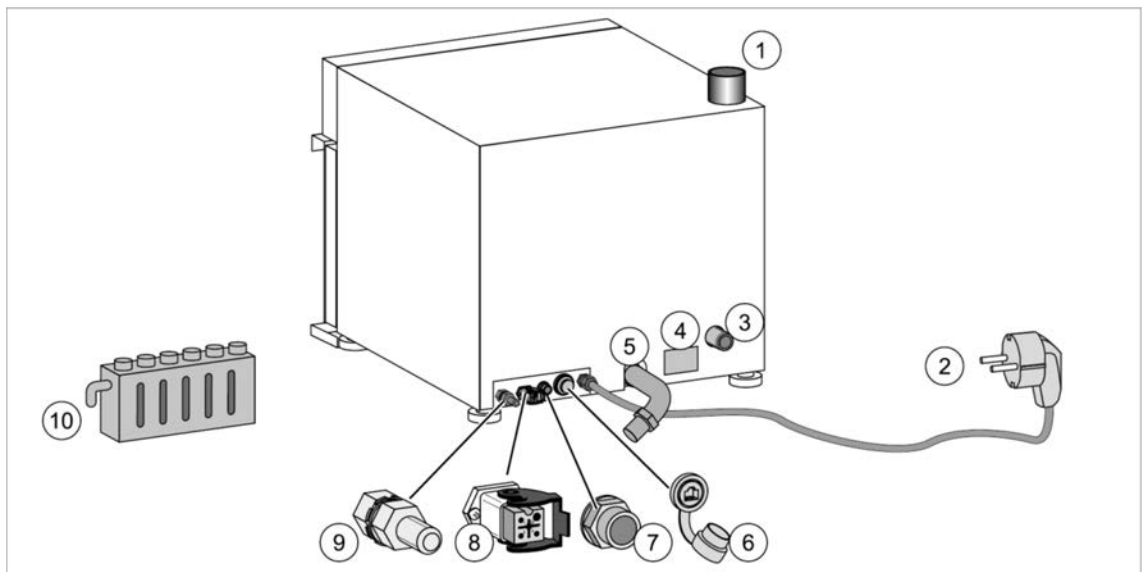


- ① Safety temperature limiter
- ② Cleaning agent tank
- ③ Rating plate
- ④ USB port

Baking chamber



- ① Top heat
- ② Spray nozzle (optional)
- ③ Tray supports, detachable
- ④ Suction plate, screwed on
- ⑤ Heat storage plate (optional)

Back

- ① Steam discharge connection
- ② Connecting power cable
- ③ Water connection
- ④ Rating plate
- ⑤ Baking chamber water drain
- ⑥ RJ-45 network interface (optional)
- ⑦ Connecting socket for data line between two ovens
- ⑧ Fitted socket for vapour hood with steam condenser (optional)
- ⑨ Equipotential bonding
- ⑩ Siphon (optional)

3.2.3. DUO model

Baking systems

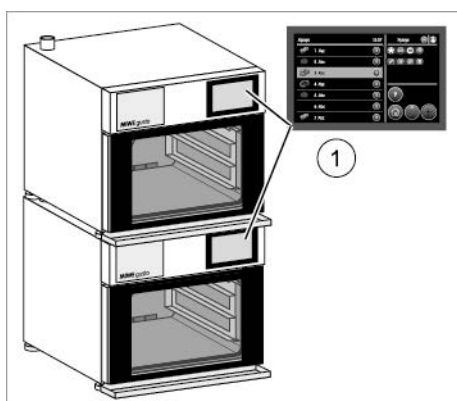


NOTE!

No additional MIWE gusto snack may be fitted to a MIWE gusto snack.

	Version 1	Version 2
Top oven	MIWE gusto	MIWE gusto
Bottom oven	MIWE gusto	MIWE gusto snack

Front section

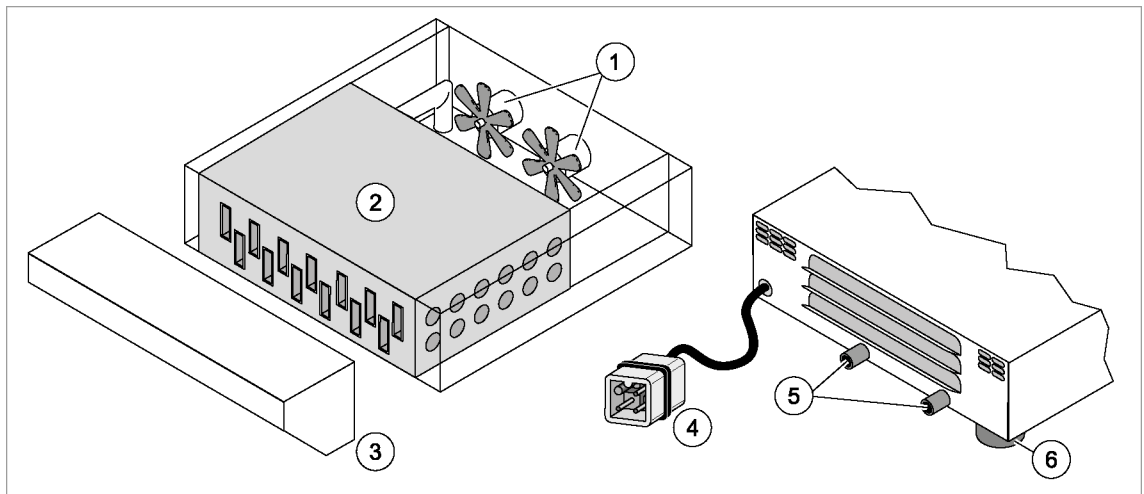


- ① Operating unit per baking chamber
For further information, please see 'Front section' in 'Single-circuit system'.

Back

For further information, please see 'Back' in 'Single-circuit system'.

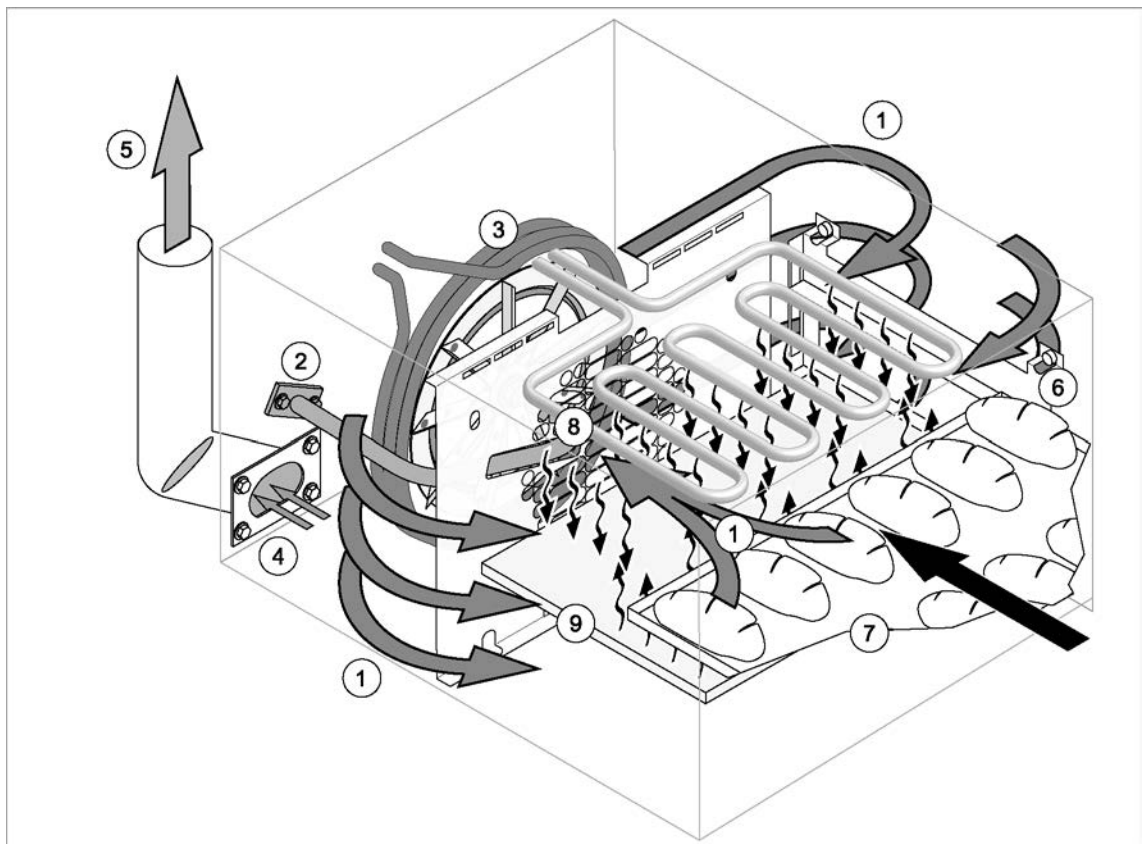
3.2.4. Vapour hood with steam condenser



- ① Fan
- ② Steam condenser
- ③ Vapour hood
- ④ Plug for power supply
- ⑤ Condensate drain connection
- ⑥ Steam input connection

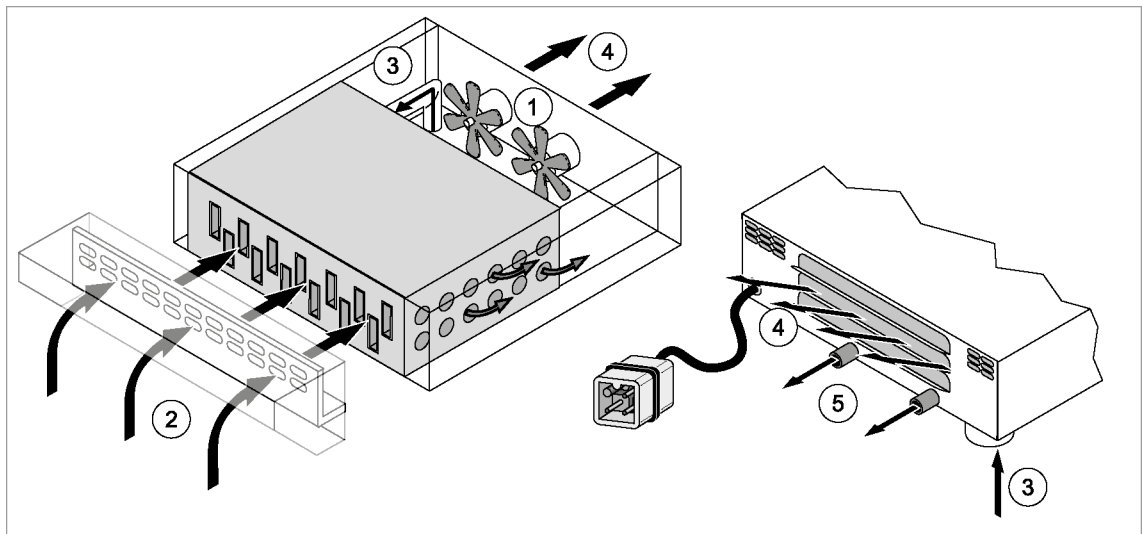
3.3. Functioning principle

3.3.1. Oven



- ① There is a central air intake in the baking chamber and the air is then circulated.
- ② Solenoid valve opens as required. Water is sprayed on the impeller and forms steam.
- ③ Electric heating elements heat up the air in the baking chamber and an impeller circulates the hot air in the baking chamber.
- ④ Steam outlet with valve
- ⑤ Steam is extracted from the baking chamber.
- ⑥ The tray supports can be easily removed for cleaning.
- ⑦ Loaded baking trays rest on tray supports.
- ⑧ Heating elements transfer heat to the products from above.
- ⑨ An optional heat storage plate transfers heat to the products from below.

3.3.2. Vapour hood with steam condenser



- ① The electric fans produce a defined negative pressure in the steam condenser housing.
- ② This negative pressure sucks ambient air into the vapour hood and steam condenser.
- ③ Excess steam is extracted from the baking chamber and into the steam condenser. There, the steam cools down and condenses.
- ④ The waste air is released into the surroundings.
- ⑤ Any condensate which forms runs through hoses into the siphon.

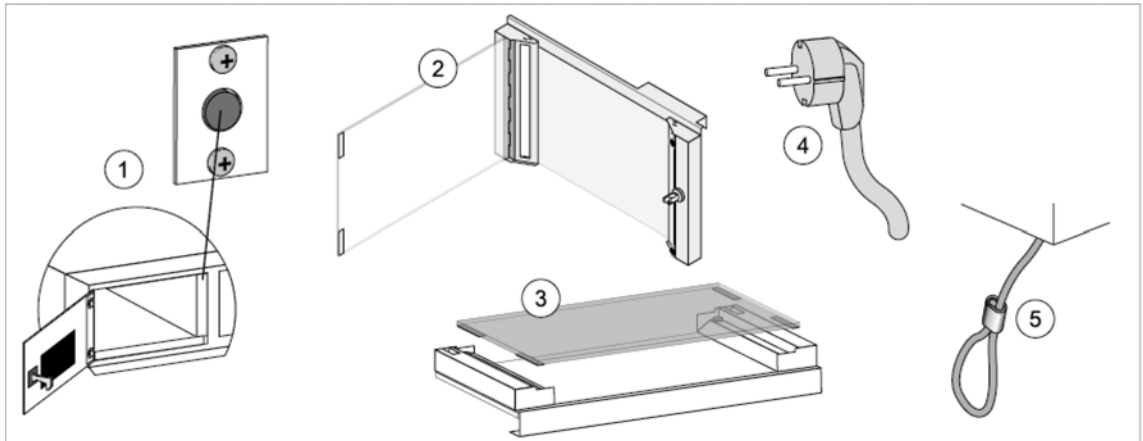
3.4. Safety devices



DANGER: RISK OF INJURY AND DAMAGE TO THE UNIT!

Changes to the safety devices can pose a safety risk and render the operating licence / warranty void.

- Never tamper with or make unauthorised adjustments to the safety devices.
- Any and all adjustments must be carried out by MIWE service.
- Document the subsequent acceptance and inspection and have these approved.



- | | |
|--|---|
| ① Safety temperature limiter | ④ Electrical plug and socket connection |
| ② Double glazing for model with side-hinged door | ⑤ Emergency release for model with side-hinged door |
| ③ Double glazing for model with bottom-hinged door | |

3.4.1. Multiple glazing, oven door

Prevents the front from getting hot.

3.4.2. Safety temperature limiter

Monitors the temperature in the baking chamber

If the preset maximum temperature is exceeded:

- the safety temperature limiter trips.
- the heating is switched off.
- the operating unit remains on.

3.4.3. Power connection

It must be possible to rapidly disconnect the power in the event of danger (with a plug and socket connection or master switch fitted by the owner-operator).

The power connection must be easily accessible at all times.

For further information, please see the "Essential preparations".

3.4.4. Emergency release

In an emergency, the emergency release must ensure that the baking chamber can be opened rapidly.

For further information, please see 'Faults – Opening the baking chamber with emergency release'.

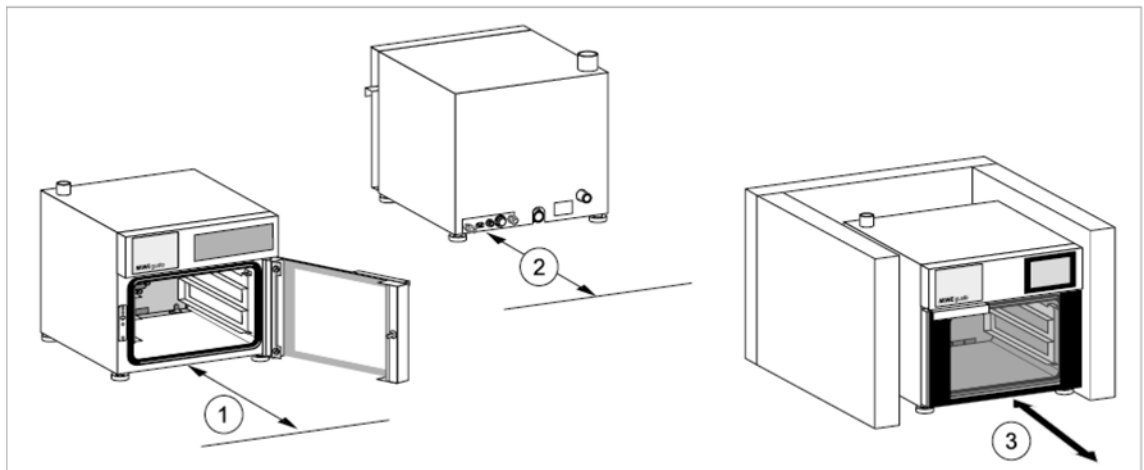
3.5. Description of work areas



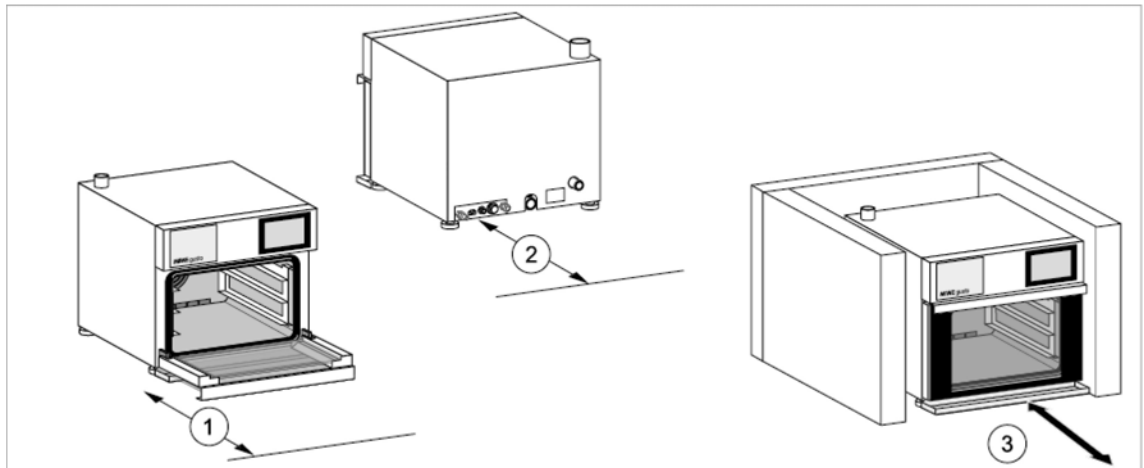
WARNING!

The work areas for operating, maintenance and cleaning personnel must not be obstructed by objects or fixtures.

Model with side-hinged door



- ① Work area for operating, maintenance and cleaning staff
- ② Work area for maintenance and cleaning personnel
- ③ Moving the unit

Model with bottom-hinged door

- ① Work area for operating, maintenance and cleaning staff
- ② Work area for maintenance and cleaning personnel
- ③ Moving the unit

3.5.1. Work area for operating personnel

The work area is located in front of the oven and has space for loading and unloading the oven. Recommended minimum work area depth: Total depth +50 cm.

3.5.2. Work area for maintenance and cleaning personnel

The work areas are located in front and at the back of the oven. If the unit is fixed or stands with its back against a wall, it will need to be moved for maintenance and cleaning. Move the unit using suitable lifting gear (forklift) or rotate it to ensure there is enough space to work.

Recommended minimum work area depth: Total depth +50 cm.

4. Installation by MIWE service



DANGER OF INJURY AND DAMAGE TO THE UNIT!

Installation must be carried out by trained, qualified personnel with the necessary experience (certified).

Errors in installation can result in life-threatening situations and cause serious damage.

- All installation work must be left to MIWE service or an authorised partner of MIWE service.
- Consult MIWE service or an authorised partner of MIWE service if the unit is subsequently to be moved.
- Work on the electrical equipment must be carried out by qualified electricians.
- Never modify or adjust the electrical or mechanical equipment or safety components.

5. Installation by owner-operator



WARRANTY

Responsibility for the unit is transferred to the owner-operator upon acceptance of the unit.

5.1. Safety information



DANGER: INCORRECT INSTALLATION CAN CAUSE INJURY AND DAMAGE THE UNIT!

Mistakes made during installation can result in potentially fatal situations or cause serious damage.

- All installation work must be carried out in compliance with the applicable regional and national laws and regulations.
- Work on the electrical equipment must be carried out by qualified electricians.
- Never modify or adjust the electrical or mechanical equipment or safety components.
- Consult MIWE service or an authorised partner of MIWE service if the unit is subsequently to be moved.



INCORRECT INSTALLATION CAN CAUSE INJURY!

Incorrect installation can result in serious injury to persons or damage to property.

- Before starting work, make sure there is sufficient space for installation and assembly.
- Handle sharp-edged components with care.
- Make sure the work area is sufficiently well lit.
- Make sure that the work area is clean and tidy.
Loosely piling components and tools or leaving them lying around can cause accidents.
- Fit components properly. Observe the specified tightening torques.
- Secure components so that they do not fall or topple.

5.2. Installation preparations



NOTE!

For further information on installation, please see 'Important information' and 'Safety'.

For further information on the materials required, please see the 'Essential preparations'.

This document is sent to the owner-operator together with the order confirmation.



1. Make sure that the conditions specified in the 'Essential Preparations' are met.
2. Wear the prescribed protective clothing for all work.
3. Unpack the unit and remove all protective film.
4. Check that there are no foreign objects in the unit.

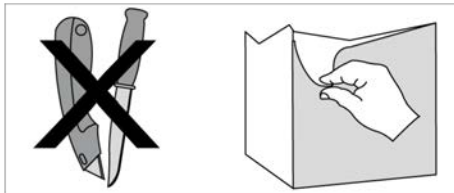
5.2.1. Removing protective film



CAUTION: INCORRECT REMOVAL OF THE PROTECTIVE FILM CAN CAUSE DAMAGE!

Using sharp or pointed tools can damage the unit.

- Remove the protective film by hand.



5.3. Positioning the components

The floor/foundation must be designed to bear the weight of the component.



CAUTION: OVERLOADING CAUSES DAMAGE!

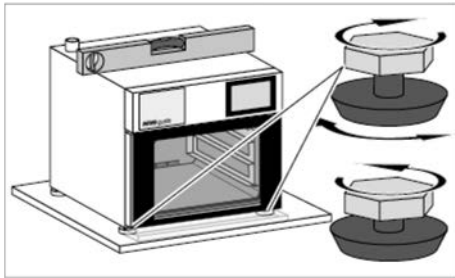
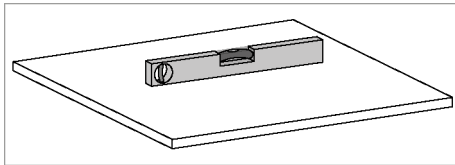
Too heavy a load can damage the floor/foundation.

- Check the load-bearing capacity of the floor/foundation.
- Prepare floor/foundation in accordance with load-bearing capacity.



NOTE!

Remember to allow for the weight of the dough and baking trays.



1. Place component on a flat surface.
2. Position the component flat.
 - Loosen locknut on the front adjustable feet with a suitable tool.
 - Screw the adjustable feet up or down until the component is level.
 - Tighten the locknut with a suitable tool.



NOTE!

There must be a minimum space of 30 mm between the bottom of the oven and the floor/foundation.

Adjust the base frame and intermediate compartment in the same way.

5.4. Connecting the components



EXCEEDING THE MAXIMUM UNIT HEIGHT CAN CAUSE INJURY!

The unit may tip over and cause injury and material damage if the maximum permitted unit height is exceeded.

- For details, please see the technical data.



CAUTION: COMPONENT WEIGHT CAN CAUSE DAMAGE

If you connect multiple components, you may overload the unit.

- Check the load capacity.
- Only install components approved by MIWE.

CAUTION: INSTALLING THE WRONG COMPONENTS CAN CAUSE DAMAGE!

Combinations with non-MIWE units can cause damage.

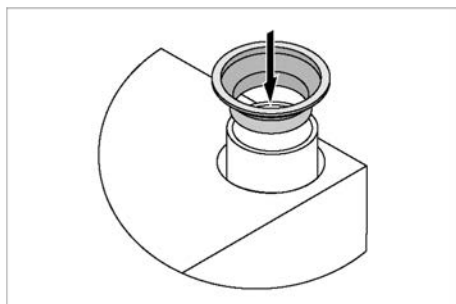
- Only install components approved by MIWE.
- Contact MIWE service if in doubt.

5.4.1. Two ovens, one above the other

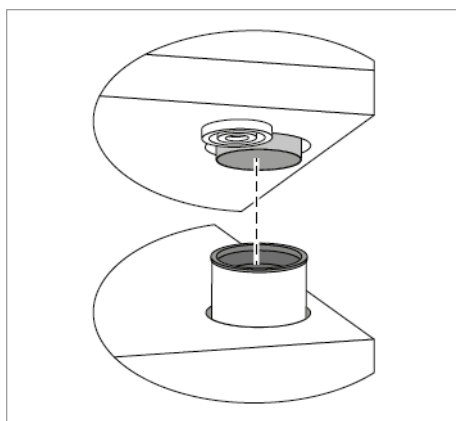


NOTE!

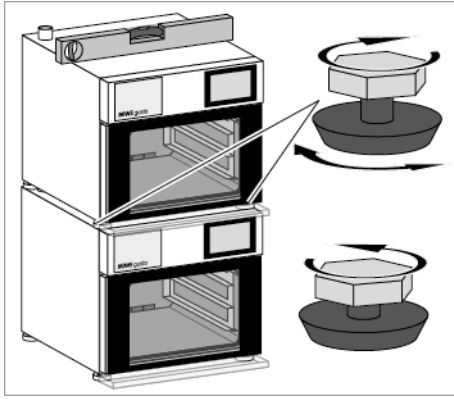
Always fit the oven with steam outlets at top and bottom as the top oven.



1. Grease the sealing ring with standard, food-safe grease.
Now fit the steam outlet of the bottom oven.



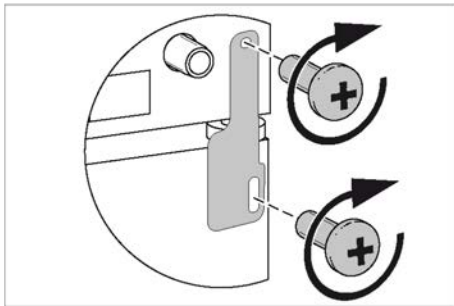
2. Place the top oven on the bottom oven. The steam ducts must fit together exactly, and the sealing ring must not slip.



3. Position the oven flat:
 - Loosen locknuts on the front adjustable feet with a suitable tool.
 - Screw the adjustable feet up or down until the oven is level.
 - Tighten the locknuts with a suitable tool.

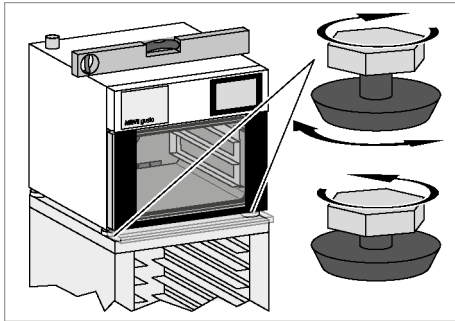
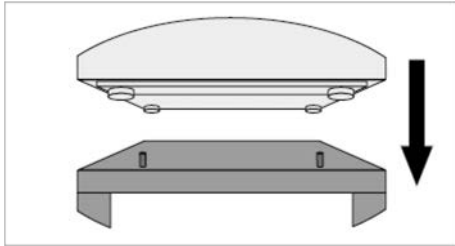
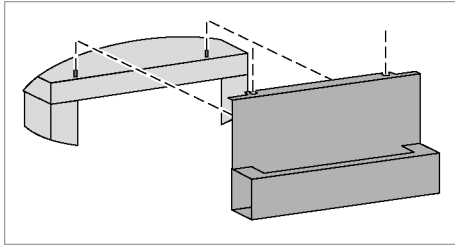
**NOTE!**

There must be a minimum space of 30 mm between the two ovens.



4. Connect the ovens at the back with two mounting plates.
Tighten screws with a suitable tool.

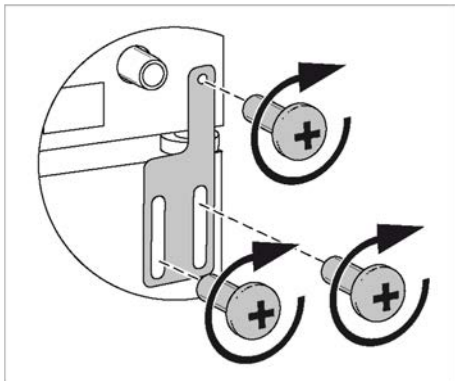
5.4.2. Oven with base units



1. For models with siphon:
attach siphon bracket to the stud bolts
2. Position the oven on the base unit.
3. Position the oven flat.
 - Loosen locknuts on the front adjustable feet with a suitable tool.
 - Screw the adjustable feet up or down until the oven is level.
 - Tighten the locknuts with a suitable tool.

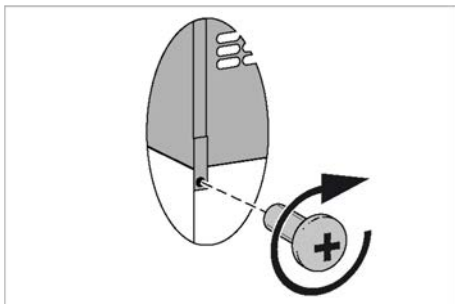
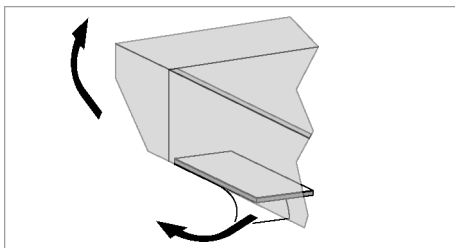
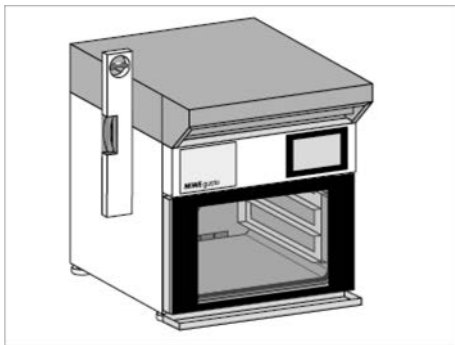
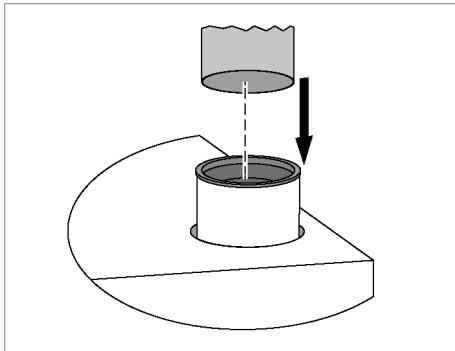
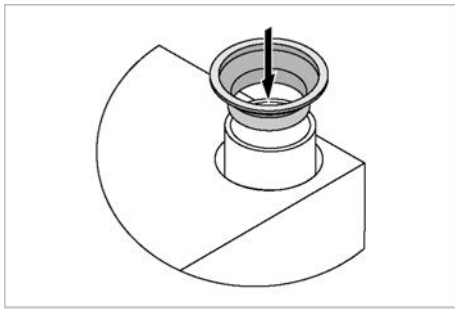
**NOTE!**

There must be a minimum space of 30 mm between the bottom of the oven and the base unit.



4. Connect the oven and base unit at the back with two mounting plates.
Tighten screws with a suitable tool.

5.4.3. Vapour hood with steam condenser on oven



1. Grease the sealing ring with standard, food-safe grease.
Now fit the steam outlet of the oven.

2. Place the vapour hood with steam condenser on the oven. The steam ducts must fit together exactly, and the sealing ring must not slip.

3. Align the faces and edges of the vapour hood with steam condenser with the oven.

4. Lift up the vapour hood with steam condenser slightly at the front.
Remove the protective film from the adhesive surfaces at the front of the underside of the vapour hood.
Push down the vapour hood.

5. Connect the vapour hood with steam condenser and the oven at the back with two mounting plates.
Tighten screws with a suitable tool.

5.5. Electrical system



RISK OF ELECTROCUTION!

Contact with live parts can kill.

Damage to the insulation or individual components can cause death.

- Always have work on electrical equipment carried out by qualified electricians.
- Before any work, switch off the power supply to the unit and make sure it cannot be switched back on, and check that no parts are live.
- Protect live parts from moisture.
Moisture can cause electric shocks and short-circuiting.
- Have damaged insulation repaired.
- Never bypass or disable safety devices such as fuses or safety thermostats.
- Observe the correct amperage and characteristics when replacing fuses.
- Lay the connecting power cable so that it is not kinked or pinched.
- If the unit is to be disconnected from the power supply, unplug the connector.

5.5.1. Connecting the oven



WRONG CABLE DIMENSIONS CAN CAUSE FIRE!

An insufficient power cable cross-section can lead to the cabling overheating. This can cause a short circuit causing serious damage to or completely destroying the unit, or even a fire in the bakery.

- Never connect more than one unit to a socket with earthing contact.
- Do not use extension cables.
- Do not use power strips.
- If in doubt, seek the advice of a qualified electrician.



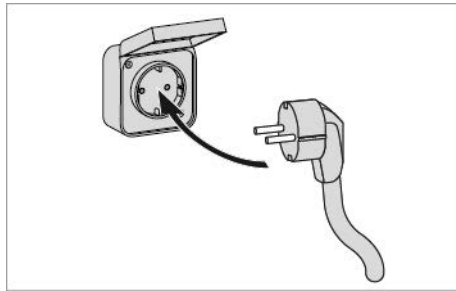
WARNING: SAFETY COMPONENT – ELECTRICAL PLUG AND SOCKET CONNECTION

Electrical plug and socket connections are safety components and ensure the rapid disconnection of power in the event of danger.

- Do not replace electrical plug and socket connections with fixed power connections.



CE EAC MIWE	
type	year of manufacture
serial-no.	country
rated voltage (V)	nominal consumption (kWh)
frequency (Hz)	rated heat load (kW)
product ID-no.	connection pressure (Pa)
fuel	category
<small>MIWE Michael Wenz GmbH · D-97450 Arnstein · Germany · +49-09363-680</small>	



1. Make sure that the owner-operator power ratings correspond to those on the rating plate.
2. Connect plug with earthing contact to socket with earthing contact.

5.5.2. Connecting the vapour hood with steam condenser



NOTE!

At the back of the oven is a fitted socket for an optional vapour hood with steam condenser.

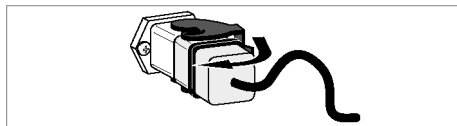
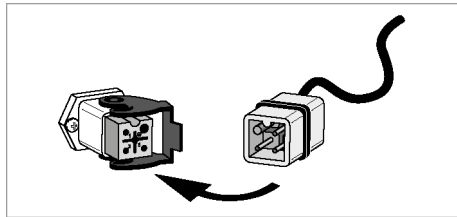
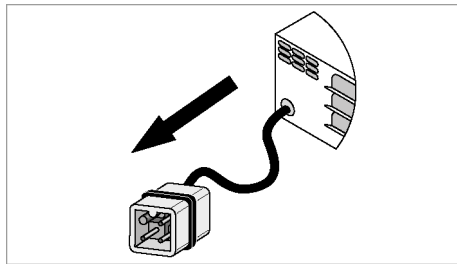
Fitted sockets can only be retrofitted by MIWE service.



CAUTION: INCORRECT POWER CONNECTION CAN CAUSE DAMAGE!

Incorrect connection to the power supply can lead to damage.

- Only ever connect the vapour hood with steam condenser to the oven fitted socket.
- Only install components approved by MIWE.
- Check the installed loads for the device socket.
Do not connect units with higher installed loads.

Steam condenser

1. Grip the plug and carefully pull the cable out of the unit until it is long enough.

2. Connect the plug to the fitted oven socket.

3. Close the clip on the fitted socket

**NOTE!**

The steam condenser is automatically switched on and off and is controlled by the oven.

5.6. Water supply**CAUTION: HOT WATER CAN CAUSE DAMAGE!**

- Only connect cold, potable water.

USING THE WRONG HOSES CAN DAMAGE THE UNIT!

Particles of plastic or rubber may come off if the wrong hoses are used. These particles can damage the unit.

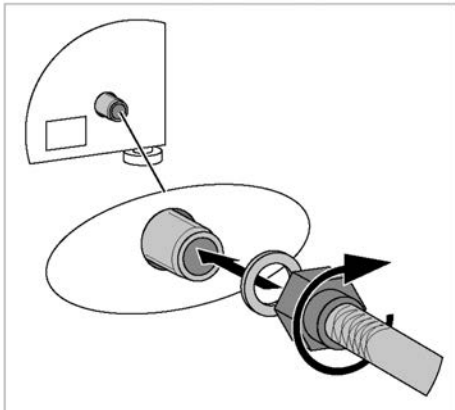
Drinking water supply lines must therefore:

- Be approved for use in the food sector.
- Be suitable for ambient temperatures of at least 80°C.
- Be suitable for water pressure of 6 bars.

5.6.1. Connecting the water supply line



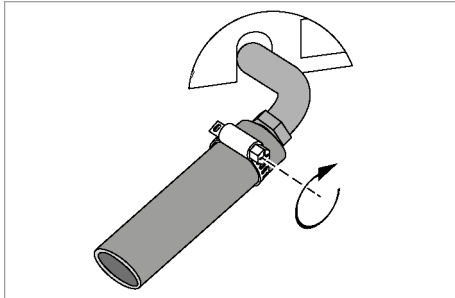
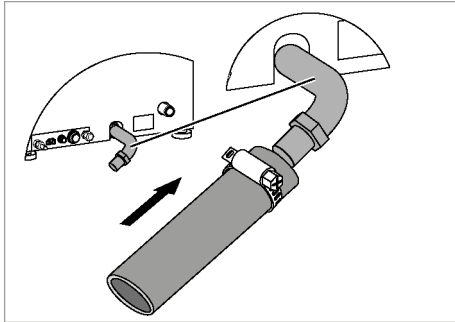
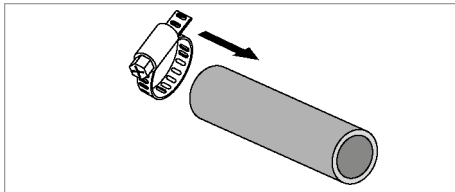
1. Close the shut-off valve in the water supply line installed by the owner-operator.
2. Screw the end of the water supply hose firmly onto the thread of the water supply line installed by the owner-operator.
3. Lay a sufficient length of water supply hose to the oven.
It must be possible to move the oven for cleaning and maintenance.



4. Screw the union nut on the water supply hose onto the thread of the water connection piece.
Be careful with inserted seals.
5. Open the shut-off valve in the water supply line installed by the owner-operator.
6. Check (visual check) for water leaks.

5.7. Water drain

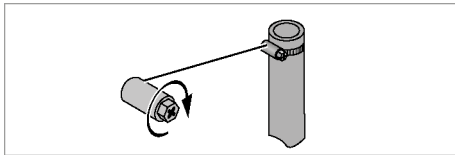
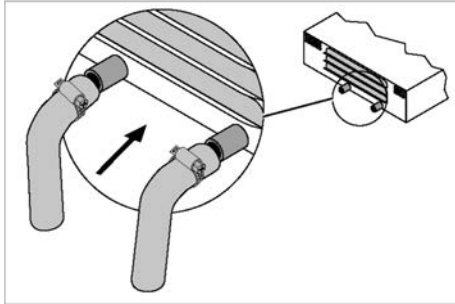
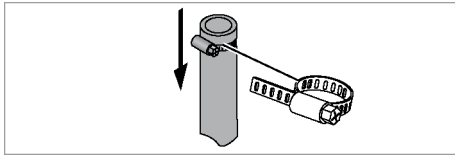
5.7.1. Connecting the water drainage hose to the oven



1. Push the hose clamp onto the water drainage hose 1 cm from the end of the hose.
2. Attach the hot water/steam hose with hose clamp to the baking chamber water drain connection.
3. Tighten the hose clamp screw with a suitable tool.

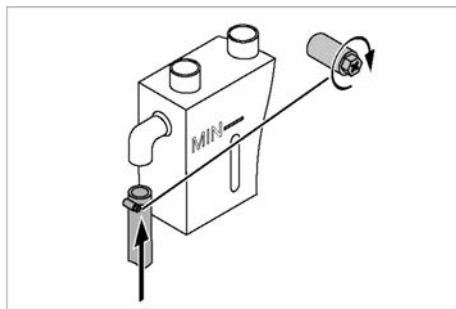
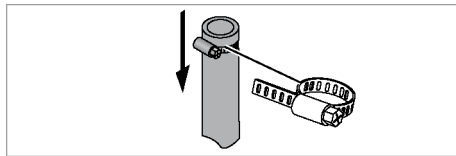
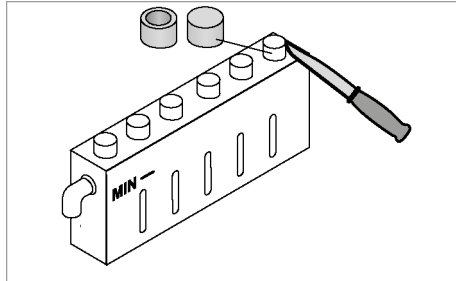
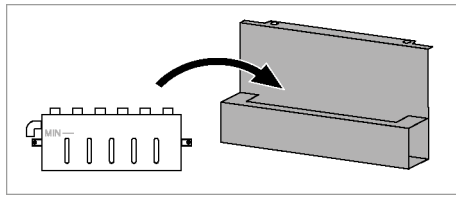
5.7.2. Connecting the condensate hoses

Steam condenser



1. Push the hose clamps onto the water drainage hoses 1 cm from the end.
2. Push drainage hoses onto the condensate drain connections.
3. Tighten the hose clamp screw with a suitable tool.

5.7.3. Fitting the siphon (optional)



1. Place siphon in siphon bracket.
2. Open the required holes with a suitable tool. Start at the opposite side of the drain.
3. Push the hose clamp onto the water drainage hose 1 cm from the edge.
4. Push water drainage hose onto water drain. Tighten the hose clamp screw with a suitable tool.

5.7.4. Draining water and condensate

There are a number of ways to drain off the water and condensate through the drainage hoses.

Siphon drainage

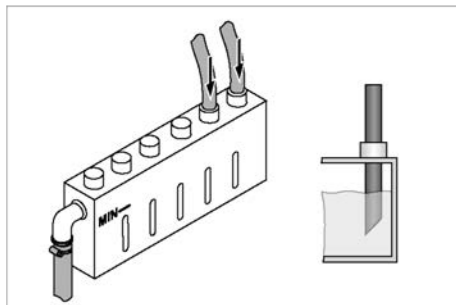
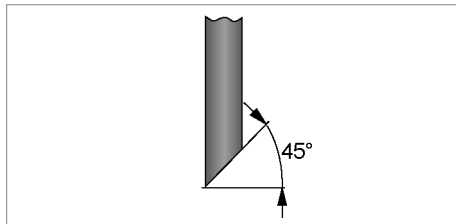
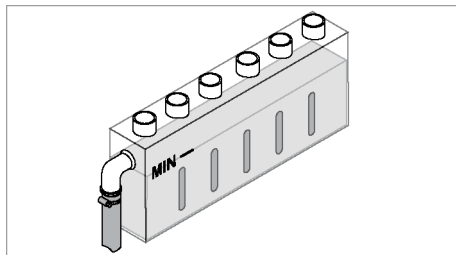


WARNING!

For units with automatic cleaning systems, the baking chamber drainage hose must be laid straight to a siphon with an odour trap and without a water pocket (siphon to be provided by owner-operator).

The wastewater must in this case not be piped to an open container.

For units with steam condensers, lay the drainage line to a siphon.



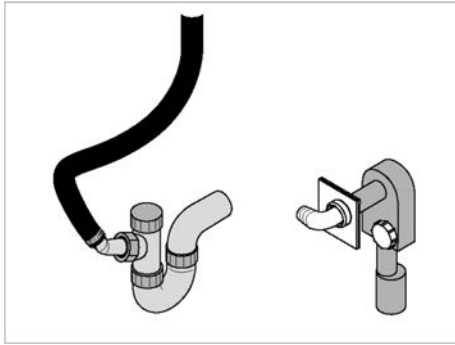
1. Fill the siphon with water up to the MIN mark.
2. Cut the drainage hoses at 45° with a suitable tool.
3. Push the drainage hoses down to c. 2 cm from the bottom of the siphon.



CAUTION: DIRT CAN CAUSE DAMAGE!

If the steam condenser (optional) drainage hoses are in the siphon, they can get dirty over time and affect the flow.

- Make sure when inserting the drainage hoses into the siphon that they are above the water drain.



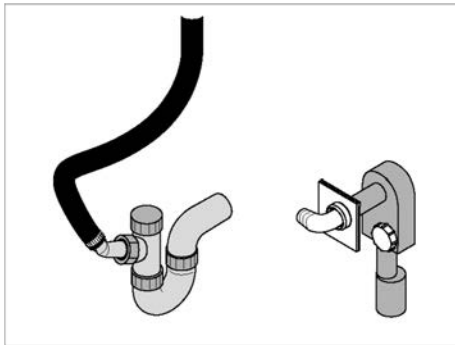
4. Lay water drainage hose to steam-tight/watertight siphon with odour trap.

or

4. Lay water drainage hose to concealed siphon with odour trap and cleaning opening.

Drainage to drain installed by owner-operator

Lay drainage hoses of a sufficient length to drain installed by owner-operator.
It must be possible to move the oven for cleaning and maintenance.



1. Lay water drainage hose to steam-tight/watertight siphon with odour trap.

or

1. Lay water drainage hose to concealed siphon with odour trap and cleaning opening.

Drainage into an open container

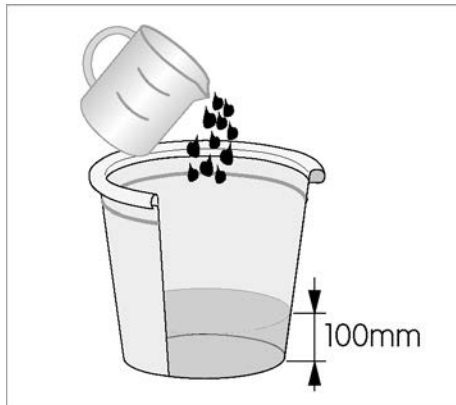
If there is no site drain, the water should be collected in a suitable tank or container resistant to temperatures of up to 90°C.



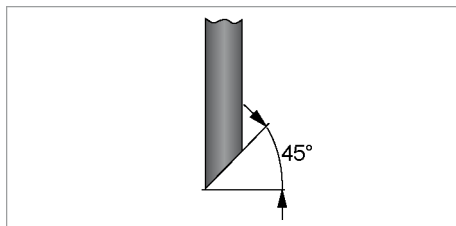
RISK OF INJURY FROM HOT STEAM!

Escaping hot steam can scald and cause damage.

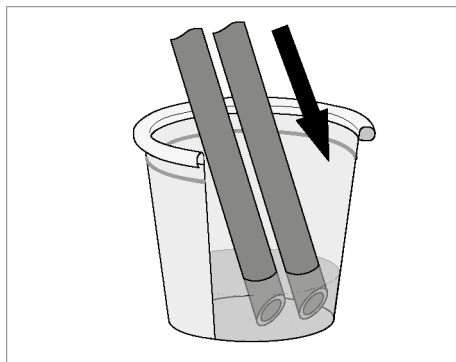
- Fill container with drinking water before installation – up to at least 100 mm.
- Make sure that the ends of all the hoses in the container are under the water.
- Always check and if necessary empty container before starting to bake.



1. Fill container with water up to at least 100 mm.



2. Cut the drainage hoses at 45° with a suitable tool.



3. Push the drainage hoses down to c. 2 cm from the bottom of the container.

5.8. Steam



POOR AMBIENT CONDITIONS CAN CAUSE INJURY!

Discharging steam into the surrounding area/bakery can create unpleasant ambient conditions for personnel due to condensate and heat.

- Steam must be piped outside through discharge lines installed by the owner-operator.
- Discharge lines must always be straight and laid at an angle.
- Install discharge lines made of stainless, steam-tight and non-flammable material which is resistant to temperatures of up to 180°C.
- If it is impossible to discharge the steam to the outside for structural reasons, install a steam condenser with vapour hood on the unit.



CAUTION: OVERPRESSURE AND NEGATIVE PRESSURE CAN CAUSE MATERIAL DAMAGE!

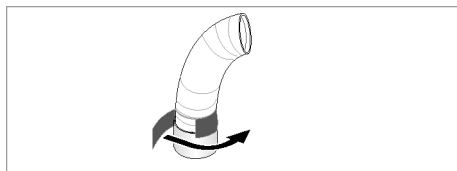
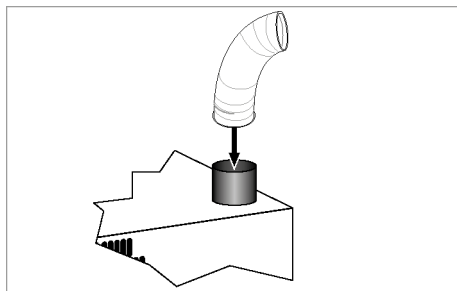
Overpressure and negative pressure caused by excessively long pipes, the wrong pipe diameter or backflow can cause damage to the unit and / or lead to poor results.

- A negative pressure of 0.1 mbar is standard.
- The negative pressure may briefly be 0.2–0 mbar.
- Make sure that the waste air can escape freely to the outside.
- Protect the waste air outlet from rain, snow and wind.
- Ensure the area around the unit is sufficiently ventilated.
- Contact qualified personnel if required.

5.8.1. Connecting the steam outlet

The steam discharge connection is at the top of the unit.

If the unit is not combined with a vapour hood with steam condenser, the steam must be piped outside through discharge lines.



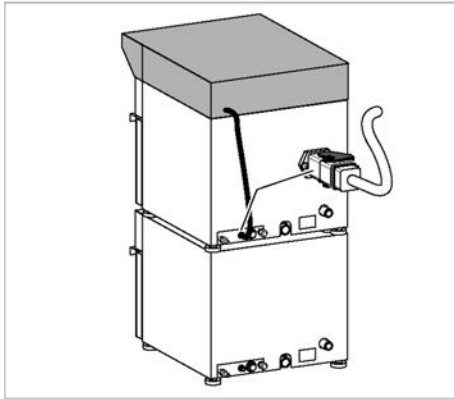
1. Push one end of the flexible pipe into the steam discharge connection from the top.
2. Seal the joint with the flexible pipe with adhesive metal tape.
3. Connect the other end of the flexible pipe to the discharge line to the outside installed by the owner-operator and seal with adhesive metal tape.

5.9. Connecting the data line between two ovens

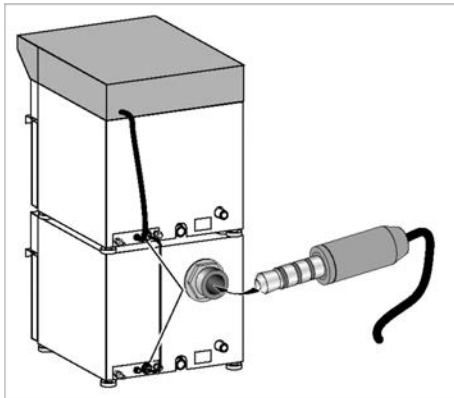


NOTE!

Once the data line is connected, the steam condenser is automatically switched on and off and is controlled by the active oven.



1. Check electrical connection.



2. Connect the two ovens to the two data line jack plugs.

6. Commissioning by MIWE service

6.1. Commissioning



NOTE!

Before commissioning, you must make sure that installation is correct and complete.

The manufacturer provides the following services to the owner-operator as part of commissioning:

- Inspection of the electrical and mechanical equipment and the safety devices.
- Trial operation in cooperation with the owner-operator.
- Training
- Handover of the unit to the owner-operator with a handover report.

6.1.1. Training

Instruction and training by the manufacturer begins after successful trial operation. Instruction and training is provided for:

- Operating personnel
- Maintenance personnel

6.1.2. Handover to the owner-operator with a handover report

Following successful trial operation, instruction and training, the unit is handed over to the owner-operator. The following services are provided:

- Handover of complete documentation.
- Completion of the handover report and signature by the owner-operator and the manufacturer.

This handover report remains an integral part of the complete documentation.



WARRANTY

Responsibility for the unit is transferred to the owner-operator upon handover and signature of the report.

7. Commissioning by the owner-operator

7.1. Safety information



DANGER OF INJURY AND DAMAGE TO THE UNIT!

The unit as a whole may only be commissioned if it complies with the national and regional standards governing house service connection facilities and heat transfer systems.

7.2. Commissioning



NOTE!

Before commissioning, you must make sure that installation is correct and complete.

7.2.1. Checking the mechanical and electrical devices

Check the following are working properly:

- Water supply and discharge
- Electrical connection
- Safety devices
- Steam outlet

7.2.2. Trial operation

Carry out a test run after baking out.

Check the following are working properly:

- Baking process
- Adjustment and calibration of the individual units
- Sensor temperature adjustment

7.2.3. Training

Instruction and training by the owner-operator begins after successful trial operation.

Instruction and training is provided for:

- Operating personnel
- Cleaning personnel
- Maintenance personnel

7.3. MIWE cleaning control cleaning program

7.3.1. Safety information

**CAUTION: USING THE WRONG CLEANING AGENT CAN CAUSE DAMAGE!**

Using a cleaning agent other than that specified by MIWE can cause material damage.

- Only use the specified cleaning agent.

**WARNING: OBSERVE THE INFORMATION ON THE SAFETY DATA SHEET!**

Access the relevant safety data sheet from the MIWE homepage.

- Go to www.miwe.com / Service / Sicherheitsdatenblätter.
- Enter the item number given on the spare parts list.
- Select country of use.

7.3.2. Filling the cleaner tank

**NOTE!**

For further information, please see 'Cleaning and care', 'MIWE cleaning control cleaning program', 'Filling up the cleaning agent'.

8. Operation

8.1. Safety instructions



INCORRECT OPERATION CAN CAUSE INJURY!

Incorrect operation can result in serious injury and damage.

- Always read the relevant section of this instruction handbook before each stage in operation.
- Carry out all steps according to the instructions in this instruction handbook.
- Only allow trained personnel to operate the unit.



DEFECTS IN THE UNIT CAN CAUSE INJURY!

Defects in the unit can result in serious injury and damage.

- Check the unit for visible defects before switching it on.
- If you find any defects, immediately disconnect the unit from the power supply and contact MIWE service.



BAKING CHAMBER DANGEROUS FOR PEOPLE AND ANIMALS!

The high temperatures inside the baking chamber pose a danger to life.

- Always make sure that there are no persons or animals in the baking chamber before starting to bake.



CRUSH HAZARD WHEN OPENING AND CLOSING DOORS!

You may injure yourself when opening and closing doors improperly.

- Wear the prescribed protective clothing for all work.
- Use the door handle.



CAUTION: DAMAGE TO THE SURFACE OF THE OPERATING UNIT!

Sharp objects may damage the surface of the operating unit.

- Only operate the operating unit with your hands.



NOTE!

Always observe the specific safety instructions for each operation!

Protective clothing

Protective clothing must be worn for work to minimize health risks.



PROTECTIVE CLOTHING

- To protect from burns from hot surfaces and vapour. Protective clothing must have long sleeves and long legs.



PROTECTIVE GLOVES






- To protect the hands from burns from hot surfaces and vapours and from rubbing, grazing, jabbing or deeper wounds.







SAFETY GOGGLES

- To protect the eyes from splashes and hot vapours.

8.2. Operating modes

	Baking	<ul style="list-style-type: none"> • Baking with baking programs • Manual change (not as EASY user)
	OFF mode	<p>This function prevents accidental activation.</p> <ul style="list-style-type: none"> • Baking not possible. <p>Requirement for:</p> <ul style="list-style-type: none"> • AUTOSTART • Automatic cleaning
	AUTOSTART	The unit switches on automatically and is ready to bake at the set autostart time.
	MIWE Eco-Modus	The energy-saving function reduces the energy consumption of the unit when it is switched on but not in continuous use. The temperature in the baking chamber is kept at a constant, reduced level.
	Cleaning	<p>The baking chamber is cleaned or descaled with an automatic program.</p> <p>Five different programs are available to choose from.</p>

8.3. User selection

	EASY	<ul style="list-style-type: none"> • Baking with baking programs • Access to the most important functions
	PROFI	<ul style="list-style-type: none"> • Baking with baking programs and manual changes • Advanced settings • Detailed displays • Baking program creation and editing
	ADMIN	All rights are available.
	SERVICE	Only for MIWE service or qualified personnel authorised by MIWE.

8.3.1. Changing users



1. Touch the USER button.
The display changes in line with the selected user.



2. Touch the required button.
The current mode will be displayed.

Further information



1. Touch the HELP button.
A menu with additional information will open.

8.4. MIWE TC controls (Touch Control)

The controls are operated using a touch-screen on the front.



Switch the power ON.

- The user interface will appear on the screen after c. 20 seconds.

Different buttons and parameters will appear depending on the mode and operation.

8.4.1. About the operating unit

The screen has a touch-sensitive surface.

All entries and settings are made on the screen.



NOTE!

If the screen does not respond when touched or implements a function for a button other than the one touched, the screen needs to be recalibrated.

For further information, please see 'Recalibrating the screen'.



NOTE!

You can switch between different views by swiping.

8.5. Ready for operation

Establishing operating status



1. Open the cold water supply line.
2. Check the electrical connection is secure and undamaged.
3. Check for damage to waste water and ventilation system.
4. Switch power supply ON.



CAUTION: FOREIGN OBJECTS CAN CAUSE DAMAGE!

Foreign objects can melt or burn and damage the unit.

- Make sure that there are no foreign objects inside the unit before switching it on.

Ending operating status



1. Close the cold water supply line.
2. Switch the controls OFF.
3. Disconnect the unit power supply.

8.6. Switching the controls ON / OFF

Switching the controls ON



1. Touch the ON / OFF button until the illuminated circle around the button appears in full.
The background colour of the button will change to yellow.

- All displays are active.
- All buttons can be operated.
- The oven will heat up.



NOTE!

The controls will automatically load the values set when they were last switched off. Provided no baking process has been started, the controls can be switched off by touching the STOP button.

Switching the controls OFF



1. Touch the STOP button.
The CANCEL menu will open.



2. Touch the ON / OFF button.
The controls will switch to OFF mode.

8.7. OFF mode

OFF mode means the power is ON and the controls are OFF.

- The operating unit is locked in OFF mode.
- Buttons can be touch-operated.



1. Switch the controls OFF.



HELP button

Menu with additional information about the current process.
Touch until the illuminated circle around the button appears in full.



ON / OFF button

Activates the last mode selected.
Touch until the illuminated circle around the button appears in full.

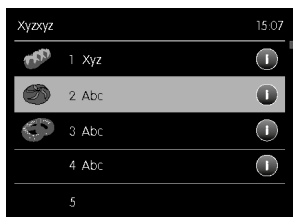
8.8. AUTOMATIC MODE

Baking programs automate the baking process and ensure consistently high product quality. You can bake with baking programs as an EASY or PROFI user. The following baking process is for EASY users.

Requirement:

- The controls are ON.
- There are no faults pending.

8.8.1. Selecting a baking program



1. Select the required baking program from the list.
 - The oven will start heating or cooling to the setpoint temperature.
2. Select the CONTINUE button.
3. Wait until ready to bake.
 - Do not load the oven.

8.8.2. Ready to bake

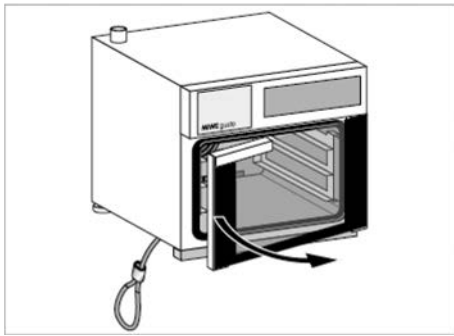
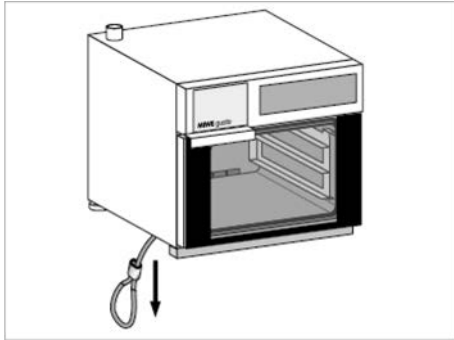
If the oven has reached the values set in the baking program, it is ready to bake.

'Ready to bake' is signalled as follows:

- A signal sounds.
- The temperature symbol flashes.
- Animation of loading the oven is shown.

8.8.3. OPEN / CLOSE baking chamber door – model with side-hinged door

Opening the baking chamber door



1. Touch the OPEN DOOR button.
The door will open automatically.

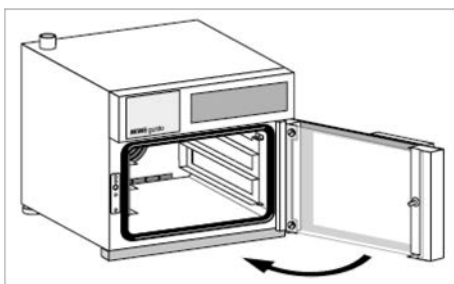
or

1. Pull down the emergency release.
The door will open automatically.

2. Open the baking chamber door completely by the handle.

The DOOR OPEN display will appear.

Closing the baking chamber door



1. Push the baking chamber door by the handle until you hear it slot into place.
The DOOR OPEN display will go out.

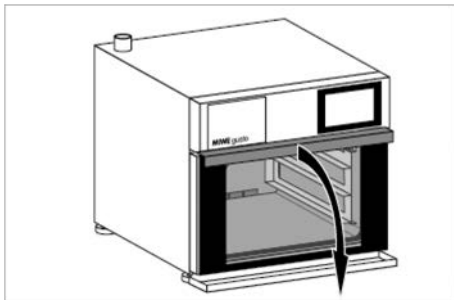


NOTE!

If the DOOR OPEN display does not go out, the closing process must be repeated.

8.8.4. OPEN / CLOSE baking chamber door – model with bottom-hinged door

Opening the baking chamber door

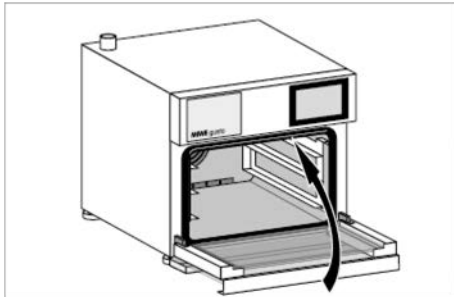


1. Pull the baking chamber door down by the handle.



The DOOR OPEN display will appear.

Closing the baking chamber door



1. Close the baking chamber door by the handle.
The DOOR OPEN display will go out.



NOTE!

If the DOOR OPEN display does not go out, the closing process must be repeated.

8.8.5. Loading the oven



NOTE!

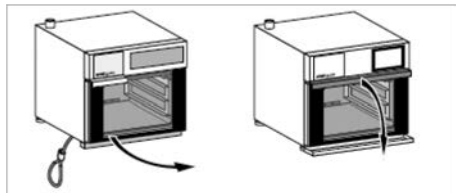
The first time the oven is heated each day, wait 10 to 15 minutes after 'ready to bake' before loading it.



1. The high temperatures inside the baking chamber pose a burn hazard.
 - When opening doors of the unit, ensure you are well away from the opening.
 - Keep the doors closed when the unit is unattended.



2. Wear the prescribed protective clothing for all work.



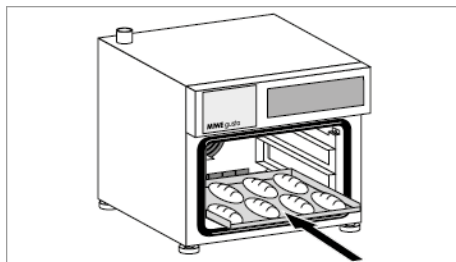
3. Open the baking chamber door.
When you open the baking chamber door, the vapour hood fan automatically switches ON.



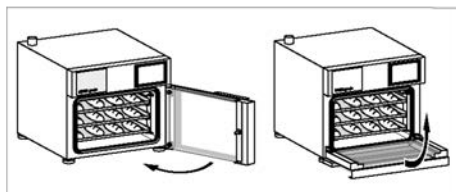
WARNING: SWARF IS A HEALTH RISK!

The baking trays and tray supports can rub against each other and produce swarf. Swarf is a health risk.

- Push the baking trays in straight.



4. Push in the loaded baking trays on the tray supports.
Load the oven starting from the bottom.



5. Close the baking chamber door.
The vapour hood fan switches OFF after 10 seconds.

8.8.6. Starting the baking process



1. Touch the START button.
2. Wait for remaining baking time of 00:00:00 and end of baking signal.

8.8.7. Cancelling the baking process



1. Touch the STOP button.
A sub-menu with cancellation options will open.



2. Touch the STOP button.

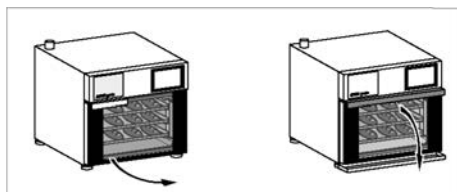
8.8.8. Unloading the oven



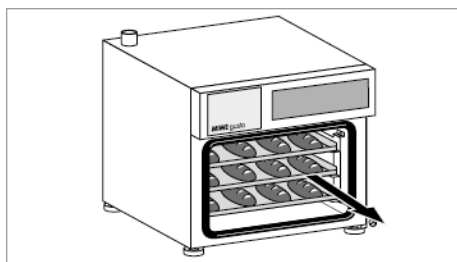
1. The high temperatures inside the baking chamber pose a burn hazard.
 - When opening doors of the unit, ensure you are well away from the opening.
 - Keep the doors closed when the unit is unattended.



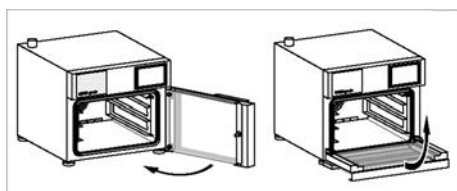
2. Wear the prescribed protective clothing for all work.



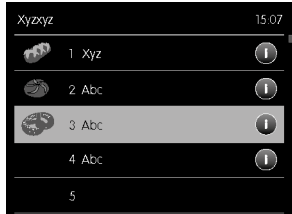
3. Open the baking chamber door.
When you open the baking chamber door, the vapour hood fan automatically switches ON.



4. Remove the baking trays and place them on a heat-resistant surface.



5. Close the baking chamber door.
The vapour hood fan switches OFF after 10 seconds.



6. Wait until ready to bake and then start the next baking process.

or

6. Select a different baking program from the list.

or

6. Touch the STOP button and switch the oven to the following mode:
- MIWE Eco-Modus
 - OFF mode

8.9. Managing baking programs

This menu allows you to create, change, copy, paste and delete baking programs.



1. As a PROFI user, touch the MAIN MENU button. The MAIN MENU will open.

2. Touch the PROGRAMS button in the SETTINGS section. The MANAGE PROGRAMS menu will open.

Further information



1. Touch the HELP button.
A menu with additional information will open.

Each line can be used as the memory location for a new baking program.
The baking programs used can be saved under the program numbers 1 to 250 for direct selection.
The baking program currently selected is highlighted in yellow.

8.9.1. Creating and changing baking programs

There are two ways to create a new baking program:

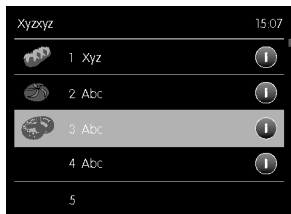
- Selecting an empty memory location and creating a completely new baking program.
- Copying an existing baking program to an empty memory location, changing it and saving it under a new name.



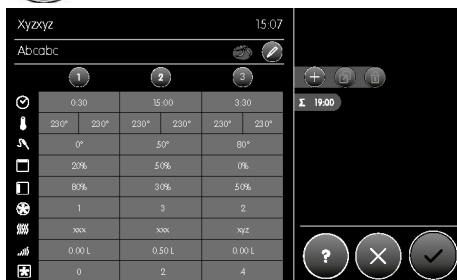
1. Touch the PROGRAMS button in the MAIN MENU.
The MANAGE PROGRAMS menu will open.

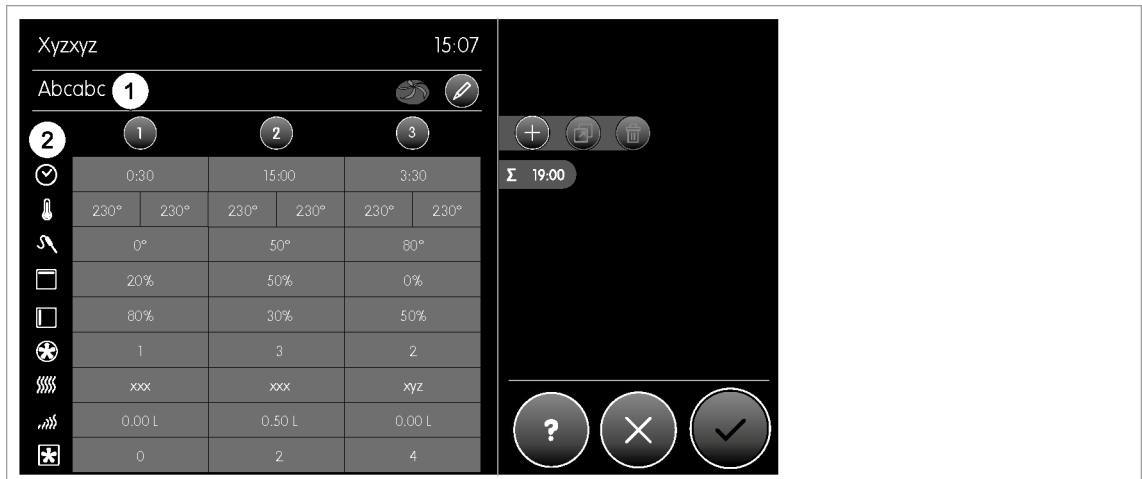


2. Touch the memory location of the baking program in the list.



















3. Touch the CHANGE PROGRAM button.
This will open the CHANGE PROGRAM menu.





Display Button	Explanation		
①	Display	Name of baking program	
	Button	Opens alphanumeric keypad for entering a name.	
②	Symbols for individual baking parameters		
		Duration of baking phase in minutes and seconds	
		Left	Setpoint temperature of baking chamber at start of baking phase.
		Right	Setpoint temperature of baking chamber at end of baking phase.
		Setpoint core temperature The current baking phase automatically ends when the setpoint core temperature is reached.	
		Top heat setting	
		Fan heat setting	
	The total top heat and fan heat setting can be a maximum of 100%.		
		Circulating fan setting 0 OFF 4 Maximum setting	
		Normal	Steam input at the start of the baking phase.
Frozen dough		Even steam input throughout the entire baking phase	
Gastro		Even humidification during the baking phase	

Display Button	Explanation	
		Steam quantity Normal and frozen dough steam type: Steam quantity setting in litres Gastro steam type: Humidity setting in %
		Vapour hood fan setting 0 OFF 4 Maximum setting
	The PRODUCT IMAGE button opens a menu. Touch the product image for the baking program. The product image is saved for the baking program.	
	EDIT button Opens the EDIT PRODUCT menu.	
		The PRODUCT IMAGE button opens a menu. Touch the product image for the baking program. The product image is saved for the baking program.
		The PRODUCT NAME button opens an alphanumeric keypad for entering a name.
		The PRODUCT INFO button opens a menu for entering product information.
		FLEXBAKE button MIWE flexbake: capacity regulation Compensates for different baking conditions and loads. <ul style="list-style-type: none"> • Partial loads • Baking temperatures • Baking chamber door opening times • Product temperature • Fluctuations in the power supply The baking program must be saved once.
	Display	List of possible baking phases.
	Button	Touching a digit activates the DUPLICATE and DELETE buttons.
	PASTE button Baking phase selected New baking phase is inserted after the selected phase No baking phase selected New baking phase is inserted at the end	
	DUPLICATE button Select baking phase and touch button. Duplicate baking phase is inserted after the selected phase. There is no prompt.	
	DELETE button Select baking phase and touch button. There is no prompt.	

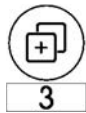
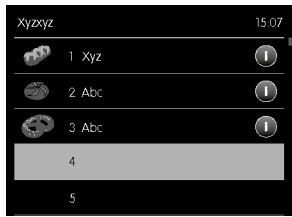
Display Button	Explanation
	Total baking time in minutes and seconds.
	HELP button Opens a menu with additional information.
	Confirms values entered and returns to the MANAGE PROGRAMS menu.
	Discards changes and returns to previous menu

8.9.2. Copying and pasting baking programs

A baking program can be copied and pasted to a new position in the list so that it can then be changed and saved under a new name.



1. Touch the PROGRAMS button in the MAIN MENU. The MANAGE PROGRAMS menu will open.
2. Select a baking program. Touch the memory location of the baking program in the list.
3. Touch the COPY button. The baking program previously selected will be copied to the clipboard.



3

4. Touch a free memory location.
5. Touch the PASTE button.
The prompt 'Do you really want to overwrite this program?' will appear.



Cancels action.



The baking program is copied to the selected memory location.

8.9.3. Deleting baking programs

Baking programs which are no longer needed can be deleted from the list.



1. Touch the PROGRAMS button in the MAIN MENU.
The MANAGE PROGRAMS menu will open.
2. Select a baking program.
Touch the memory location of the baking program in the list.
3. Touch the DELETE button.
The prompt 'Do you really want to delete this program?' will appear.

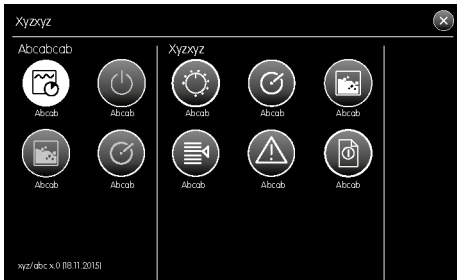


Cancels action.



Deletes program.

8.10. Cleaning programs



1. Touch the MAIN MENU button.
The MAIN MENU will open.

2. Touch the CLEAN button in the OPERATING MODES section.
The CLEANING PROGRAMS menu will open.

Further information



1. Touch the HELP button.
A menu with additional information will open.



NOTE!

For further information on using the cleaning programs, please see 'Cleaning programs' in 'Cleaning and care'.

9. Faults

This section sets out possible causes of faults and fault clearance options.

If faults occur with increasing frequency, shorten the maintenance intervals in line with actual use.

9.1. Safety information



RISK OF ELECTROCUTION!

Contact with live parts can kill. Damage to the insulation or individual components can cause death.

- Always have work on electrical equipment carried out by qualified electricians.
- Before any work, switch off the power supply to the unit and make sure it cannot be switched back on, and check that no parts are live.
- Protect live parts from moisture.
Moisture can cause electric shocks and short-circuiting.
- Have damaged insulation repaired.
- Never bypass or disable safety devices such as fuses or safety thermostats.
- Observe the correct amperage and characteristics when replacing fuses.
- If the unit is to be disconnected from the power supply, unplug the connector.



HOT SURFACES CAN CAUSE INJURY!

Touching hot surfaces can result in serious injury.

- Allow the unit to cool down to ambient temperature.
- Wear the prescribed protective clothing for all work.



RISK OF FALLING!

A fall from a unit can cause serious injury.

In accordance with health and safety regulations, anyone working at a height of 1.50 m or more must use the appropriate, approved equipment.

- Sturdy ladder
- Scaffolding
- Lifting platform

The owner-operator must provide this equipment and comply with official industry association health and safety regulations.

**CAUTION: INCORRECT FAULT CLEARANCE CAN CAUSE INJURY!**

Incorrect fault clearance can result in serious injury and damage.

- Before any work, switch off the power supply to the unit and make sure it cannot be switched back on, and check that no parts are live.
- Allow the unit to cool down to ambient temperature.
- Before starting any work, make sure there is sufficient space for installation and assembly.
- Make sure the work area is sufficiently well lit.
- Make sure that the work area is clean and tidy.
Loosely piling components and tools or leaving them lying around can cause accidents.
- Ensure correct assembly/installation.
Refit all fastening elements and apply the correct screw tightening torques.
- Close off the workspace to unauthorised persons.

Personnel

- The work described here for fault clearance can be carried out by the operator unless otherwise indicated.
- Certain jobs may only be carried out by specially trained qualified personnel or only by the manufacturer. This is indicated in the description of the faults in question.
- Always have work on electrical equipment carried out by qualified electricians.

Qualified electrician

A qualified electrician has the technical training, expertise and experience necessary to assess and carry out all electrical work assigned to them and to recognise potential hazards.

The above person(s) must be familiar with/able to:

- Install low-voltage systems.
- Operate electrical systems.
- Machine safety.
- Electrical safety devices.
- Human-machine interfaces.
- Install stationary electrical facilities.
- Lay and connect electrical lines and connections.
- Fit distributors, residual current devices, switches, push buttons and sockets.
- Measure the effectiveness of electrical safety devices.



IMPORTANT NOTE ON ELECTRICAL SYSTEMS IN GERMANY

The qualified electrician must be registered in the network operator's register of installation engineers [*Installateurverzeichnis*]. Qualified electricians receive training on the latest standards, legislation and technical developments at least once a year.

Qualified electricians have a duty to observe the following national and regional laws and regulations:

- Accident prevention regulations - for Germany, DGUV Vorschrift 3 (previously BGV A3)

9.2. What to do in the event of a fault



1. Identify possible cause.
2. If clearing the fault requires work in the hazard zone, switch off the power supply to the unit and make sure it cannot be switched back on, and check that no parts are live.
3. Inform the competent person at the site about the fault.
4. Arrange for MIWE service to deal with the fault or deal with it yourself as appropriate.



NOTE!

If the fault continues, contact MIWE service.

9.3. Electrical and mechanical faults

Possible cause	Fault clearance
Unit power off upon start-up	
Power supply interrupted.	<p>By owner-operator</p> <ul style="list-style-type: none"> • Actuate the safety temperature limiter (see 'Actuating the safety temperature limiter').

Unit cannot be switched on	
Power supply interrupted during operation.	<p>By owner-operator</p> <ul style="list-style-type: none"> • Check that the unit is properly connected to the power supply (visual check). • Switch the unit back on.
<p>The safety temperature limiter has tripped.</p> <ul style="list-style-type: none"> • Heating OFF. • Operating unit ON. 	<p>By owner-operator</p> <ul style="list-style-type: none"> • Actuate the safety temperature limiter (see 'Actuating the safety temperature limiter').
ON / OFF key defective.	By MIWE service
Circulating fan does not start up within 15 seconds of baking chamber door being closed	
The thermal protection switch in the circulating motor has cut out.	<p>Automatic</p> <ul style="list-style-type: none"> • Thermal protection switch closes automatically once the overheated circulating motors have cooled down.
Operating unit, circulating motor or contactor is defective.	By MIWE service
DOOR OPEN symbol lit up.	<p>By owner-operator</p> <ul style="list-style-type: none"> • Open and close the baking chamber door.
Baking chamber lighting is not working	
Lamp is defective.	By MIWE service
Uneven results	
Heating defective.	By MIWE service

Steam input is not working / not working properly

Water supply line faulty.	<p>By owner-operator</p> <ul style="list-style-type: none"> • Check water supply line for leaks.
Water supply line closed.	<p>By owner-operator</p> <ul style="list-style-type: none"> • Open the water supply line.
Fine filter in connection piece dirty.	<p>By owner-operator</p> <ul style="list-style-type: none"> • Clean the fine filter in the connection piece (see 'Inspection and maintenance', 'Cleaning the filter in the water system connection piece').
Water supply too low.	<p>By MIWE service</p>
Solenoid valve defective.	<p>By MIWE service</p>
Steam device dirty / scaled up.	<p>By MIWE service</p>

Baking chamber door hard to close

<p>Model with side-hinged door Baking chamber door catch not aligned.</p>	<p>By owner-operator</p> <ul style="list-style-type: none"> • Adjust baking chamber door catch (see 'Inspection and maintenance', 'Setting the baking chamber door pin and catch').
--	---

Baking chamber door will not open or does not open at end of baking

<p>Model with side-hinged door Door catch defective.</p>	<p>By owner-operator</p> <ul style="list-style-type: none"> • Open the baking chamber door using the emergency release function (see 'Opening the baking chamber door with the emergency release function'). <p>By MIWE service</p> <ul style="list-style-type: none"> • Repair the door catch.
---	---

MIWE easy clean not working

Water supply line faulty.

By owner-operator

- Check water supply line for leaks.

Water supply line closed.

By owner-operator

- Open the water supply line.

Cleaning with MIWE cleaning control (optional) has not produced satisfactory results

Cleaning cycle has run without cleaning agent.

By owner-operator

- Top up cleaning agent.

Water supply line closed.

By owner-operator

- Open the water supply line.

Water pressure too low.

By owner-operator

- Check that the water pressure is at least 2 bar.

Spray nozzle dirty.
Spray nozzle will not rotate or jams.**By owner-operator**

- Check spray nozzle (see 'Checking the spray nozzle is functioning correctly')

Spray nozzle scaled up.

By owner-operator

- Check spray nozzle (see 'Checking the spray nozzle is functioning correctly')
- Check water filter (optional).
Replace if necessary.

Water filter needs replacing.

By owner-operator

- Change the water filter.

Cleaning agent is washed into the baking chamber when cleaning is not in progress

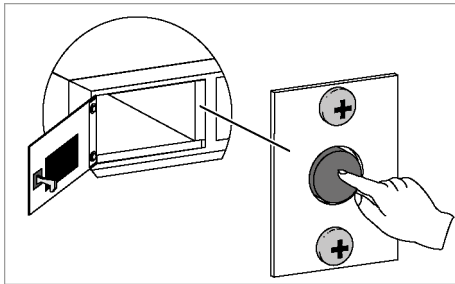
Relay defective.

By MIWE service

By owner-operator

- Dispose of products (safety).

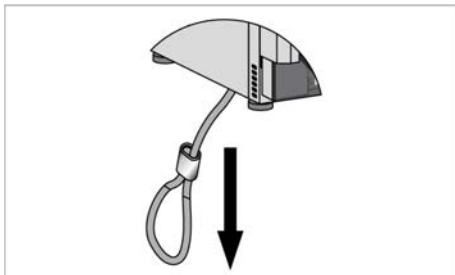
9.3.1. Actuating the safety temperature limiter



1. Press the safety temperature limiter a maximum of twice.
If the fault continues, contact MIWE service.

9.3.2. Opening the baking chamber with the emergency release function

If a mechanical fault means the baking chamber door cannot be opened, it will in an emergency have to be released manually.



1. Pull the cable by the loop.

10. Cleaning and care

10.1. Safety information

For hygiene and health reasons, the unit must be carefully cleaned every day.



RISK OF ELECTROCUTION!

Contact with live parts can kill. Damage to the insulation or individual components can cause death.

- Always have work on electrical equipment carried out by qualified electricians.
- Before any work, switch off the power supply to the unit and make sure it cannot be switched back on, and check that no parts are live.
- Protect live parts from moisture.
Moisture can cause electric shocks and short-circuiting.
- Have damaged insulation repaired.
- Never bypass or disable safety devices such as fuses or safety thermostats.
- Observe the correct amperage and characteristics when replacing fuses.
- If the unit is to be disconnected from the power supply, unplug the connector.



HOT SURFACES CAN CAUSE INJURY!

Touching hot surfaces can result in serious injury.

- Allow the unit to cool down to ambient temperature.
- Wear the prescribed protective clothing for all work.



RISK OF FALLING!

A fall from a unit can cause serious injury.

In accordance with health and safety regulations, anyone working at a height of 1.50 m or more must use the appropriate, approved equipment.

- Sturdy ladder
- Scaffolding
- Lifting platform

The owner-operator must provide this equipment and comply with official industry association health and safety regulations.



CAUTION: EDGES AND CORNERS CAN CAUSE INJURY!

Sharp edges and corners can cause cuts and grazes.

- Always be careful when working at components with sharp edges or corners.
- Wear the prescribed protective clothing for all work.

10.2. Cleaning schedule

Cleaning	Section in documentation	Intervals (1-shift operation)	Intervals (3-shift operation)
Housing	x	Daily	Daily
Operating unit			
Baking chamber			
Glass panel			
Door seal			
Tray supports			
Baking trays			
Container for waste water			
Vents			
Baking chamber with MIWE cleaning control cleaning program			

10.3. Cleaning



CAUTION: INCORRECT CLEANING CAN CAUSE DAMAGE!

Cleaning the unit incorrectly can damage it.

- Never clean the unit with a pressure hose.
- Do not use abrasive cleaning agents or scourers.
- Never use steel wool or any other sharp-edged cleaning materials.
- Only ever clean the unit with a soft, slightly damp cloth.
- Follow the specific instructions of the manufacturer for all cleaning agents and equipment.



CAUTION: DIRTY SERVICE FLUIDS AND EQUIPMENT ARE A HEALTH RISK!

Areas that come into direct contact with food are subject to strict hygiene requirements. Dirty service fluids or equipment encourage the growth and development of harmful microorganisms. Inhaling and digesting these organisms can be injurious to health.

- Use separate, clean service fluids and equipment for food systems.

10.3.1. Casing



1. Switch off the power supply to the unit, make sure it cannot be switched back on and check that no parts are live.
Allow the unit to cool down to ambient temperature.
2. Wear the prescribed protective clothing for all work.
3. Clean the casing as required with a soft, slightly damp cloth. If extremely dirty, also use a non-abrasive, sand-free cleaning agent.
Rinse thoroughly after cleaning to ensure no cleaning agent residue remains.

10.3.2. Operating unit



CAUTION: CLEANING AGENT CAN CAUSE DAMAGE!

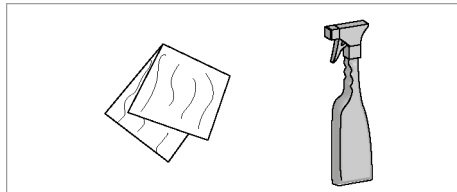
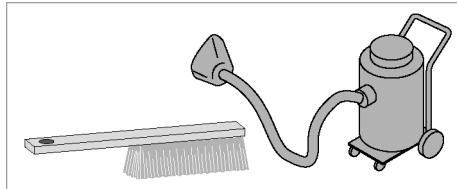
Cleaning agent can damage the operating unit.

- Only ever clean with water.



1. Switch off the power supply to the unit, make sure it cannot be switched back on and check that no parts are live.
Allow the unit to cool down to ambient temperature.
2. Wear the prescribed protective clothing for all work.
3. Clean the operating unit as required with a soft, slightly damp cloth.

10.3.3. Baking chamber



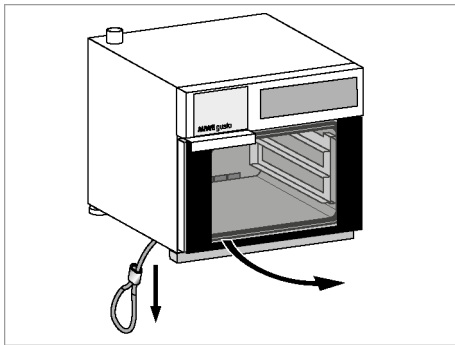
1. Switch off the power supply to the unit, make sure it cannot be switched back on and check that no parts are live.
Allow the unit to cool down to ambient temperature.
2. Wear the prescribed protective clothing for all work.
3. Remove crumbs etc. from the baking chamber using a suitable brush or a vacuum cleaner.
4. Clean the baking chamber as required with a soft, slightly damp cloth. If extremely dirty, also use a non-abrasive, sand-free cleaning agent. Rinse thoroughly after cleaning to ensure no cleaning agent residue remains.

10.3.4. Glass panel

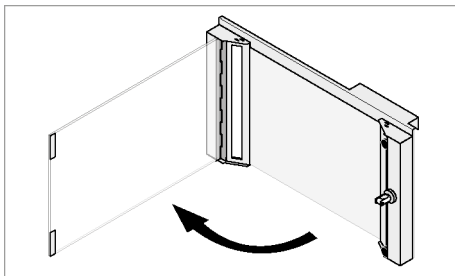


1. Switch off the power supply to the unit, make sure it cannot be switched back on and check that no parts are live.
Allow the unit to cool down to ambient temperature.
2. Wear the prescribed protective clothing for all work.

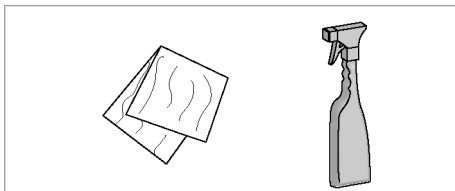
Model with side-hinged door



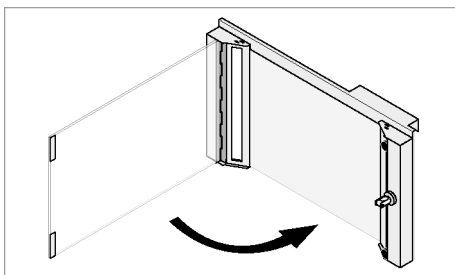
3. Open the baking chamber door.



4. Open inside glass panel into the baking chamber



5. Clean the glass panels as required with a soft, slightly damp cloth. If extremely dirty, also use a non-abrasive, sand-free cleaning agent. Rinse thoroughly after cleaning to ensure no cleaning agent residue remains.



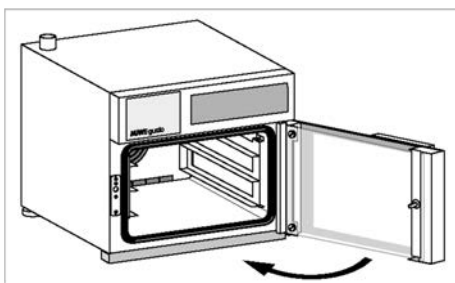
6. Close inside panel carefully. The magnets pose a crush hazard when the glass panels are being closed.



CAUTION: INSIDE PANEL MAY BREAK!

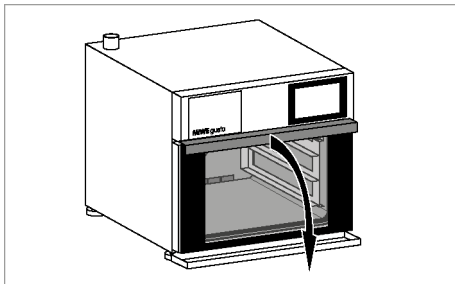
The inside glass panel can be irreparably damaged when the baking chamber door is closed.

- Close the inside panel before closing the baking chamber door.

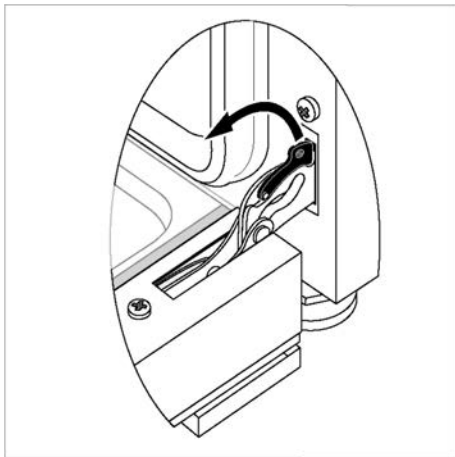


7. Close the baking chamber door.

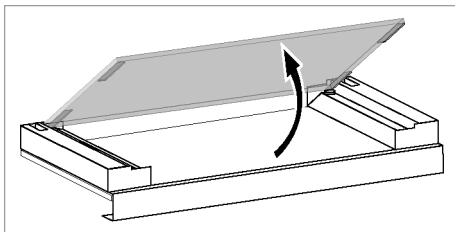
Model with bottom-hinged door



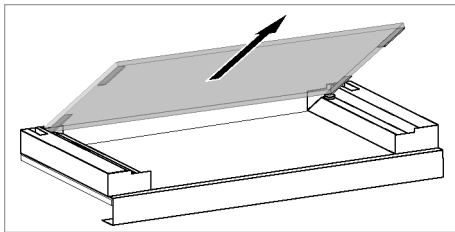
3. Open the baking chamber door.



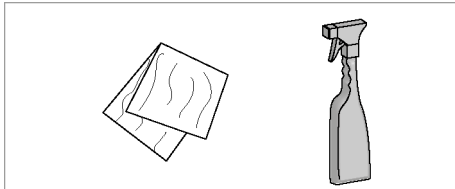
4. Lift up the lever on the hinge.



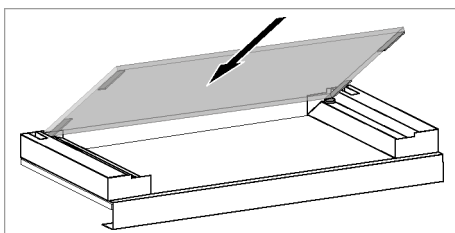
5. Lift up the front edge of the inside glass panel and lift up the panel.



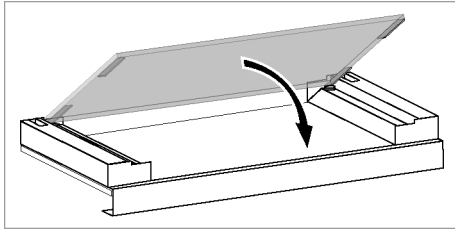
6. Remove inside panel



7. Clean the glass panels as required with a soft, slightly damp cloth. If extremely dirty, also use a non-abrasive, sand-free cleaning agent. Rinse thoroughly after cleaning to ensure no cleaning agent residue remains.



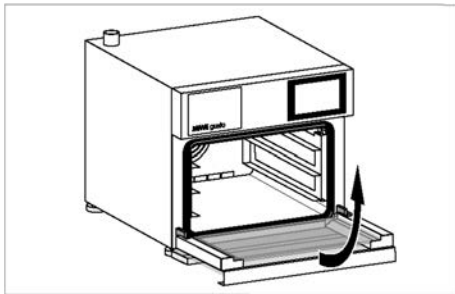
8. Put back edge of inside glass panel in place.



9. Tilt inside glass panel towards you.
The magnets pose a crush hazard when you are inserting the glass panel. Insert panel carefully.

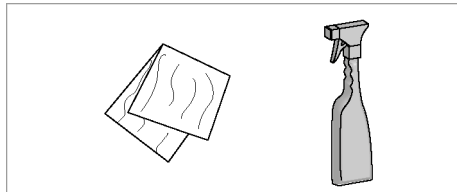


10. Replace lever on the hinge.



11. Close the baking chamber door.

10.3.5. Door seal



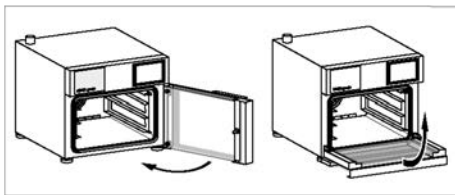
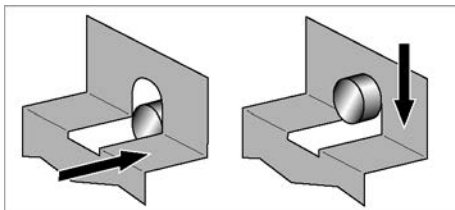
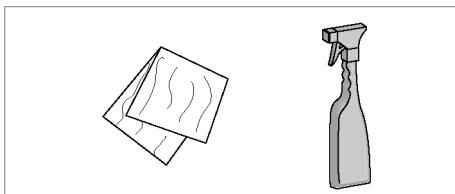
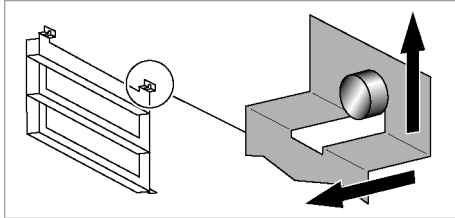
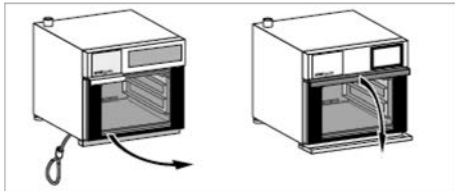
1. Switch off the power supply to the unit, make sure it cannot be switched back on and check that no parts are live.
Allow the unit to cool down to ambient temperature.
2. Wear the prescribed protective clothing for all work.
3. Open the door.
4. Clean the door seal as required with a soft, slightly damp cloth. If extremely dirty, also use a non-abrasive, sand-free cleaning agent.
Rinse thoroughly after cleaning to ensure no cleaning agent residue remains.
5. Close the door.



NOTE!

To prevent premature wear, the manufacturer recommends rubbing the door seal after cleaning with standard, food-safe talcum powder.

10.3.6. Tray supports



1. Switch off the power supply to the unit, make sure it cannot be switched back on and check that no parts are live.
Allow the unit to cool down to ambient temperature.
2. Wear the prescribed protective clothing for all work.
3. Open the baking chamber door.
4. Lift the tray supports up and over the fastening bolts, towards the middle and out.
5. Clean the tray supports as required with a soft, slightly damp cloth. If extremely dirty, also use a non-abrasive, sand-free cleaning agent. Rinse thoroughly after cleaning to ensure no cleaning agent residue remains.
6. Push the tray supports over the fastening bolts and into place.
7. Close the baking chamber door.



NOTE!

You should also clean the tray supports in any optional base units. These tray supports cannot, however, be removed for cleaning.

10.3.7. Baking trays



CAUTION: DAMAGE TO BAKING TRAYS WITH NON-STICK COATING!

Incorrect use can cause damage to the coating.

- Do not use at temperatures in excess of 270 C.
- Avoid flour dust on silicone-coated baking trays.
- Do not use cleaning agents.
- Do not clean in tray washer, dishwasher or by the self-cleaning mode of the oven.



NOTE!

- Immediately replace baking trays with damaged coating.
- Do not use sharp or pointed objects.
- Store baking trays such that they cannot be damaged.
- Clean the non-coated aluminium baking trays following the manufacturer's instructions.

Non-coated	Coated
<ul style="list-style-type: none"> • Prior to the first baking process, clean in soapy water at at least 60 C and dry. Lubricant residues are removed. 	<ul style="list-style-type: none"> • Prior to the first baking process, clean in hot water and dry.
<ul style="list-style-type: none"> • After baking, clean the baking trays as required with a soft, slightly damp cloth. If extremely dirty, also use a non-abrasive, sand-free cleaning agent. • Rinse thoroughly after cleaning to ensure no cleaning agent residue remains. 	<ul style="list-style-type: none"> • After baking, clean the baking trays as required with a soft, slightly damp cloth.
<ul style="list-style-type: none"> • Grease to prevent rusting (except for aluminium trays). 	<ul style="list-style-type: none"> • Do not grease.

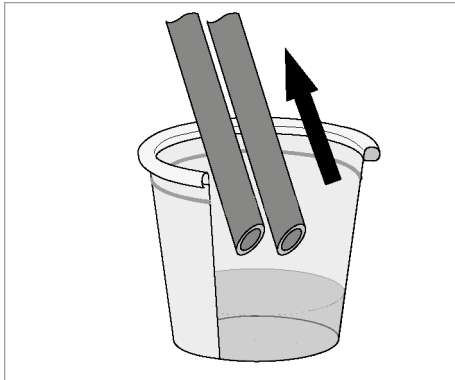
10.3.8. Container for waste water



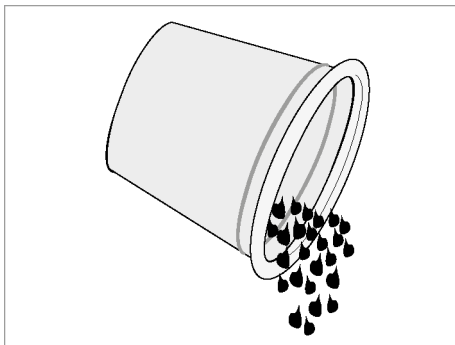
DANGER: HARMFUL MICROORGANISMS

The hot and humid atmosphere encourages the growth and development of harmful microorganisms. Inhaling and ingesting these organisms can damage your health.

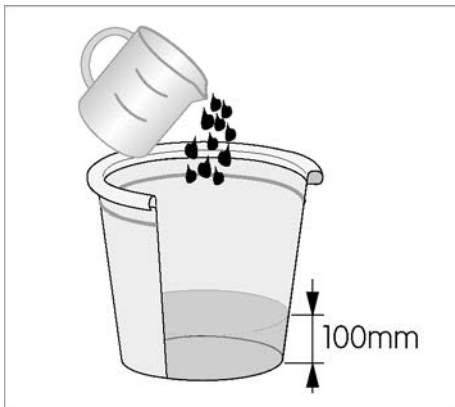
- Empty tanks/containers daily.
- Clean and disinfect tanks/containers with a suitable cleaning agent in accordance with the hygiene regulations.



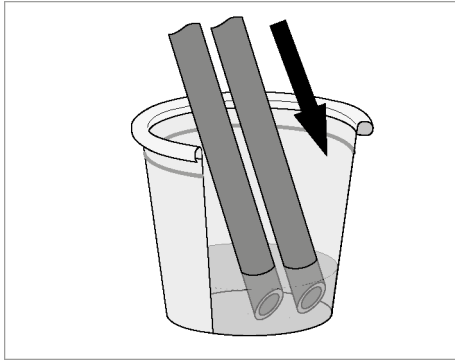
1. Remove drainage hoses from the container.



2. Empty the container.
3. Clean the container.



4. Fill the container with water up to at least 100 mm.



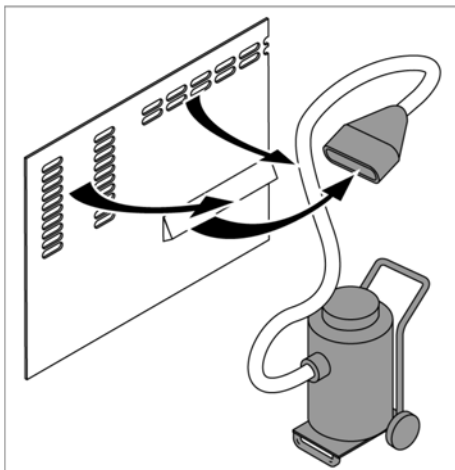
5. Push the drainage hoses down to c. 2 cm from the bottom of the container.

10.3.9. Vents

Dust can collect on the vents.



1. Switch off the power supply to the unit, make sure it cannot be switched back on and check that no parts are live.
Allow the unit to cool down to ambient temperature.
2. Wear the prescribed protective clothing for all work.
3. Only ever vacuum the vents.



10.3.10. Collection channel for baking residue

There is a detachable collection channel below the baking chamber door.

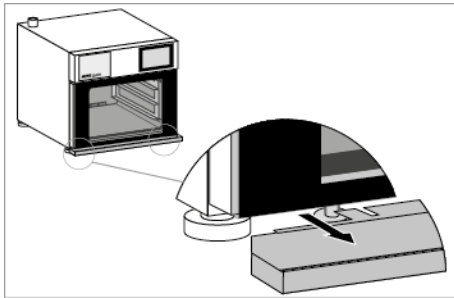


1. Switch off the power supply to the unit, make sure it cannot be switched back on and check that no parts are live.

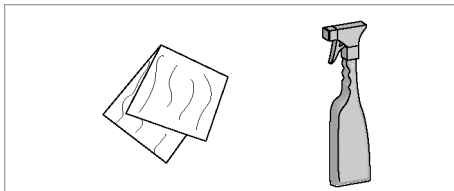
Allow the unit to cool down to ambient temperature.



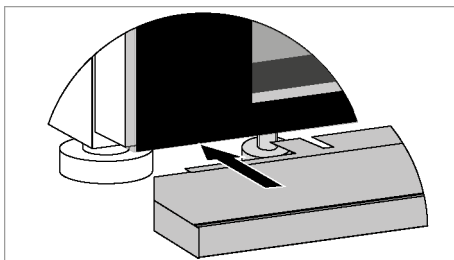
2. Wear the prescribed protective clothing for all work.



3. Pull out the collection channel and remove.



4. Clean the collection channel as required with a soft, slightly damp cloth. If extremely dirty, also use a non-abrasive, sand-free cleaning agent. Rinse thoroughly after cleaning to ensure no cleaning agent residue remains.



5. Push collection channel slotted holes over the screw heads. Push in as far as it will go.

10.4. Cleaning programs for the baking chamber

Please note the following information for the:

- MIWE cleaning control fully automatic cleaning program.
For further information, please see 'MIWE cleaning control cleaning program'.
- MIWE easy clean semi-automatic cleaning program.
For further information, please see 'MIWE easy clean cleaning program'.

The cleaning programs start when the baking chamber door is closed and the water feed line open.

10.4.1. Safety information



WARNING: INCORRECT USE OF THE CLEANING PROGRAM CAN RESULT IN INJURY!

Incorrect use of the cleaning program can result in serious accidents and health risks.

- First allow the oven to cool down completely to ambient temperature.
- Remove the baking trays from the baking chamber before starting the cleaning program.
- Ensure before starting the cleaning program that there are no foreign objects or persons or animals inside the baking chamber.
- Ensure that the unit is not moved whilst the cleaning program is running.

WARNING: INSUFFICIENT WATER FOR THE CLEANING PROGRAM CAN CAUSE DAMAGE!

The cleaning program will not function properly if the water supply line is closed while the cleaning program is running.

- Never cut off the water supply line while the cleaning program is running.



NOTE FOR MULTIPLE BAKING CHAMBERS!

Cleaning is only possible if none of the baking chambers are in use.

10.4.2. Checking the spray nozzle function

Check the spray nozzle is functioning correctly before starting the cleaning program.

The spray nozzle rotor must turn easily.

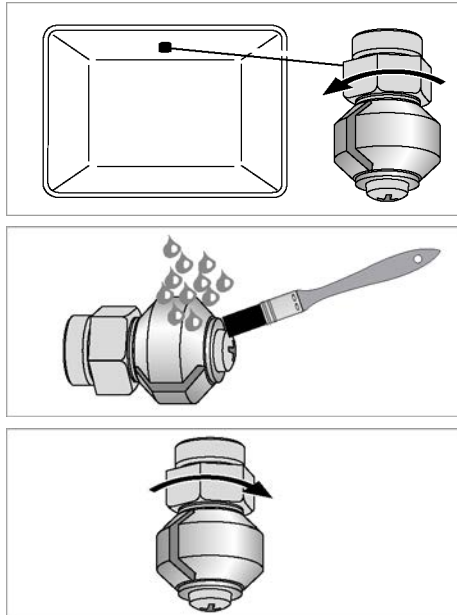
Clean the spray nozzle if this is not the case.



WARNING: USING TOOLS TO SCREW ON THE SPRAY NOZZLE CAN CAUSE DAMAGE!

Tools can damage the spray nozzle and its bracket, rendering it unfit for use.

- Never use tools to screw on the spray nozzle.



1. Unscrew the spray nozzle (anticlockwise).

2. Clean the spray nozzle with a soft brush and running water.

3. Screw on the spray nozzle by hand (clockwise)



NOTE!

The best cleaning results are only achieved with a spray nozzle.

10.4.3. Checking the door seal



WARNING: LEAKING LIQUIDS CAN CAUSE INJURY!

If the door seal is damaged, liquids may leak out during the cleaning process.

- Check the door seal before each cleaning cycle.



1. Check the door seal for damage such as cracks.
2. Remove the worst of the dirt from the door seal.

10.4.4. Check at the end of the cleaning program

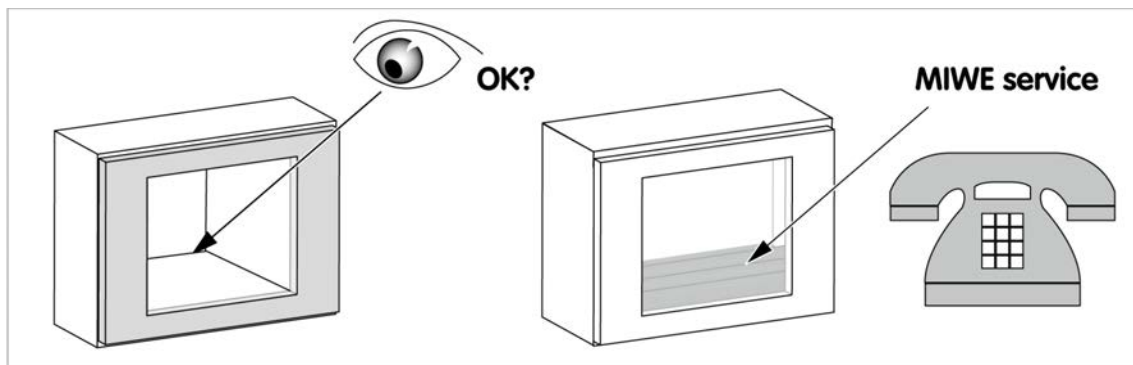


WARNING: LEAKING LIQUIDS CAN CAUSE INJURY AND DAMAGE!

If the baking chamber door is unlocked and opened before all hot liquid has drained from the baking chamber, liquid may escape and cause scalding.

- Visual inspection.

Carry out a visual inspection



1. Look to see whether there is any liquid left in the baking chamber.
2. Do not open the baking chamber door if there is liquid left in the baking chamber. Contact MIWE service.

10.5. MIWE cleaning control cleaning program

MIWE cleaning control is a fully automatic program for cleaning the baking chamber. It does not require any manual operations by the operator.

- The program cleans the baking chamber with liquid cleaner.
- The cleaning program can be started automatically at set times.
- The cleaning program must be operated with a water treatment system.

10.5.1. Safety information



CAUTION: USING THE WRONG CLEANING AGENT CAN CAUSE DAMAGE!

Using a cleaning agent other than that specified by MIWE can cause material damage.

- Only use the specified cleaning agent.



WARNING: OBSERVE THE INFORMATION ON THE SAFETY DATA SHEET!

Access the relevant safety data sheet from the MIWE homepage.

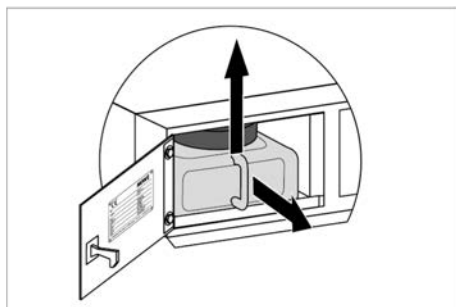
- Go to www.miwe.com / Service / Sicherheitsdatenblätter.
- Enter the item number.
For further information, please see 'Wear and spare parts list'.
- Select country of use.

10.5.2. Filling up the cleaning agent

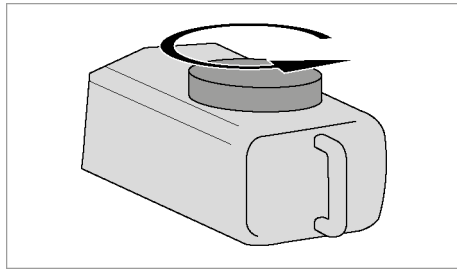
If the cleaner tank is empty, a fault message will appear.



1. Push on the right of the cover panel.
The cover panel will open.



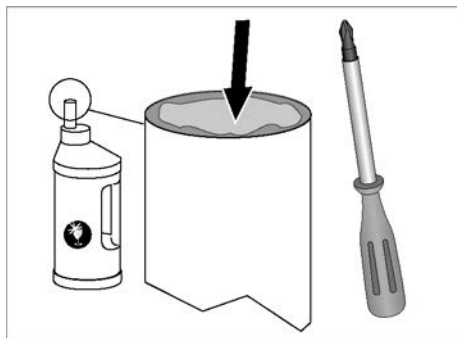
2. Lift the cleaner tank by the handle and pull it out.



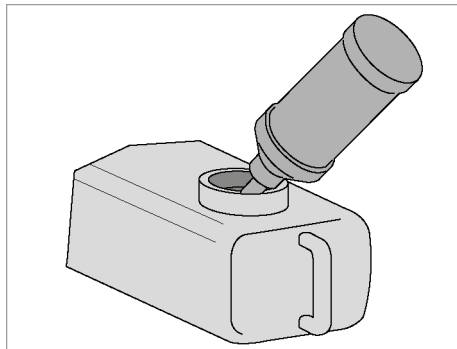
3. Remove the screw top.



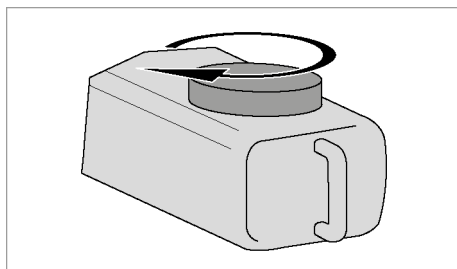
4. Unscrew the protective cap on the bottle of cleaner. The cleaner cannot leak out as there is a film in the neck of the bottle.



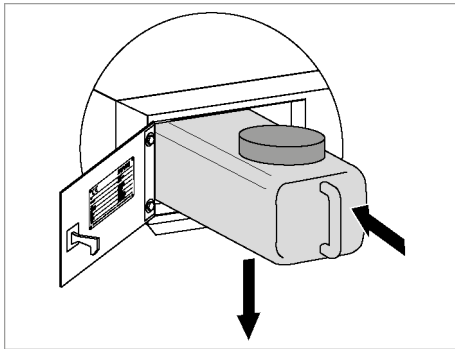
5. With the bottle upright, use a suitable tool to pierce the film.



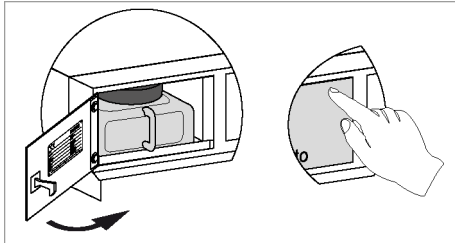
6. Push neck of the bottle right into the filling opening. Empty bottle into the cleaner tank.



7. Replace and close the screw top.



8. Push the cleaner tank in and down.



9. Close the cover panel and push down on the right. This closes the cover panel completely.



10. Screw on the protective cap and dispose of the bottle.

11. Acknowledge the fault message.

10.5.3. Running a cleaning program

Requirement

- The unit is connected to the power supply.
- The oven is in OFF mode.
- Water supply open.

Starting the cleaning program manually



MIWE cleaning-control (xyz)



1. Close the baking chamber door.
2. Touch the MIWE cleaning control (rapid) or MIWE cleaning-control (intensive) button and select the level of dirt
Rapid = slightly dirty
Intensive = extremely dirty
3. Touch the START button.
A prompt will appear.
4. Touch the CONFIRM button.

Cancelling the cleaning program



1. Touch the STOP button.
A prompt will appear.
 2. Touch the CONFIRM button.
- The cleaning program will stop immediately.
 - The cancellation program will start. Duration depends on how far on the cleaning program is.
 - The program rinses out the baking chamber thoroughly with water to remove all residue.



NOTE!

The cleaning program can be cancelled at any time.
This function should, however, only be used when absolutely necessary.

Any phase which has begun will first finish (depends how far the cleaning program is).

Check at end of program

1. Look to see whether there is still any liquid left in the baking chamber.
For further information, please see "Checking the baking chamber at the end of the program".

At the end of the cleaning program:

- The controls switch to OFF mode.
- The controls switch to AUTOSTART if selected.

10.6. MIWE easy clean cleaning program

MIWE easy clean is a semi-automatic cleaning program used to clean the baking chamber.

It requires a number of manual operations by the operator that are indicated by signals sounding.

- Personnel are no longer needed once the drying phase has started.
- The cleaning program consists of a number of different stages. It takes at least 70 minutes and may take longer depending on how dirty the baking chamber is.

10.6.1. Safety information



CAUTION: ESCAPING STEAM/FUMES CAN CAUSE INJURY!

Escaping cleaning agent fumes can cause nausea and headaches.

- Always ensure sufficient ventilation when cleaning with MIWE easy clean.

CAUTION: OVEN AND GRILL CLEANER CAN CAUSE INJURY!

Eye or skin contact with oven or grill cleaner can cause chemical burns and irritation of the skin.

- You must observe the safety information in the manufacturer safety data sheets.
- Wear the prescribed protective clothing for all work.
- Store oven cleaner locked away and out of the reach of children.



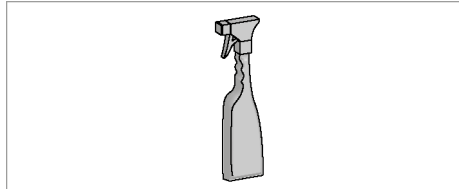
NOTE!

Only use oven cleaner with the following properties:

- food-safe
- alkaline for removing burned-on or encrusted carbohydrates, fats and protein
- intended for use on heated surfaces
- suitable for use on stainless steel, aluminium, glass, silicone, Teflon and graphite seals
- complies with the local laws and health and sewage regulations

10.6.2. Preparing cleaning solution and equipment

Preparing cleaning solution



1. Wear protective goggles and chemical-resistant safety gloves.
2. Fill the spray bottle (capacity of at least 500 ml) with the recommended proportions of cleaner and water.

Slightly dirty	Extremely dirty
1:10	
One part cleaner to ten parts water.	
200 ml cleaning solution per cleaning cycle.	2 x 200 ml cleaning solution per cleaning cycle.

Additional equipment required:

- Spray bottle (capacity of least 500 ml) filled with soft water.
- Commercial glass cleaner
- Bucket
- Soft cloth

10.6.3. Running a cleaning program

Starting a cleaning program



CAUTION: GLASS PANELS MAY BURST AND CAUSE INJURY!

The starting temperature in the baking chamber must be below 180°C. Spraying the glass panel with water may cool it too quickly and cause it to burst.

- Open the baking chamber door and leave the glass panel to cool to ambient temperature on its own.



1. Close the baking chamber door.
2. Touch the MIWE easy clean button.
3. Touch the START button.
A prompt will appear.
4. Touch the CONFIRM button.

Cancelling the cleaning program:

1. Touch the STOP button.
A prompt will appear.
2. Touch the CONFIRM button.

**NOTE!**

The cleaning program can be cancelled at any time.
This function should, however, only be used when absolutely necessary.

Any phase which has begun will first finish (depends how far the cleaning program is).

Check at end of program

1. Look to see whether there is still any liquid left in the baking chamber.
For further information, please see "Checking the baking chamber at the end of the program".

At the end of the cleaning program:

- The controls switch to OFF mode.
- The controls switch to AUTOSTART if selected.

Cleaning phases

The need for manual intervention is indicated as follows:

- A signal sounds
- Information and instructions on the screen

Press the CONTINUE button at the end of a manual operation.

11. Inspection and maintenance

Certain maintenance work must be left strictly to MIWE service or an authorised partner of MIWE service. This is highlighted in the maintenance schedule.

Nevertheless, the owner-operator can help to prevent damage to the unit by carrying out regular visual checks of the relevant components.



WARRANTY

In the interests of machine safety, MIWE requires that only MIWE spare parts be used. The warranty is only valid if original MIWE spares are used.

MIWE spare parts can be obtained from authorised dealers or directly from the manufacturer.

11.1. Safety information



RISK OF ELECTROCUTION!

Contact with live parts can kill. Damage to the insulation or individual components can cause death.

- Always have work on electrical equipment carried out by qualified electricians.
- Before any work, switch off the power supply to the unit and make sure it cannot be switched back on, and check that no parts are live.
- Protect live parts from moisture.
Moisture can cause electric shocks and short-circuiting.
- Have damaged insulation repaired.
- Never bypass or disable safety devices such as fuses or safety thermostats.
- Observe the correct amperage and characteristics when replacing fuses.
- If the unit is to be disconnected from the power supply, unplug the connector.



HOT SURFACES CAN CAUSE INJURY!

Touching hot surfaces can result in serious injury.

- Allow the unit to cool down to ambient temperature.
- Wear the prescribed protective clothing for all work.



INCORRECT MAINTENANCE CAN CAUSE INJURY!

Incorrect maintenance can lead to serious injury and damage.

- Before any work, switch off the power supply to the unit and make sure it cannot be switched back on, and check that no parts are live.
- Before starting any work, make sure there is sufficient space for installation and assembly.
- Make sure the work area is sufficiently well lit.
- Make sure that the work area is clean and tidy.
Loosely piling components and tools or leaving them lying around can cause accidents.
- Ensure correct assembly/installation.
Refit all fastening elements and apply the correct screw tightening torques.
- Close off the workspace to unauthorised persons.

**RISK OF FALLING!**

A fall from a unit can cause serious injury.

In accordance with health and safety regulations, anyone working at a height of 1.50 m or more must use the appropriate, approved equipment.

- Sturdy ladder
- Scaffolding
- Lifting platform

The owner-operator must provide this equipment and comply with official industry association health and safety regulations.

**CAUTION: EDGES AND CORNERS CAN CAUSE INJURY!**

Sharp edges and corners can cause cuts and grazes.

- Always be careful when working at components with sharp edges or corners.
- Wear the prescribed protective clothing for all work.

11.2. Maintenance schedule

The maintenance intervals given here are the minimum frequency required for smooth and satisfactory operation.



MAINTENANCE INSTRUCTIONS

- The owner-operator must ensure daily visual inspections of the unit.
- If there is significant wear, the necessary maintenance intervals must be shortened in accordance with the actual wear.

11.2.1. Maintenance by the owner-operator



CAUTION: DISREGARDING MAINTENANCE INTERVALS CAN LEAD TO DAMAGE!

Disregarding maintenance intervals can lead to damage to the unit and disrupt processes.

- Adhere to the specified maintenance intervals.



SERVICE INFORMATION

To ensure the safety and operation of the product, the manufacturer requires complete servicing by MIWE once a year.

Maintenance work	Section in documentation	Intervals (1-shift operation)	Intervals (3-shift operation)
Check the water treatment system	-	Weekly	Every 4 days
Clean the siphon	x	Monthly	Weekly
Rinse the water drainage hoses			
Check door seal and replace if worn			
Visual inspection of water system; change hoses if worn or leaky	-		
Clean the vapour hood with steam condenser	x	Every 8 weeks	Every 8 weeks
Clean filter in connection piece	x	Once a quarter	Monthly
Change magnets on door frame	x	As required	As required
Model with side-hinged door: Adjust the baking chamber door pin and catch			
Change the cover panel snap fit mechanism			
Clean the steam outlet			
Inspection by MIWE service	-	Every 6–12 months	Every 2–4 months

11.2.2. Maintenance/service by MIWE service

MIWE carries out a range of work as per the inspection plan as part of the annual service. The inspection plan is then completed with the owner-operator and signed by the fitter and the owner-operator. The owner-operator receives a copy of the completed inspection plan.

11.3. Maintenance instructions

These instructions detail all work which can be carried out by the owner-operator's maintenance staff.

Work which may only be carried out by MIWE service is not described in detail.

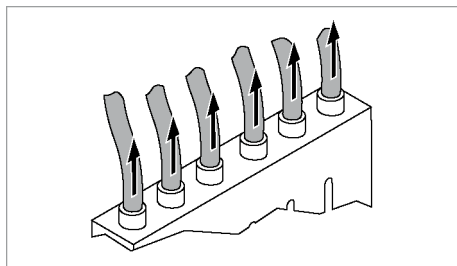
11.3.1. Cleaning the siphon



CAUTION: DIRT CAN CAUSE DAMAGE!

A dirty siphon can cause unit malfunction.

- Clean the siphon in accordance with the maintenance schedule.

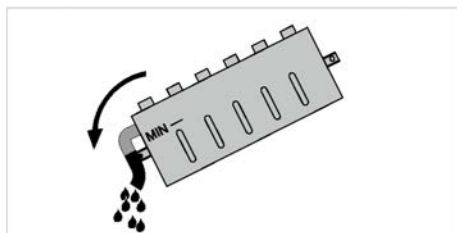


1. Switch off the power supply to the unit, make sure it cannot be switched back on and check that no parts are live. Allow the unit to cool down to ambient temperature.
2. Pull the water drainage hoses up and out of the siphon.

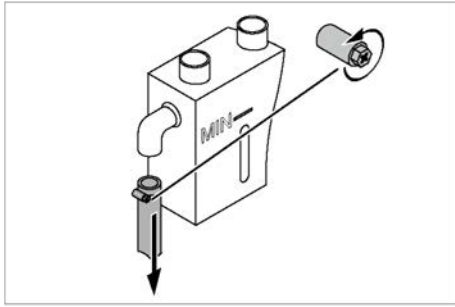


NOTE!

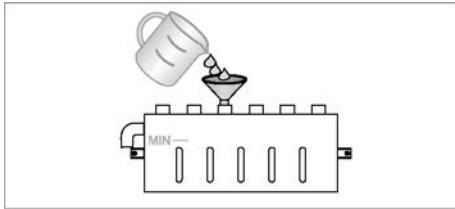
Mark the water drainage hoses to ensure that they are put back in the correct siphon opening afterwards.



3. Remove the siphon from the bracket and tilt to allow the water to drain out through the hose.



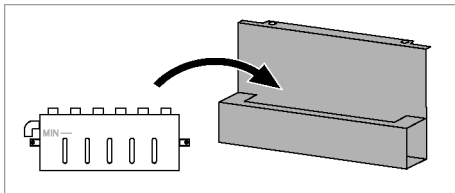
4. Use a suitable tool to loosen the screw in the hose clamp of the water drainage hose, and pull off the hose.



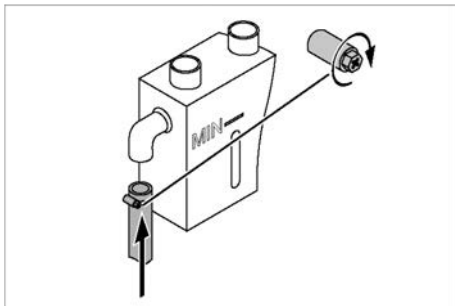
5. Rinse out the siphon:
Use warm water and non-abrasive cleaner.



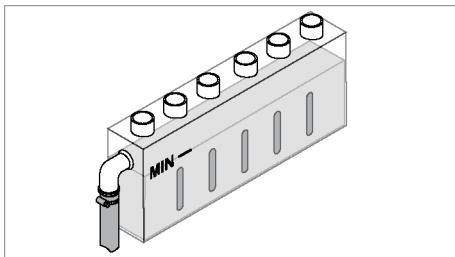
6. Rinsing out the water drainage hose:
For further information, please see 'Rinsing the water drainage hoses'.



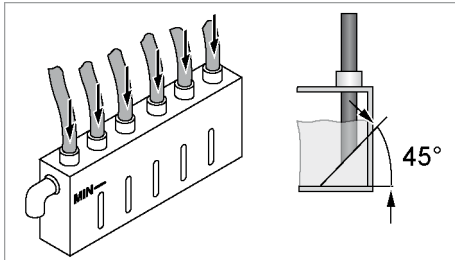
7. Place siphon in siphon bracket.



8. Attach water drainage hose to water drain. Tighten the hose clamp screw with a suitable tool.



9. Fill the siphon with water up to the MIN mark.



10. Push the water drainage hoses (angled) down to c. 2 cm from the bottom of the siphon as marked.

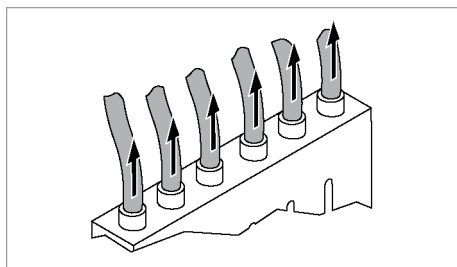
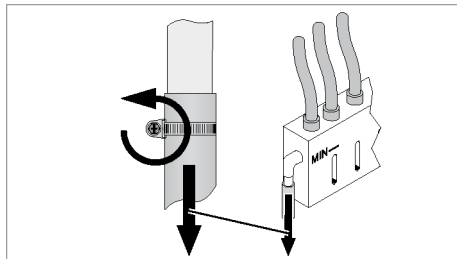


CAUTION: DIRT CAN CAUSE DAMAGE!

If the steam condenser (optional) drainage hoses are in the siphon, they can get dirty over time and affect the flow.

- Make sure when inserting the drainage hoses into the siphon that they are above the water drain.

11.3.2. Rinsing the water drainage hoses

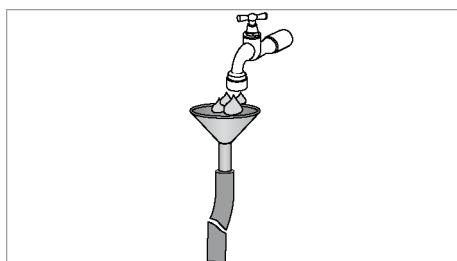
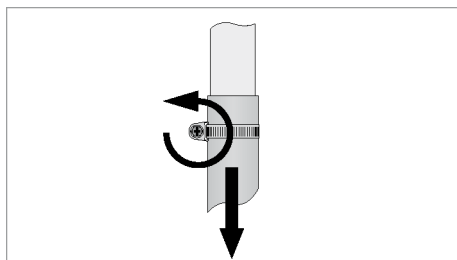


1. Switch off the power supply to the unit, make sure it cannot be switched back on and check that no parts are live.
Allow the unit to cool down to ambient temperature.
2. Remove the water drainage hose from the siphon: Use a suitable tool to loosen the screw in the hose clamp, and pull off the water drainage hose.
3. Pull the water drainage hoses up and out of the siphon.

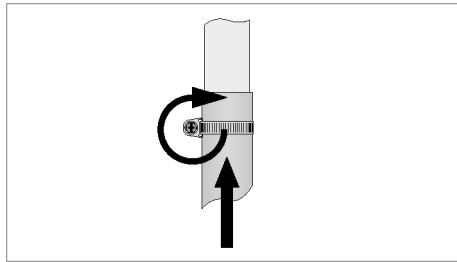


NOTE!

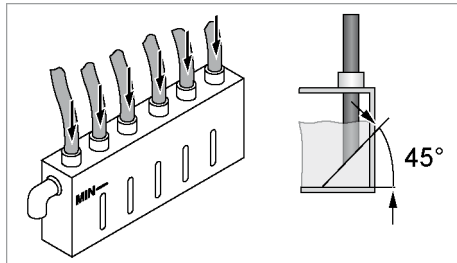
Mark the water drainage hoses to ensure that they are put back in the correct siphon opening afterwards.



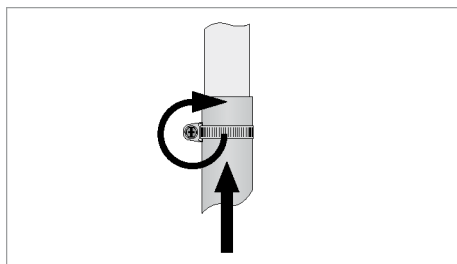
4. Remove the water drainage hoses from the units: Use a suitable tool to loosen the screw in the hose clamp, and pull off the water drainage hose.
5. Rinse out the water drainage hoses: Pour c. 2 litres of warm water into the top of the water drainage hose.



6. Push the water drainage hoses with hose clamp onto the siphon.
Tighten the hose clamp screw with a suitable tool.



7. Push the water drainage hoses (angled) down to c. 2 cm from the bottom of the siphon as marked.



8. Push the water drainage hoses with hose clamps onto the unit condensate outlet.
Tighten the hose clamp screw with a suitable tool.

11.3.3. Changing the door seal

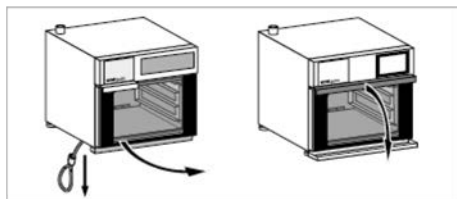
The door seal can become worn over time. Worn seals must be changed immediately.



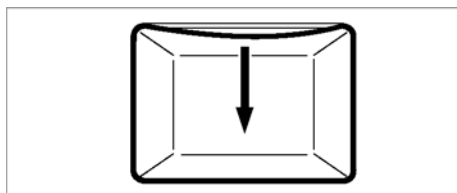
1. Switch off the power supply to the unit, make sure it cannot be switched back on and check that no parts are live.
Allow the unit to cool down to ambient temperature.



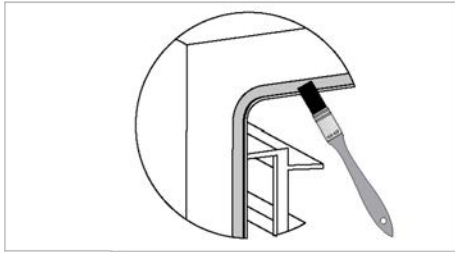
2. Wear the prescribed protective clothing for all work.



3. Open the baking chamber door.



4. Pull the defective door seal out of the seal groove.

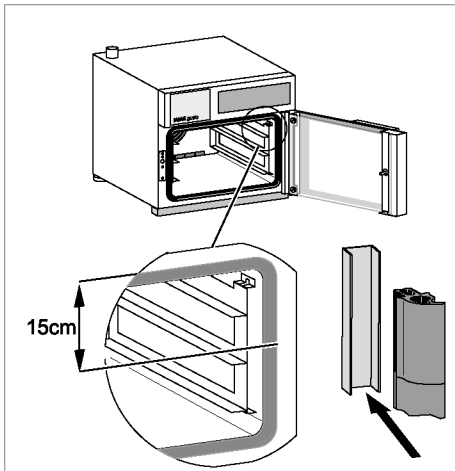


5. Clean the seal groove with a suitable tool.



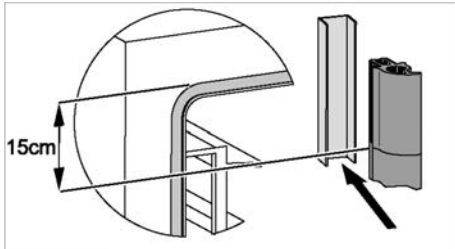
NOTE!

Ensure that the door seal does not get twisted and that it lies flush. Ensure the door seal has no kinks in the corners.



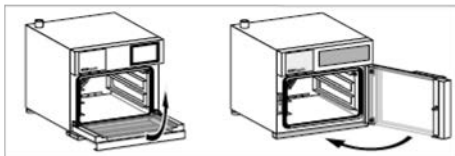
Model with side-hinged door

6. The new door seal should be attached on the hinge side c. 15 cm from the top.
Do not shorten or pull the door seal when inserting it.
Press the door seal into the seal groove.



Model with bottom-hinged door

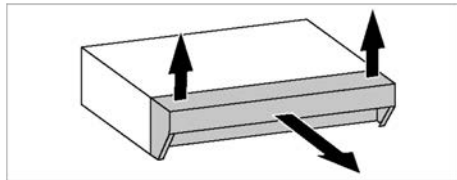
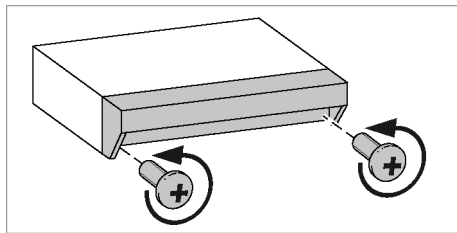
6. The new door seal should be attached at the left c. 15 cm from the top.
Do not shorten or pull the door seal when inserting it.
Press the door seal into the seal groove.



7. Close the baking chamber door.

11.3.4. Cleaning the vapour hood with steam condenser

Removing the vapour hood



1. Switch off the power supply to the unit, make sure it cannot be switched back on and check that no parts are live.
Allow the unit to cool down to ambient temperature.
2. Wear the prescribed protective clothing for all work.
3. Unscrew the screws with a suitable tool.
4. Lift the vapour hood up and out towards you.

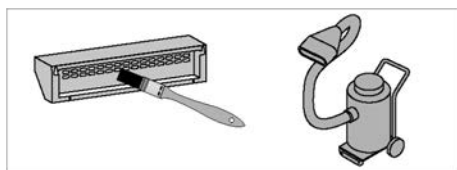


CAUTION: INCORRECT CLEANING CAN CAUSE DAMAGE!

Cleaning the unit incorrectly can damage it.

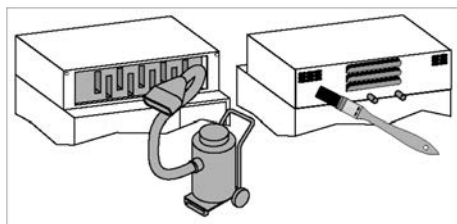
- Do not use compressed air.
- Never clean with a pressure hose.

Cleaning the vapour hood



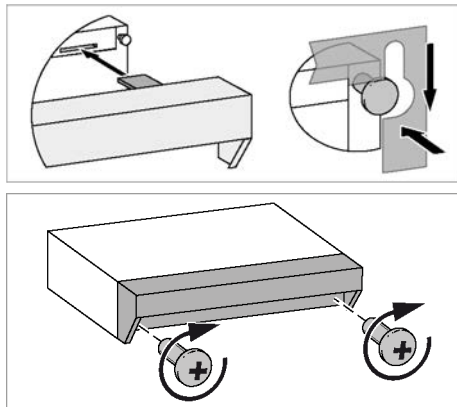
5. Clean the vapour hood with a suitable tool.

Cleaning the steam condenser



1. Clean the cooling fins and vents with a suitable tool.

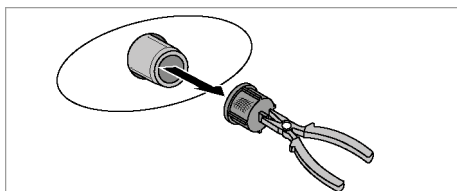
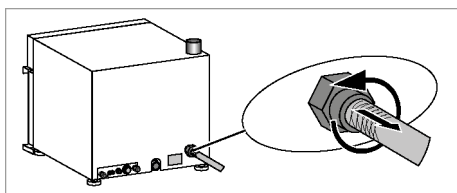
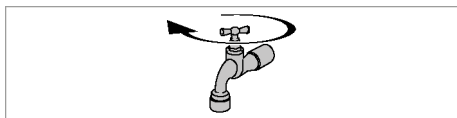
Fitting the vapour hood



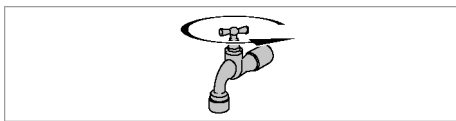
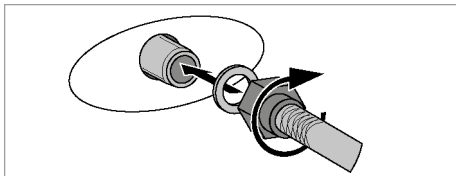
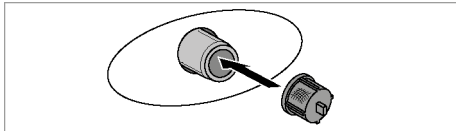
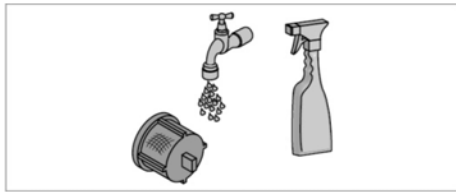
1. Insert both vapour hood tongues into the holes in the unit.
Attach the vapour hood by fitting the keyhole slots on the back over the screws.
2. Screw both screws tight with a suitable tool.

11.3.5. Cleaning the filter in the water system connection piece

The filter prevents foreign particles from getting into the unit through the water supply line. Clean the filter in accordance with the maintenance schedule.



1. Close the shut-off valve in the water supply line.
2. Wait until ready to bake.
Press the STEAM INPUT button to depressurise the water supply line.
3. Switch off the power supply to the unit, make sure it cannot be switched back on and check that no parts are live.
Allow the unit to cool down to ambient temperature.
4. Wear the prescribed protective clothing for all work.
5. Unscrew the union nut from the water supply hose using a suitable tool.
6. Pull out the filter using a suitable tool.



7. Clean the filter with a soft brush under running water.
Use a suitable descaler in case of heavy limescale.
Replace filter if necessary.
8. Insert the filter.
9. Insert new sealing ring in the hose and fasten hose using a suitable tool.
10. Open the shut-off valve in the water supply line.
11. Check water supply line for leaks.
12. Switch ON the power supply and the unit. Heat up the unit. Press the STEAM INPUT button.

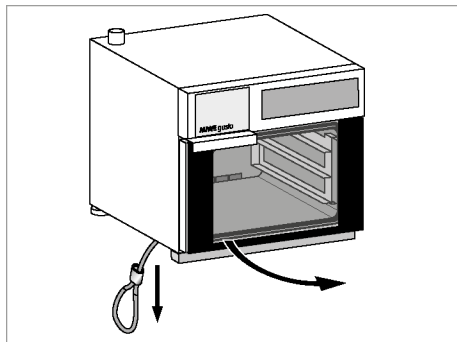
11.3.6. Changing magnets on the door frame

The door frame is fitted with magnets. These can age over time and each will then need to be replaced.

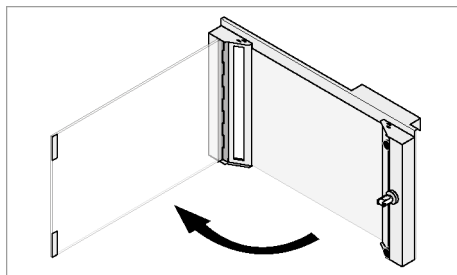


1. Switch off the power supply to the unit, make sure it cannot be switched back on and check that no parts are live.
Allow the unit to cool down to ambient temperature. When closing the doors, ensure you are well away from the opening.
2. Wear the prescribed protective clothing for all work.

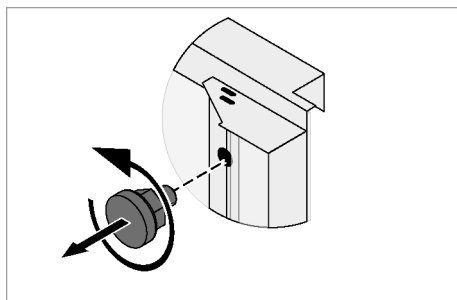
Model with side-hinged door



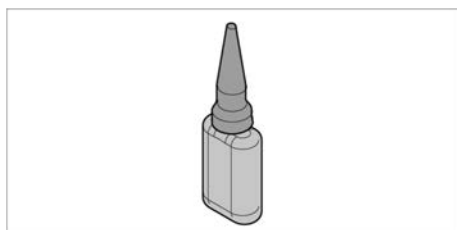
3. Open the baking chamber door.



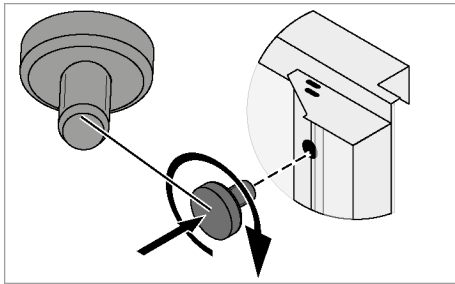
4. Open the inside glass panel into the baking chamber.



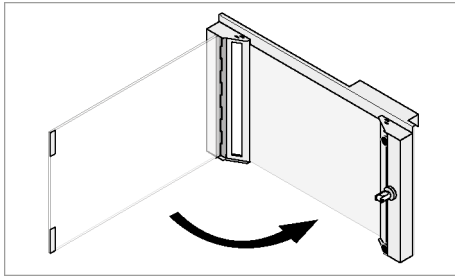
5. Screw the magnet out of the door frame.



6. Coat the thread of the magnet with glue.



7. Screw the new magnet into the door frame.



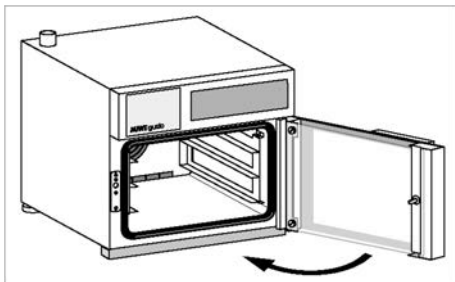
8. Close inside panel carefully.
The magnets pose a crush hazard when the glass panels are being closed.



CAUTION!

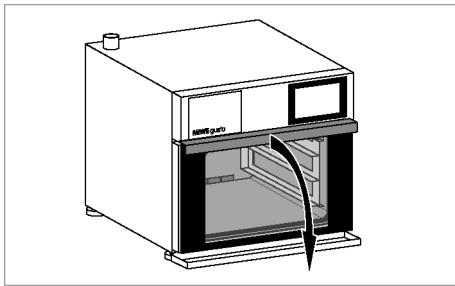
The inside glass panel can be irreparably damaged when the baking chamber door is closed.

- Close the inside panel before closing the baking chamber door.

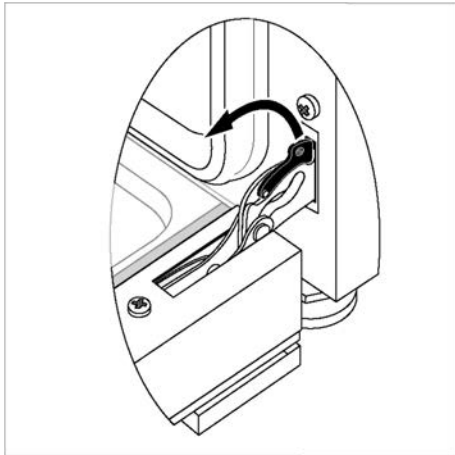


9. Close the baking chamber door.

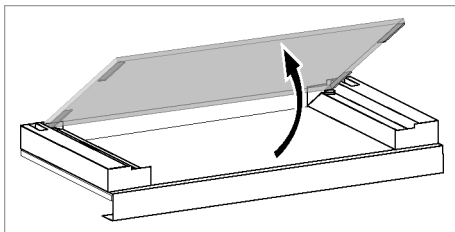
Model with bottom-hinged door



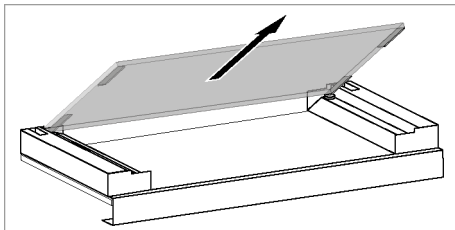
3. Open the baking chamber door.



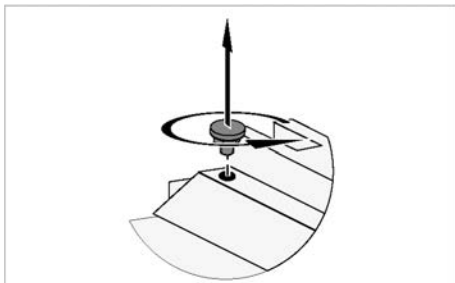
4. Lift up lever on hinge.



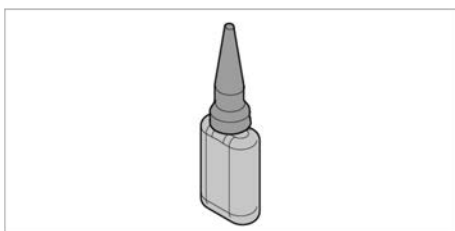
5. Lift up the front edge of the inside glass panel and lift up the panel.



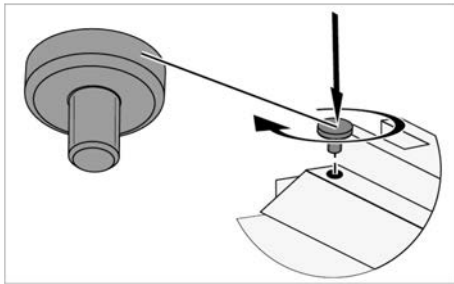
6. Remove inside panel.



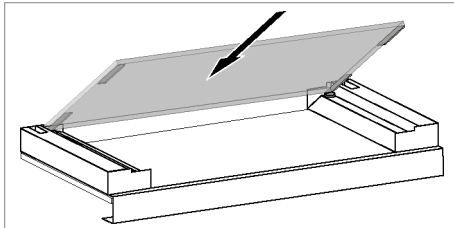
7. Screw the magnet out of the door frame.



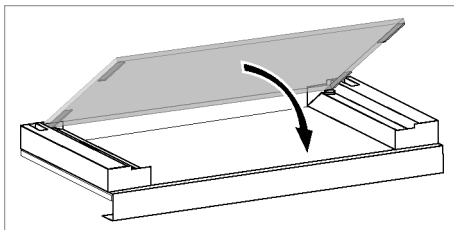
8. Coat the thread of the magnet with glue.



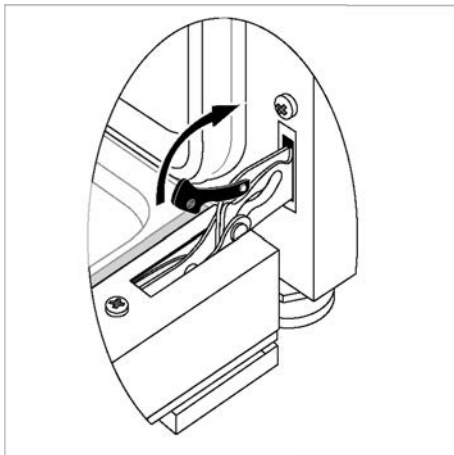
9. Screw the new magnet into the door frame.



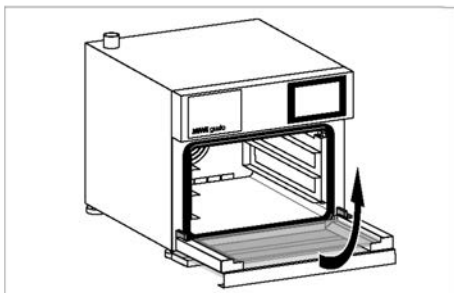
10. Put back edge of inside glass panel in place.



11. Tilt inside glass panel towards you.
The magnets pose a crush hazard when you are inserting the glass panel. Insert panel carefully.



12. Replace lever on the hinge.



13. Close the baking chamber door.

11.3.7. Adjusting the baking chamber door pin and catch

If the baking chamber door is hard to close, the catch and door pin are not exactly aligned.

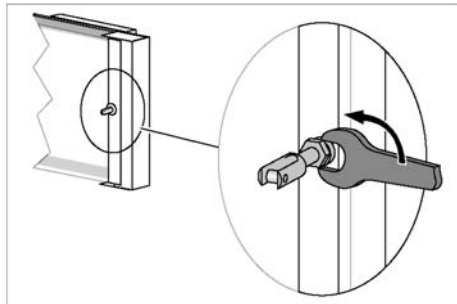
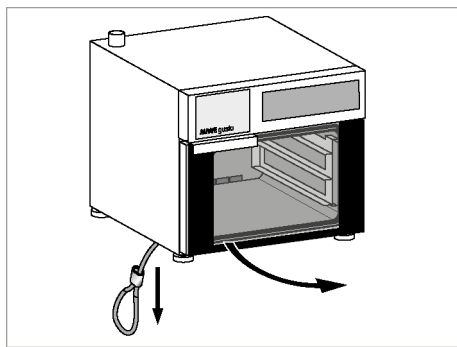


RISK OF INJURY FROM HOT STEAM!

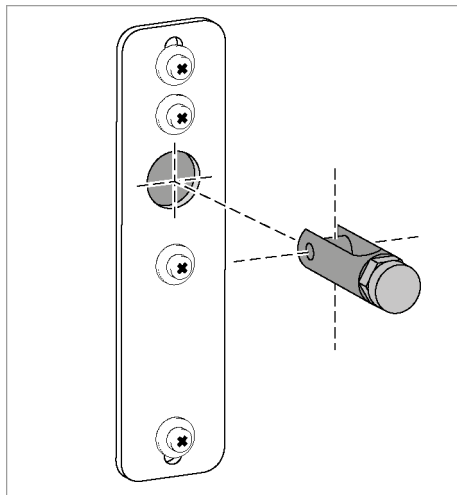
If the door seal is not completely flush with the baking chamber door, hot steam can escape and cause scalding.

- Adjust the door pin and baking chamber door so that the door seal is completely flush.

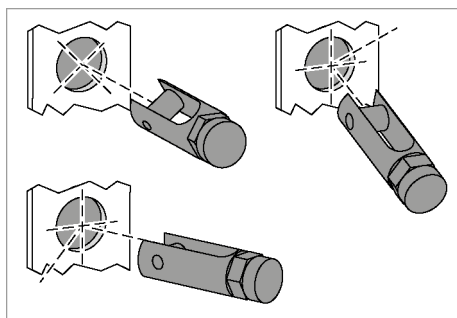
Adjusting the door pin



1. Switch off the power supply to the unit, make sure it cannot be switched back on and check that no parts are live.
Allow the unit to cool down to ambient temperature.
2. Wear the prescribed protective clothing for all work.
3. Open the baking chamber door.
4. Unscrew the retaining nut.

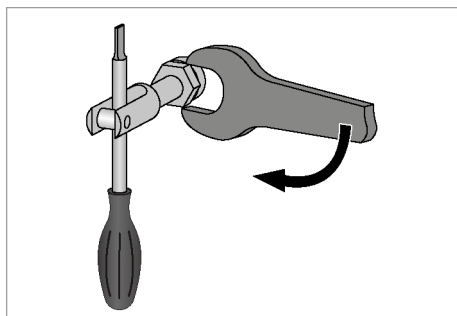


- Adjust the door pin so that it is exactly aligned with the baking chamber door catch.

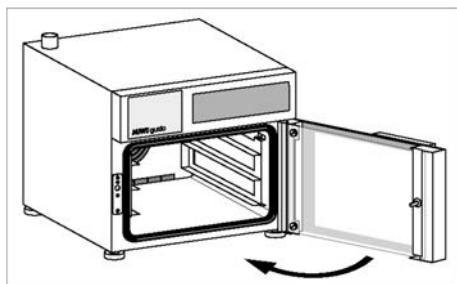


The door pin must not be

- twisted
- pushed down
- pushed up.

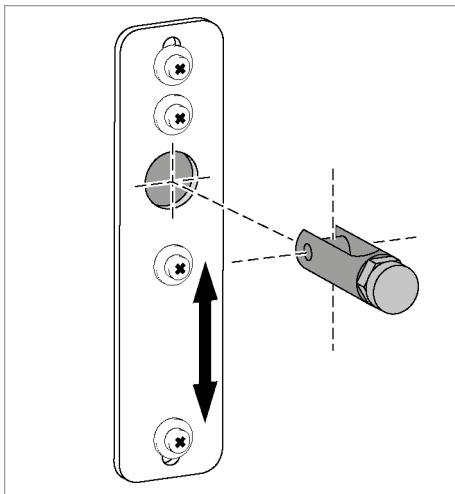
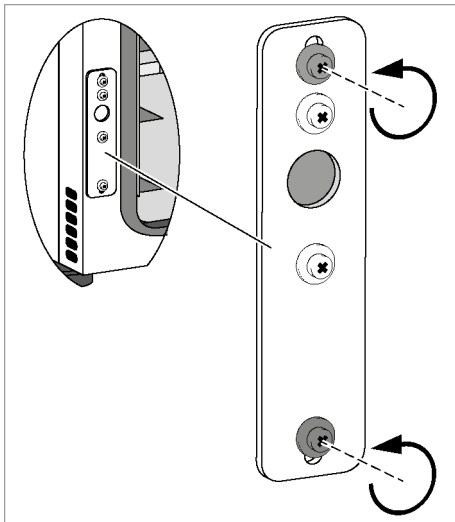
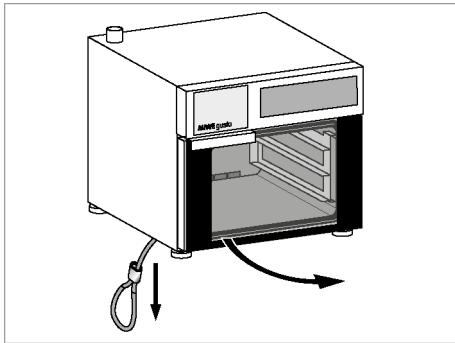


- Secure door pin and retaining nut with a suitable tool.
Tighten the retaining nut.

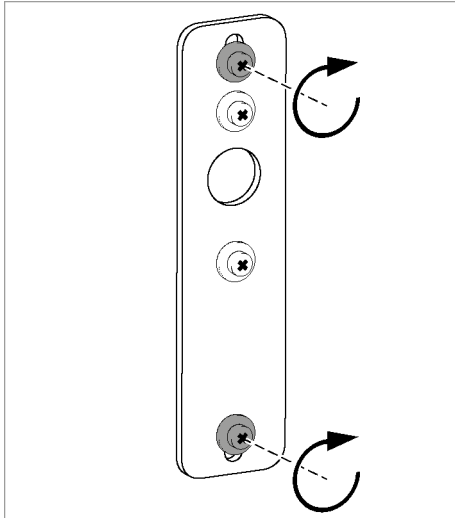


- Close the baking chamber door.

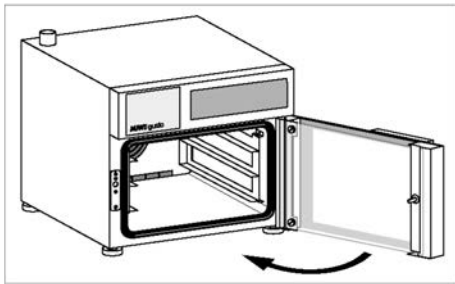
Adjusting the baking chamber door catch



1. Switch off the power supply to the unit, make sure it cannot be switched back on and check that no parts are live.
Allow the unit to cool down to ambient temperature.
2. Wear the prescribed protective clothing for all work.
3. Open the baking chamber door.
4. Unscrew the top and bottom screws in the door catch using a suitable tool.
5. Adjust the retaining plate so that the centre of the hole for the door pin is exactly aligned with the door pin.



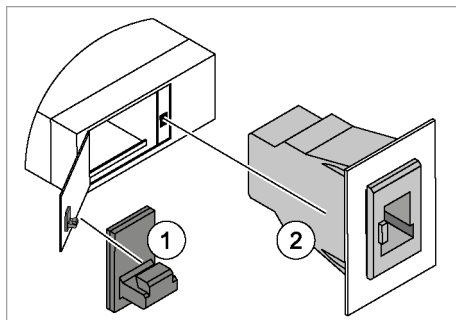
6. Tighten the top and bottom screws in the door catch using a suitable tool.



7. Close the baking chamber door.

11.3.8. Changing the snap fit in the cover panel

If the cover panel stops closing properly, the snap fit mechanism is defective and needs to be changed.



- ① Fastening
- ② Catch



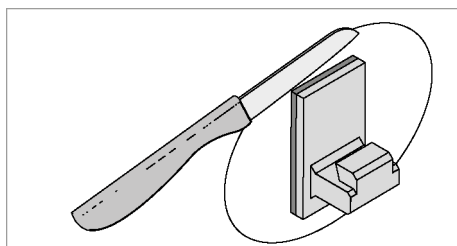
1. Switch off the power supply to the unit, make sure it cannot be switched back on and check that no parts are live.
Allow the unit to cool down to ambient temperature.



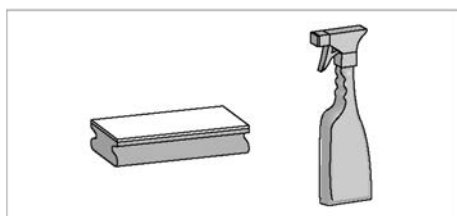
2. Wear the prescribed protective clothing for all work.



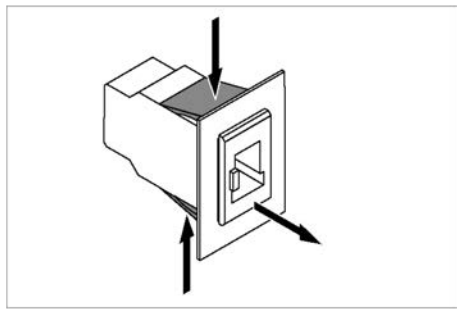
3. Push on the right of the cover panel to open it.



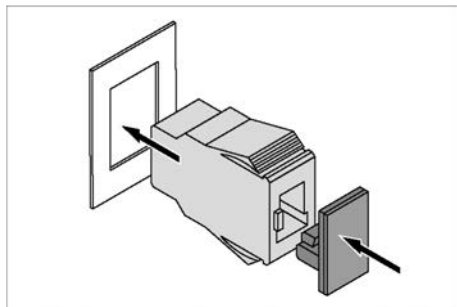
4. Remove the fastening from the cover panel with a suitable tool.



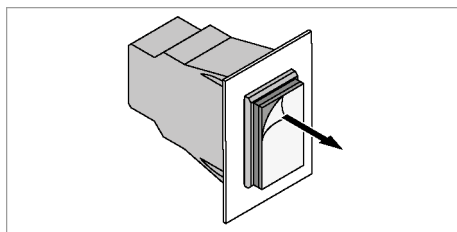
5. Clean the adhesive surface with suitable cleaner. The adhesive surface must be clean and grease-free.



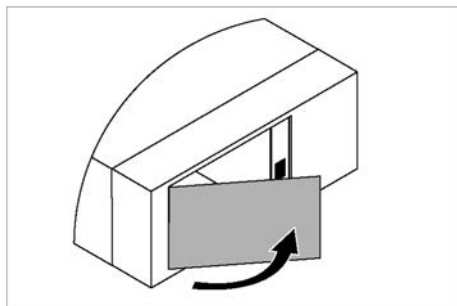
6. Push together the two clips at the sides and remove the catch from out of the front of the frame.



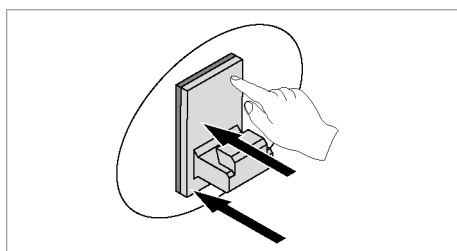
7. Push the new catch with fastening into the frame.
 • The clips at the side must slot into the frame.
 • The fastening is released by pressing it in.
 8. Push the fastening back into the catch.



9. Remove the protective film from the adhesive surface.

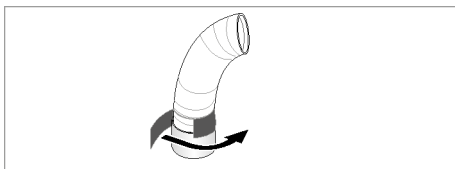
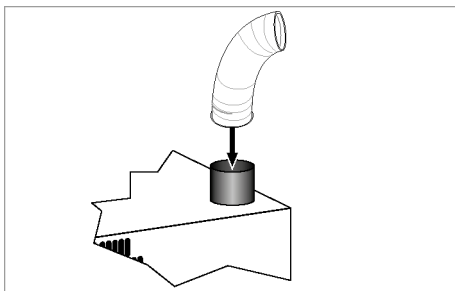
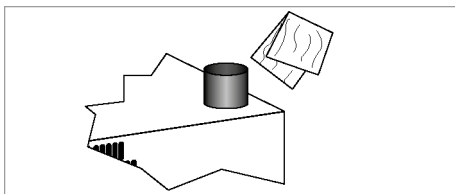
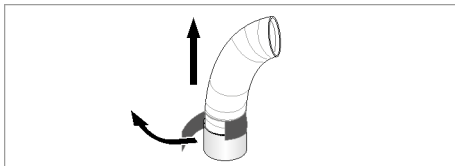


10. Close the cover panel, pressing against the adhesive surface.



11. Open the cover panel and press the fastening against the cover panel.

11.3.9. Cleaning the steam outlet



1. Switch off the power supply to the unit, make sure it cannot be switched back on and check that no parts are live.
Allow the unit to cool down to ambient temperature.
2. Wear the prescribed protective clothing for all work.
3. Remove the adhesive metal tape from the flexible pipe.
Remove the flexible pipe from the steam discharge connection.
4. Clean the inside of the steam discharge connection.
5. Push the flexible pipe into the steam discharge connection from the top.
6. Seal the joint with the flexible pipe with adhesive metal tape.

11.4. Start-up after maintenance



1. Check all electrical connections are correctly fitted and secure.
2. Remove all tools and auxiliary materials from the unit.
3. Remove any foreign objects from the unit.
4. Close all maintenance hatches/openings.
5. Check all screwed connections are securely fitted and tight.
6. Switch ON the power supply.
7. Clear or acknowledge all faults.
8. Open the water feed line
9. Check function by performing a test run.

12. Technical data



NOTE!

The detailed technical data is sent to the owner-operator together with the order confirmation.

12.1. Technical data – product versions

	GU 3.0403
Number of trays	3
Baking tray size in cm	44.5/35
Baking area in m ²	0.47
Airborne sound emissions in dB (A)	< 70

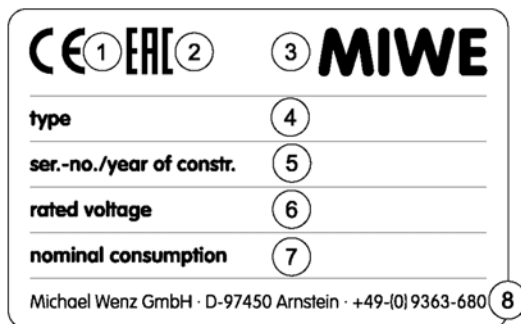


NOTE!

Depending on the place of installation and baking temperature, the surface temperature of the oven can at certain points:

- exceed 65°C on metal surfaces
- exceed 80°C on glass surfaces

12.2. Rating plate



- | | |
|---------------------------------------|---------------------------------------|
| ① EU approval | ⑤ Serial number / year of manufacture |
| ② Approval for European Economic Area | ⑥ Rated voltage |
| ③ Manufacturer logo | ⑦ Rated input |
| ④ Machine type | ⑧ Manufacturer address |

13. Wear and spare parts list

For information on how to replace wear and spare parts, see "Inspection and maintenance".



WARNING: USING THE WRONG SPARE PARTS CAN CAUSE MALFUNCTIONS!

Use of incorrect or defective spare parts can result in damage, malfunctions and even total failure and may also compromise safety, and will render the warranty void.

- Only ever use MIWE spare parts.

Wear part

- Will inevitably become worn during use.
- Must be regularly replaced by the customer or MIWE service in accordance with the maintenance schedule.
- Must be paid for by the customer regardless of any warranty.
- Can be offered by MIWE as a package.

Spare part

- From individual parts to entire modules.
- Free of charge for the customer under the statutory or agreed warranty.
- Must be paid for by the customer if the customer is shown to not have met its maintenance obligations.
- Must be paid for by the customer upon expiry of the warranty.
- Replaced by the customer or only by MIWE service or authorised qualified personnel, depending on the requirements.

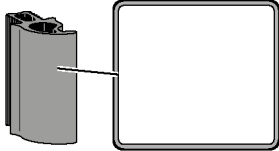
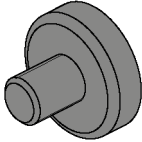
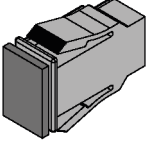
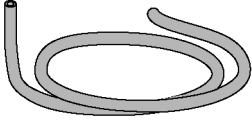
Image	Material number	Designation
	085546.00	Door seal 1525-long
	506949.50	Magnet Ø16 externally threaded pin M6
	505931.05	Southco snap fit
	507422.01	Steam hose (1/2") 13x4.1
	507431.02	Steam hose (3/4")19x4.5 NBR

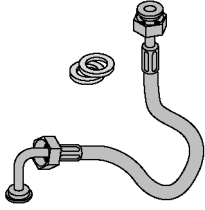
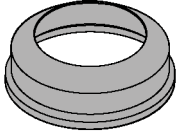
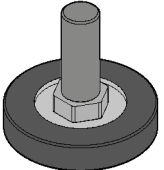
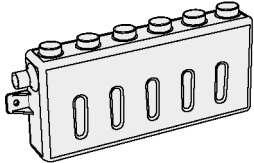
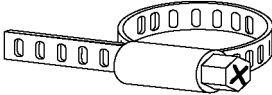
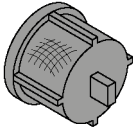
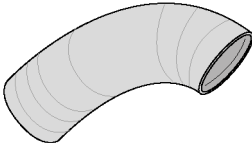

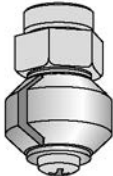
Image	Material number	Designation
	507439.31	Water supply hose, flat sealing, 3/4"x3000
	505520.01	Siphon seal 2"x60
	Front: 506656.08	Adjustable foot, M10x 50 D= 40
	Back: 506656.07	Adjustable foot, M10x 50 D= 40
	071190.04	Discharge siphon
	507430.00	Clamp thread 16-27
	507436.00	Clamp thread 25-40
	505210.01	Plastic filter, type "C"
	506582.04	Flexible aluminium hose D=50
	506597.03	Aluminium tape C350 50 mm
	187777.30	Nozzle, cpl. l=26


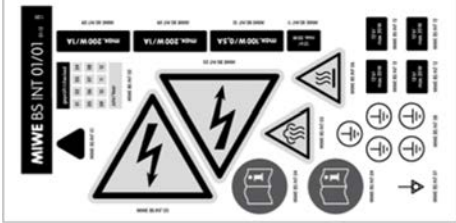
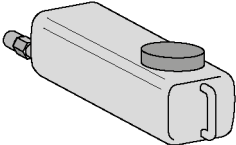
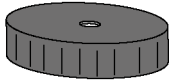
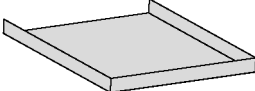
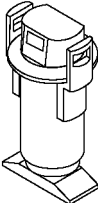
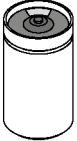
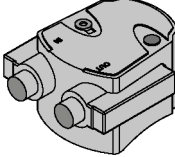

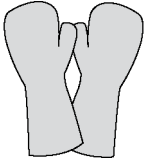




Image	Material number	Designation
	507340.04	MIWE baking symbol pictogram
	507330.00	Baking station signs and labels, international.
	088540.50	Water tank, complete
	506340.02	MIWE gusto tank cover
	On request	Baking tray
	506800.57	BRITA PURITY 450 STEAM WITH MDU
		Replacement cartridges
	506800.63	BRITA PURITY C150 Quell ST filter cartridge
	506800.64	BRITA PURITY 450 STEAM
	506800.39	BRITA PURITY C filter head 0-70% bypass
	506775.01	Stainless steel care spray, 500 ml

Image	Material number	Designation
	506773.01	'BRICKMAN' MIWE heat-resistant gloves
	506776.02	ALTEC L 250 oven cleaner (500 ml)
	188338.10	Box of 6 bottles MIWE cleaner CC3.0
	187961.60	"Drinking water" notice
	187961.70	"Not drinking water" notice

14. Shut-down and disposal

14.1. Safety information



RISK OF ELECTROCUTION!

Live lines can cause serious injury and even death.

- Before any work, switch off the power supply to the unit and make sure it cannot be switched back on, and check that no parts are live.



DANGER OF INJURY FROM FALLING PARTS!

Falling parts can cause serious injury and even death.

- Use the tools and equipment specified.



DANGER TO LIFE FROM GAS, WATER AND COMPRESSED AIR!



Escaping gas, water and compressed air can cause serious injury and even death.

- Disconnect and secure all supply lines to the unit before dismantling.

14.2. Environmental protection

- Remove all service fluids and parts that are in contact with these substances from the unit.
- Disassembled parts and waste must be disposed of by an authorised company in compliance with the provisions for recycling and special waste applicable at the place of installation.

15. EC declaration of conformity

<p>Declaration of EC conformity in accordance with EC Directive 2006/42/EC Annex II A relating to machinery</p>		
<p>We,</p>	<p>MIWE Michael Wenz GmbH Michael-Wenz-Str. 2-10 D - 97450 Arnstein</p>	
<p>declare that the design and construction of the product below for processing baked goods and the condition and form in which it has been put on the market by us complies with the applicable provisions of the above EC Directives.</p> <p>Changes to the product or to parts thereof shall render this declaration null and void.</p>		
<p>Machine type: Designation of type: Serial number: Year of construction:</p>	<p>Convection baking oven (Konvektionsbackofen) MIWE gusto 3.0 from 913086 from 2016</p>	
<p>Regulations applied:</p> <ul style="list-style-type: none"> • EC Directive 2006/42/EC, Annex I • EC Directive 2004/108/EC • EC Directive 2006/95/EC 		
<p>Harmonized standards applied:</p> <ul style="list-style-type: none"> • EN ISO 12100:2010 • EN 60335-1:2012 • EN 61000-6-2:2006 • EN 61000-6-3:2011 • EN 1672-2:2005+A1:2009 		
<p>Person authorized to draw up the documentation:</p>		
		<p>Dipl.-Ing. (FH) Bernhard Kusche MIWE Michael Wenz GmbH Michael-Wenz-Str. 2-10 D - 97450 Arnstein Telephon: +49 (0) 9363 68 8618</p>
<p>Arnstein, 2016-02-25</p>		
		
<p>----- CE-Manager Dipl.-Ing.(FH) Bernhard Kusche</p>		
<p>Author: Bernhard Kusche</p>	<p>Document: Serienkonfo_MIWE_gusto_3.0_ab_2016_EN.docx</p>	<p>Page 1 of 1</p>

Declaration of EC conformity

in accordance with EC Directive 2006/42/EC Annex II A
relating to machinery

MIWE

We, **MIWE Michael Wenz GmbH**
Michael-Wenz-Str. 2-10
D - 97450 Arnstein

declare that the design and construction of the product below for processing baked goods and the condition and form in which it has been put on the market by us complies with the applicable provisions of the above EC Directives.

Changes to the product or to parts thereof shall render this declaration null and void.

Machine type: Steam condenser (Schwadenkondensator)
Designation of type: MIWE gusto steam condenser
Serial number: from 1509013
Year of construction: from 2015

Regulations applied:

- EC Directive 2006/42/EC, Annex I
- EC Directive 2004/108/EC
- EC Directive 2006/95/EC

Harmonized standards applied:

- EN ISO 12100:2010
- EN 60335-1:2012
- EN 61000-6-2:2006
- EN 61000-6-3:2011
- EN 1672-2:2005+A1:2009

Person authorized to draw up the documentation:

Dipl.-Ing. (FH) Bernhard Kusche
MIWE Michael Wenz GmbH
Michael-Wenz-Str. 2-10
D - 97450 Arnstein
Telephon: +49 (0) 9363 68 8618

Arnstein, 2015-03-02



CE-Manager

Dipl.-Ing.(FH) Bernhard Kusche

Author:
Bernhard Kusche

Document:
Serienkonfo_MIWE_gusto_SK_ab_1509013_ab_2015_EN.docx

Page 1 of 1