

MIWE aero e+ with TC control system
Unit version 3.0

LEGAL NOTICE

This document is to be treated as confidential. It is intended solely for persons who work with the unit. This document may not be provided to third parties without the written consent of the manufacturer.



LEGAL NOTICE

The specifications, text, drawings, images and all other information and graphics contained in this document are protected by copyright and industrial property rights.

Persons making unauthorised commercial use of this document or its content shall be open to prosecution.

This document may not be reproduced in any way or form, in whole or in part, nor may its content be used and/or communicated without the written consent of the manufacturer. Parties breaching this provision shall be liable for damages. All rights reserved.

Copyright 2014 by
MIWE Michael Wenz GmbH
P.O. Box 20, D-97448 Arnstein
Phone +49-(0)9363-680
Fax +49-(0)9363-688400
e-mail contact@miwe.de
www.miwe.com

1.	IMPORTANT INFORMATION	7
1.1.	Intended use	7
1.2.	Foreseeable misuse	8
1.3.	Area of use	9
1.4.	Certification	9
1.4.1.	EC declaration of conformity	9
1.4.2.	CE mark	9
1.5.	About this documentation	9
1.6.	Explanation of symbols	10
1.6.1.	Warnings	10
1.6.2.	Special hazards	11
1.6.3.	Notes	11
1.7.	Limitation of liability	12
1.8.	MIWE service	12
2.	SAFETY	13
2.1.	Responsibility of the owner-operator	13
2.2.	Accident prevention and first aid	14
2.3.	Personnel	14
2.4.	Protective clothing	15
2.5.	Storage	16
2.6.	Signs and labels	17
3.	UNIT DESCRIPTION	19
3.1.	Scope of delivery	19
3.1.1.	Baking trays	20
3.2.	Design	21
3.2.1.	Single-circuit system	21
3.2.2.	Dual-circuit system	23
3.2.3.	MIWE backcombi	24
3.2.4.	Water tank system	25

3.3.	Functioning principle	27
3.4.	Safety devices	28
3.4.1.	Multiple glazing, oven door	28
3.4.2.	Safety temperature limiter	29
3.4.3.	Power supply	29
3.5.	Description of work areas	30
3.5.1.	Work area for operating personnel	30
3.5.2.	Work area for maintenance and cleaning personnel	30
3.6.	Castor types	31
3.6.1.	Castors with locking lever	31
3.6.2.	Castors with fastening screw	32
3.6.3.	Castors with fastening screw, adjustable	33
3.6.4.	Castors without brakes	34
4.	INSTALLATION BY MIWE SERVICE	35

5.	COMMISSIONING BY MIWE SERVICE	36
-----------	--------------------------------------	-----------

5.1.	Commissioning	36
5.1.1.	Training	36
5.1.2.	Handover to the owner-operator with a handover report	36
6.	OPERATION	37

6.1.	Safety instructions	37
6.2.	Operating modes	38
6.3.	User selection	39
6.3.1.	Changing users	39
6.4.	MIWE TC controls (Touch Control)	40
6.4.1.	About the operating unit	40
6.5.	Ready for operation	40
6.6.	Switching the controls ON / OFF	41
6.7.	OFF mode	41

6.8.	AUTOMATIC MODE	42
6.8.1.	Selecting a baking program	42
6.8.2.	Ready to bake	42
6.8.3.	OPEN / CLOSE baking chamber door	43
6.8.4.	Loading the oven	44
6.8.5.	Starting the baking process	45
6.8.6.	Cancelling the baking process	45
6.8.7.	Unloading the oven	45
6.9.	Managing baking programs	47
6.9.1.	Creating and changing baking programs	48
6.9.2.	Copying and pasting baking programs	52
6.9.3.	Deleting baking programs	53
6.10.	Special functions	54
6.10.1.	Recalibrating the screen	54
6.11.	Cleaning programs	55
7.	FAULTS	56

7.1.	Safety information	56
7.2.	What to do in the event of a fault	58
7.3.	Electrical and mechanical faults	59
7.3.1.	Actuating the safety temperature limiter	64
7.4.	Fault messages with fault codes – TC controls	64

8.	CLEANING AND CARE	65
8.1.	Safety information	65
8.2.	Cleaning schedule	66
8.3.	Cleaning	66
8.3.1.	Casing	67
8.3.2.	Operating unit	67
8.3.3.	Baking chamber	68
8.3.4.	Glass panel	69
8.3.5.	Door seal	70
8.3.6.	Tray supports	71
8.3.7.	Baking trays	72
8.3.8.	Collection channel for baking residue	73
8.3.9.	Water tank system	75
8.3.10.	Vents	77
8.4.	Cleaning programs for the baking chamber	78
8.4.1.	Safety information	78
8.4.2.	Checking the spray nozzle function	79
8.4.3.	Checking the door seal	80
8.4.4.	Check at the end of the cleaning program	80
8.5.	MIWE cleaning control cleaning program	81
8.5.1.	Safety information	81
8.5.2.	Filling up the cleaning agent	82
8.5.3.	Running a cleaning program	83

9.	INSPECTION AND MAINTENANCE	86
<hr/>		
9.1.	Safety information	86
9.2.	Maintenance schedule	88
9.2.1.	Maintenance by the owner-operator	88
9.2.2.	Maintenance/service by MIWE service	89
9.3.	Maintenance instructions	89
9.3.1.	Cleaning the siphon	89
9.3.2.	Rinsing the water drainage hoses	92
9.3.3.	Changing the door seal	93
9.3.4.	Cleaning the filter in the water system connection piece	94
9.3.5.	Replacing the silicone buffers	96
9.3.6.	Changing the stop buffers	97
9.3.7.	Changing magnets on the door frame	100
9.3.8.	Replacing lamps	102
9.4.	Start-up after maintenance	103
10.	TECHNICAL DATA	104
<hr/>		
10.1.	Technical data – product versions	104
10.2.	Rating plate	105
11.	WEAR AND SPARE PARTS LIST	106
<hr/>		
12.	SHUT-DOWN AND DISPOSAL	110
<hr/>		
12.1.	Safety information	110
12.2.	Environmental protection	110
13.	EC DECLARATION OF CONFORMITY	111
<hr/>		
14.	BAKING PROGRAMS	112
<hr/>		
14.1.	Baking tips	113
14.2.	Sample programs	114

1. Important information

1.1. Intended use

The MIWE aero e⁺ is an electric oven for commercial use. It is suitable for baking, cooking, roasting and heating food in accordance with current food regulations.

The oven must not be operated in publicly accessible areas.

Exception:

The oven has a key lock and a door lock.

The main modules are as follows:

Oven

The MIWE aero e⁺ can operate either

- as a convection oven or
- as a steamer

It can consist of up to two baking chambers, one above the other. The baking chambers are operated separately.

All products must be baked on baking trays.

Vapour hood with steam condenser

- Any smells and vapour produced are collected and extracted.
- Steam produced is condensed. The dry waste air and the condensate are discharged separately.

Vapour hood with condensate container

- Any smells and vapour produced are collected and extracted.
- Steam produced during baking is extracted into the owner-operator's ventilation system.

Base frame

- Mechanical base with castors, available in various heights.

Intermediate compartment

- Mechanical base

Proofing cabinet

- For controlling temperature and humidity in defined proofing processes.
- For keeping products warm and for drying products.

Products may only be proofed, kept warm or dried on trays.

Water tank system

- To supply water to up to 3 units from a drinking water canister if there is no fixed water connection.

Mechanical and electrical safety devices

- For safe operation

Process controls with operating unit



WARNING!

The oven is suitable for products with a natural alcohol content of up to a max. of 1 % by weight.

The unit may not be used for products containing an excessive amount of volatile compounds (such as are formed when ingredients with a high alcohol content are added) as these can produce high levels of inflammable vapours and therefore pose a significant risk.



SERVICE INFORMATION

The specifications for commissioning, start-up, operation, maintenance and repair must be complied with.

1.2. Foreseeable misuse

The oven may only be used for the purpose described here.

All other uses are incorrect and are strictly prohibited. Incorrect uses include:

- Tampering with safety devices
- Baking, heating or drying other substances or organisms
- Use in the home / domestic-scale kitchens
- The unauthorised connection of other units to the MIWE oven
- Connection to an unsuitable power supply



LEGAL NOTICE

The manufacturer shall not be liable for damage which occurs as a result of incorrect use.

1.3. Area of use

Enclosed areas on commercial premises, e.g.:

- Sales areas closed off to public access
- Bakeries
- Snack bars
- Canteens
- Restaurants
- Hospitals
- Butcher's shops

1.4. Certification

1.4.1. EC declaration of conformity

MIWE issues a manufacturer EC declaration of conformity pursuant to the EC Machinery Directive 2006/42/EC, Annex IIa and EN ISO/IEC 17050-1. The declaration of conformity is an integral part of the overall documentation.

1.4.2. CE mark



The manufacturer has awarded the CE mark on the basis of the declaration of conformity. The information on intended use and misuse and the safety information in this documentation is based on a risk assessment in accordance with DIN EN ISO 12100.

1.5. About this documentation

It is important that you observe all safety information and handling instructions to ensure safety on the job. The applicable local accident prevention and general safety regulations for the area of use must also be observed.

Please read the documentation carefully before beginning any work. It is an integral part of the product and must be accessible to staff at all times. If passing on the unit to third parties, also provide them with the documentation. The figures/illustrations contained in the documentation are provided for explanatory purposes only and may in the interests of clarity not necessarily be to scale. They may vary slightly from the actual version supplied.

1.6. Explanation of symbols

1.6.1. Warnings

Warnings are marked in this documentation by symbols.

The warnings are introduced by signal words which reflect the level of potential danger. You must observe the warnings and act with all due care in order to avoid accidents, injury and damage.



DANGER!

Indicates serious hazards which could lead to death or serious injury if not avoided. This symbol is only used for serious dangers.



WARNING!

Indicates moderate risk. Disregarding the safety instructions can lead to serious injury or death. This symbol is not used for risk of mere damage to property.



CAUTION!

Indicates dangers which pose only a minor risk of physical injury. This symbol is only used for risk to property.

1.6.2. Special hazards

The following symbols are used in conjunction with the safety information to indicate special hazards:



RISK OF ELECTROCUTION!

Indicates safety information regarding electric current or voltage. Failure to attend to this information can lead to serious injury or death. Work may only be carried out by specially qualified personnel. National and regional regulations in this area must be adhered to.



HEAVY LOADS CAN CAUSE INJURY!

Indicates safety instructions for handling heavy loads. Failure to attend to this information can lead to serious injury or death.



HOT SURFACES CAN CAUSE INJURY!

Indicates safety information relating to hot surfaces. Failure to attend to this information can lead to serious injury.



CRUSH HAZARD!

Indicates safety instructions for handling moving components. Failure to attend to this information can lead to serious injury or death.



RISK OF INJURY FROM HOT STEAM!

Indicates safety information on the risk posed by escaping hot steam. Failure to attend to this information can lead to serious injury.

1.6.3. Notes



NOTE!

Highlights useful tips, suggestions and information for ensuring efficient and smooth operation.



LEGAL NOTICE

Indicates information on statutory guidelines and standards and legally binding agreements between manufacturer and owner-operator.



SERVICE INFORMATION

Indicates information on cleaning, care, maintenance, lubrication and servicing.



PROCEDURE

Sets out procedures to be followed by operating and service personnel.

1.7. Limitation of liability

All the information, notes and instructions contained in the documentation have been prepared in accordance with the applicable standards and regulations and the state of the art and on the basis of our extensive knowledge and experience. The manufacturer can accept no liability for loss arising from:

- Failure to follow this instruction handbook
- Incorrect use
- The use of untrained personnel
- Unauthorised modifications
- Technical modifications
- The use of unauthorised spare parts.

The actual scope of delivery may vary from that described and depicted in this handbook if a special version is delivered or additional options are ordered or if the latest technical modifications have been incorporated. The obligations agreed in the delivery contract, the General Terms and Conditions of Business and the Terms and Conditions of Delivery of the manufacturer and the statutory regulations valid at the time of the conclusion of the contract apply. We reserve the right to make technical changes in the interests of further development and the improvement of performance characteristics.

1.8. MIWE service

MIWE service provides a MIWE helpline to deal with all questions relating to MIWE products. MIWE service provides advice and support in the following areas:

1. Inspection
2. Maintenance
3. Individual service agreements covering:
 - Maintenance
 - Extended warranty
 - Repair
 - Modernisation
 - Overhaul
 - Commissioning and start-up
4. MIWE spare parts

For further information on MIWE service, details of the individual services and the competent contact persons, simply contact us by telephone, fax or e-mail or check on the Internet.

Our staff are always interested in hearing any new information you gain from using the unit which could help us improve our products.

2. Safety

This section covers all essential safety aspects so as to ensure the best possible protection for personnel and safe and smooth operation. Failure to adhere to the instructions and safety information in the instruction handbook can result in significant danger to personnel and damage to the product.

2.1. Responsibility of the owner-operator

Owner-operator

The person who operates the unit themselves for commercial or business purposes or makes it available to a third party for use or application and bears the legal product responsibility for the protection of users or third parties during operation.



NOTE!

The product is for use in the commercial sector. The owner-operator is therefore bound by statutory duties regarding health and safety at work. In addition to the safety information contained in this document, the applicable safety and accident prevention regulations and environmental standards for the unit's area of application must also be observed.

The owner-operator must:

- familiarise themselves with the applicable industrial health and safety regulations and conduct a risk assessment to establish any hazards resulting from the specific working conditions at the place of installation. The owner-operator must cover these hazards and regulations in operating instructions.
- throughout the product's entire useful life, keep checking whether the operating instructions drawn up still comply with the current rules and regulations. If they do not, they must be adapted accordingly.
- clearly define and regulate responsibility for operation, maintenance and cleaning.
- make sure that all employees handling the product have read and understood this document.
- provide personnel with regular training and inform them about the hazards.
- make sure that the unit is kept in perfect technical condition.
- make sure that the maintenance intervals are adhered to.
- check all safety devices regularly to make sure that they are complete and in good working order.
- always ensure that all housing elements and components are properly fitted before the unit is switched on.



SPECIAL DUTIES

The owner-operator must appoint a safety officer to monitor the safety devices and adherence to the safety measures.

2.2. Accident prevention and first aid

The owner-operator shall ensure safe operation and rapid help in emergency situations by putting suitable measures in place. The owner-operator shall:

- provide protective clothing for the operating and maintenance personnel.
- ensure the work area is properly lit for all work.
- prevent unauthorised access to the work area during operation by putting in place suitable protection and barriers.
- mark hazards and hazardous areas with warning signs or sounds; put in place barriers, covering for edges etc.
- ensure all safety and warning signs on the product are kept in a legible condition.
- display an evacuation plan in the unit and operating area and keep all emergency exits and escape routes clear.
- Provide fully functional and easily accessible fire extinguishers, first aid boxes, eye wash facilities and emergency telephones.

2.3. Personnel



WARNING: DANGER FOR UNAUTHORISED PERSONS!

Unauthorised persons who do not meet the requirements are not familiar with the hazards in the work area.

- Keep unauthorised persons away from the work area.
- If in doubt, speak to the persons concerned and send them out of the work area.
- Stop work until all unauthorised persons have left the work area.

Qualified personnel

Qualified personnel are able to perform the tasks assigned to them and to recognise potential hazards on the basis of their professional training, knowledge and experience and their knowledge of the relevant laws and regulations.

Trained personnel

A trained person has been trained in the procedures and technology of the unit by the manufacturer and has been informed of potential hazards resulting from incorrect handling.

Instructed personnel

Instructed personnel have been instructed by the owner-operator about the tasks they are to perform and have been informed about the potential hazards of incorrect operation.

Authorised personnel

Persons are authorized as personnel only if they can be expected to perform their work reliably. Persons whose reactions are affected by, for example, drugs, alcohol or medication are not authorized. Age- and occupation-specific regulations in force at the place of use must be observed when selecting personnel.

2.4. Protective clothing

Protective clothing must be worn for work to minimize health risks.

**PROTECTIVE CLOTHING**

- To protect from burns from hot surfaces and vapour.
Protective clothing must have long sleeves and long legs.

**PROTECTIVE GLOVES**

- To protect the hands from burns from hot surfaces and vapours and from rubbing, grazing, jabbing or deeper wounds.

Special protective clothing for certain work

Additional protective clothing is required when carrying out some jobs. This is highlighted in the relevant sections of this handbook.



SAFETY GOGGLES

- To protect the eyes from splashes and hot vapours.



SAFETY SHOES

- To protect the feet from heavy falling objects.



HEARING PROTECTION

- To prevent hearing damage from noise emissions.



LIGHTWEIGHT RESPIRATORY EQUIPMENT

- To protect from harmful dusts and vapours.



CHEMICAL-RESISTANT PROTECTIVE GLOVES

- To protect the hands from aggressive substances. Check gloves for leaks before use. Clean the gloves before taking them off. Store them in a well-ventilated place.

2.5. Storage

Store the product in the following conditions:

- Do not store outdoors.
- Store in a dry and dust-free place.
- Do not expose to aggressive substances.
- Keep out of sunlight.
- Avoid mechanical shocks.
- Storage temperature: +3°C to +50°C.
- Relative humidity: max. 60%.
- If the unit is in storage for longer than 3 months, the general condition of all the parts must be checked regularly.

2.6. Signs and labels



WARNING: ILLEGIBLE SYMBOLS CAN RESULT IN INJURY!

Signs and labels indicate potential hazards and special technical functions. Stickers and signs can over time become dirty or otherwise illegible.

- Ensure all safety signs, warning signs and operating instructions are kept in a legible condition.
- Replace damaged signs or stickers immediately.

Front



HOT SURFACE

Hot surfaces, such as hot unit components and hot fluids, are not always recognisable as such. Do not touch them unless you are wearing protective gloves.



HOT STEAM!

Escaping hot steam can scald. In areas marked by this sign, always be careful and wear suitable personal protective equipment (protective clothing, protective gloves, safety goggles).

Back



VOLTAGE

Indicates areas in which only qualified electricians may work.



OBSERVE THE INSTRUCTION HANDBOOK

Only use the marked item after having read the instruction handbook.



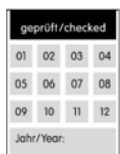
SOCKET LABELLING

Indicates the power rating of the socket.



EQUIPOTENTIAL BONDING

Indicates the position of the bolt for connecting the equipotential bonding conductor.



TEST STICKER

Shows the date on which the electrical system of the unit was tested.

Inside of door**LIGHTING LABELLING**

Indicates the power rating of the lighting.

Drinking water and wastewater canister - water tank system

The unit can be fitted with a water tank system (optional).
The unit has the following stickers in line with this option.

**DRINKING WATER**

Only fill the canister with drinking water.

**NOT DRINKING WATER**

The water in the canister is not drinking water.

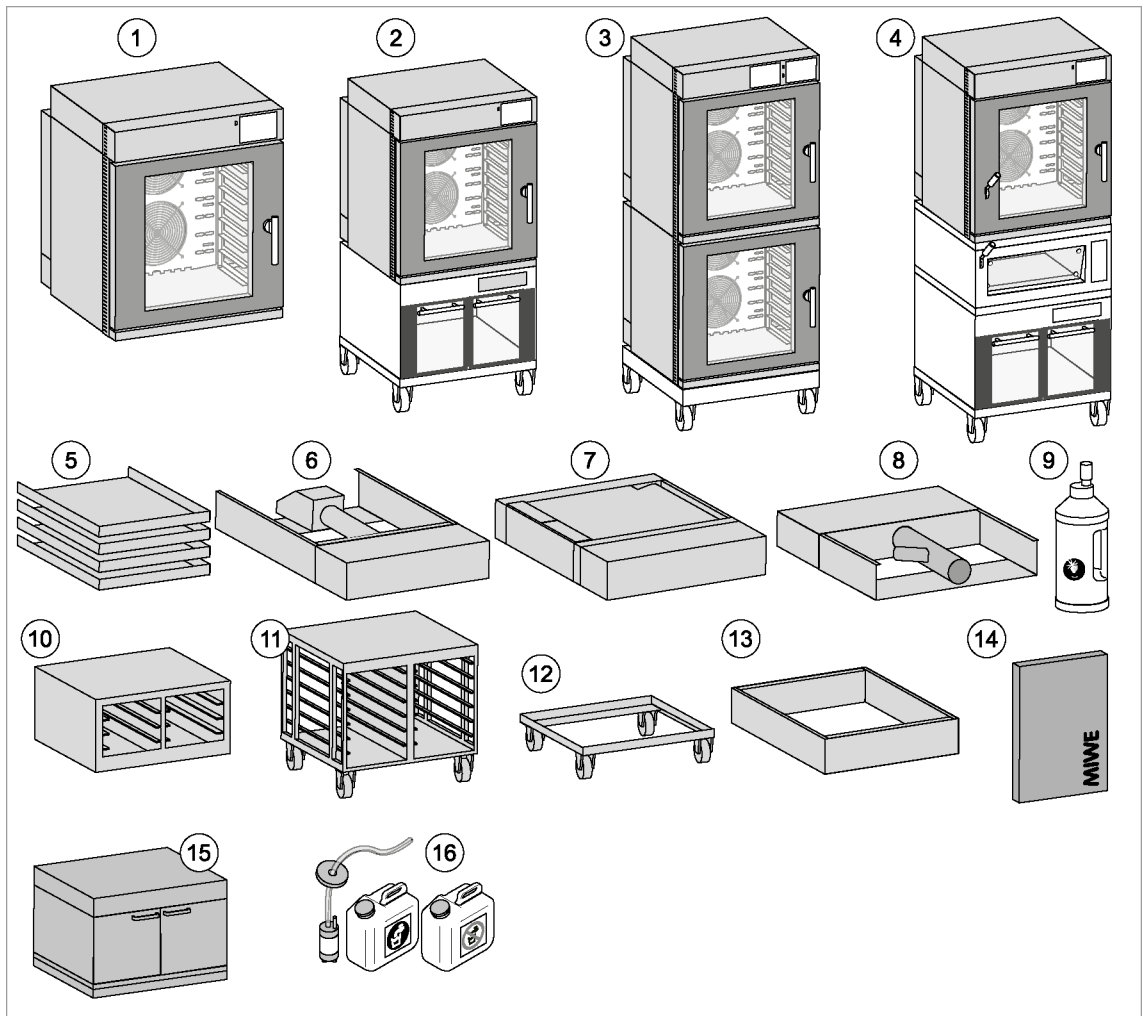
3. Unit description

3.1. Scope of delivery

**NOTE!**

The scope of delivery depends on the order.

For the MIWE GS proofing cabinet and vapour hood versions (extraction systems), please see the separate instruction handbooks.



- | | |
|--|--|
| ① Single-circuit system | ⑨ Cleaning agent (optional) |
| ② Baking station; oven with proofing cabinet | ⑩ Intermediate compartment |
| ③ Dual-circuit system | ⑪ Base frame with castors |
| ④ MIWE backcombi | ⑫ Base with castors |
| ⑤ Baking trays (optional) | ⑬ Panel, extension frame |
| ⑥ Vapour hood with condensate container (optional) | ⑭ Documentation |
| ⑦ Vapour hood with steam condenser (optional) | ⑮ Base frame with casing and doors; for version with water tank system |
| ⑧ Vapour hood with fan (optional) | ⑯ Water tank system (optional) |

3.1.1. Baking trays

You will have to observe general instructions before baking for the first time.

Further information can be found in the 'Cleaning and care' section under 'Cleaning – Baking trays'.

3.2. Design

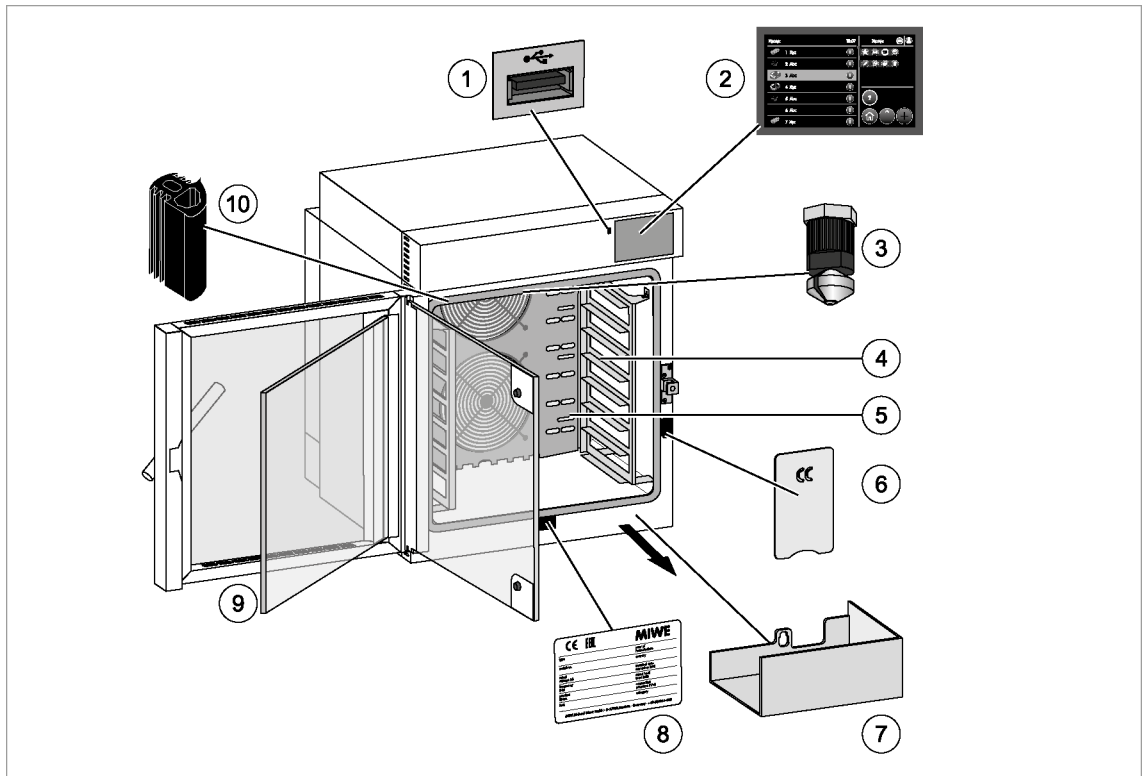


NOTE!

The detailed technical data is sent to the owner-operator together with the order confirmation.

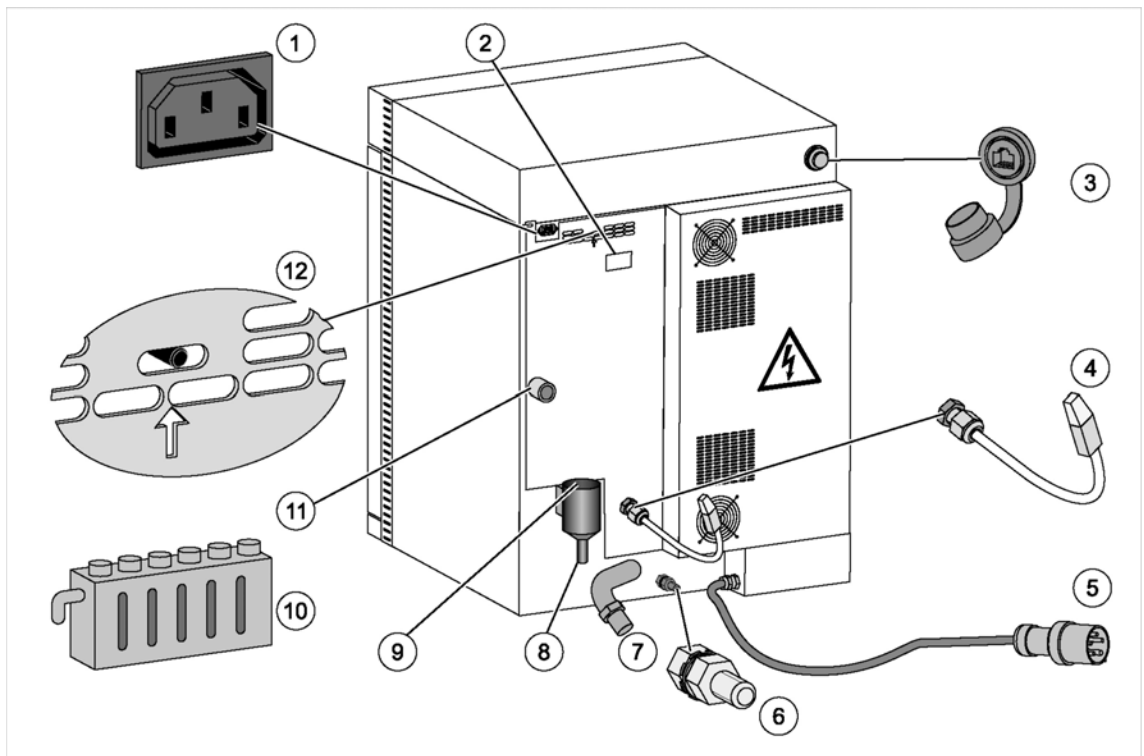
3.2.1. Single-circuit system

Front section



- ① USB port with protective cap
- ② Operating unit
- ③ Spray nozzle (optional), only with MIWE cleaning control
- ④ Tray supports, detachable
- ⑤ Suction plate, detachable and adjustable
- ⑥ Filling opening for cleaning agent (optional)
- ⑦ Collection channel, detachable
- ⑧ Rating plate
- ⑨ Baking chamber door with triple glazing (optional)
- ⑩ Door seal

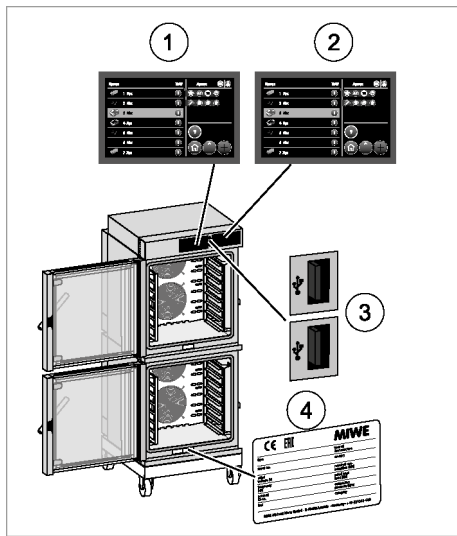
Back



- ① Device socket for vapour hood with steam condenser or fan (optional)
- ② Rating plate
- ③ RJ-45 network interface (optional)
- ④ Remote display floating contact (optional)
- ⑤ Connecting power cable
- ⑥ Equipotential bonding connection
- ⑦ Baking chamber water drain
- ⑧ Condensate drain connection
- ⑨ Steam discharge connection
- ⑩ Siphon (optional)
- ⑪ Water connection
- ⑫ Safety temperature limiter

3.2.2. Dual-circuit system

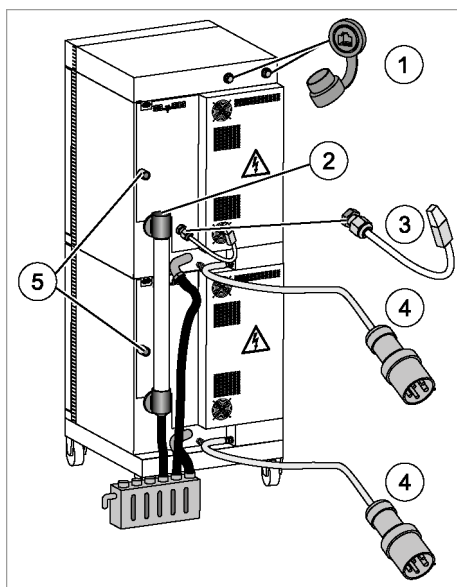
Front section



- ① Operating unit for top baking chamber
- ② Operating unit for bottom baking chamber
- ③ USB port with protective cap, x 2
- ④ Rating plate for complete unit

For further information, please see 'Front section' in 'Single-circuit system'.

Back



- ① RJ-45 network interface (optional)
- ② Joint connection for steam outlet
- ③ Remote display floating contact (optional)
- ④ Connecting power cable
A joint connecting power cable for both ovens can be fitted in line with the order.
- ⑤ Water connection
Depending on the order, the following may be fitted:
 - A joint water connection for both ovens
 - Filters, pressure regulators or a water treatment system.

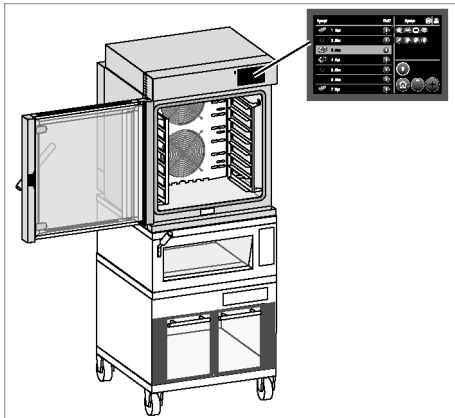
For further information, please see 'Back' in 'Single-circuit system'.

3.2.3. MIWE backcombi

The figure shows one of the many possible combination systems:

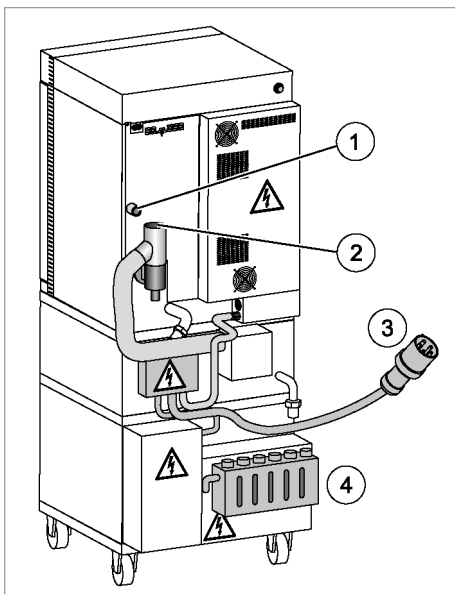
- Convection oven with
- MIWE condo deck oven and
- MIWE GS proofing cabinet.

Front section



For further information, please see 'Front section' in 'Single-circuit system'.

Back



- ① Water connection
Depending on the order, the following may be fitted:
 - A joint water connection for both ovens
 - Filters, pressure regulators or a water treatment system.
- ② Steam outlet connection for MIWE convection oven or complete combination system
- ③ Connecting power cable
- ④ Joint siphon

For further information, please see 'Back' in 'Single-circuit system'.



NOTE!

If the safety temperature limiter of a MIWE backcombi unit trips, only this unit will be switched off. The other units will remain fully operational.

3.2.4. Water tank system

If there is no fixed water connection, the unit can be operated with a water tank system.

Water is supplied from a drinking water canister and discharged into a wastewater canister.



NOTE!

Units with automatic cleaning systems cannot be operated with water tank systems.

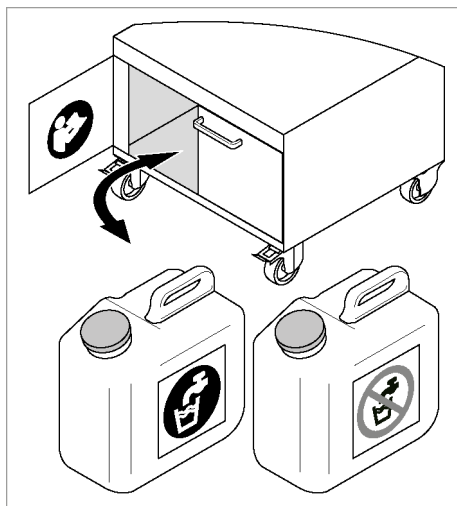


WARNING: DIRTY WATER IS A HEALTH RISK!

Dirty water encourages the growth and development of harmful microorganisms. Inhaling and ingesting these organisms can damage your health.

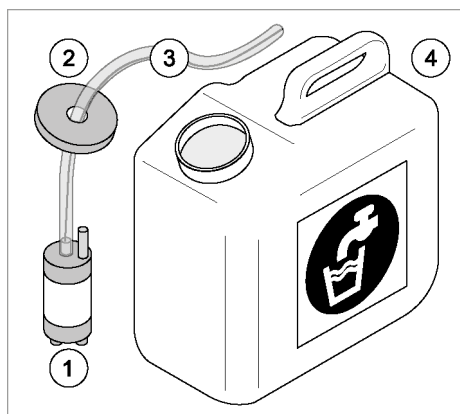
- Empty and clean the drinking water and wastewater canisters every day.
- Always rinse out the drinking water and wastewater canisters with hot water before you refill them.

Further information can be found in the 'Cleaning and care' section under 'Cleaning' – 'Water tank system'.

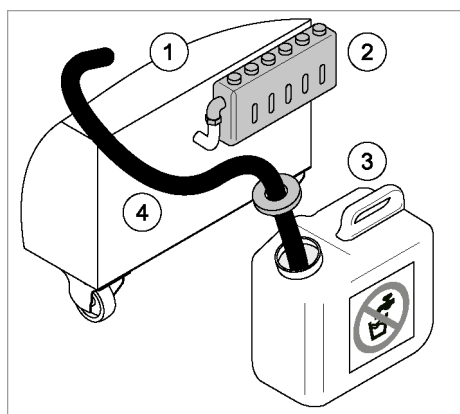


During operation, the drinking water and wastewater canisters are located in the base frame.

Monitor the levels in the canisters during operation and top up or empty as required.

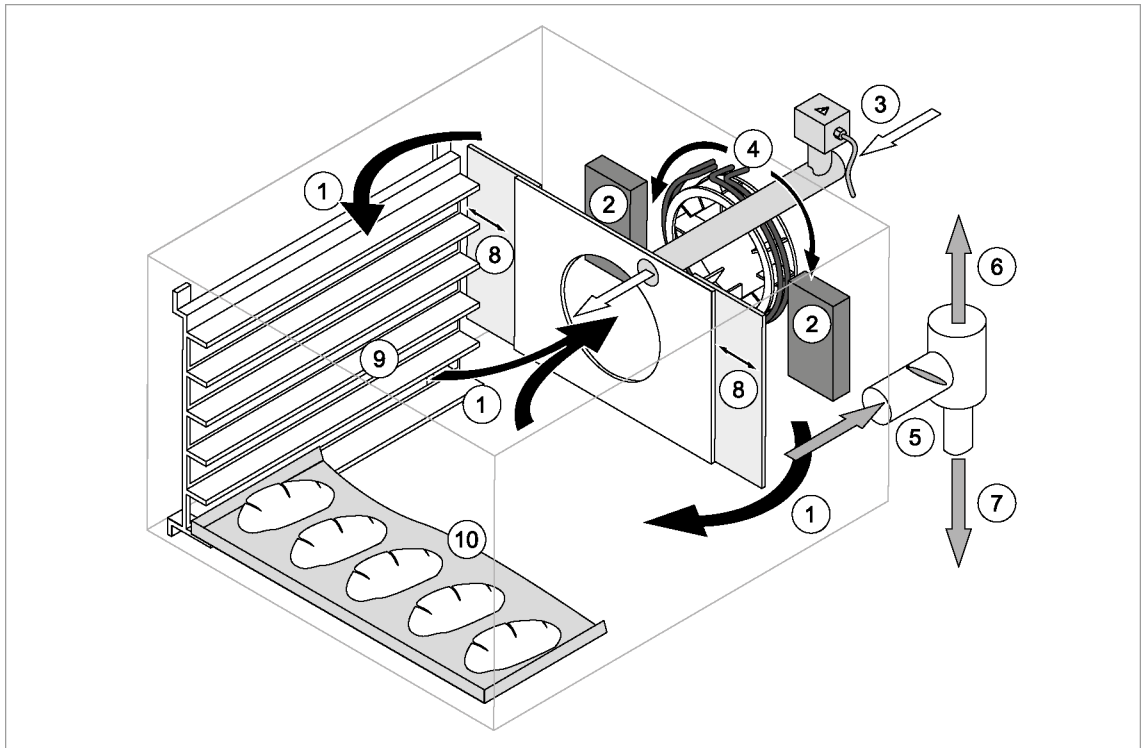
Drinking water canister

- ① Submersible pump
- ② Cover
- ③ Fixed hoses and electrical cable; fixed connection in base frame
- ④ Drinking water canister

Wastewater canister

- ① Base frame
- ② Siphon (optional)
- ③ Wastewater canister
- ④ Water drainage hose
Fixed connection at the back wall to the
 - siphon
 - or
 - baking chamber drain

3.3. Functioning principle



- ① There is a central air intake in the baking chamber and the air is then circulated.
- ② Steam devices supply steam to the baking chamber if required.
- ③ Fresh air supply with electric actuator.
- ④ Electric heating elements heat up the air in the baking chamber and an impeller circulates the hot air in the baking chamber.
- ⑤ Steam discharge
- ⑥ Steam is extracted from the baking chamber.
- ⑦ Any condensate which forms runs into the siphon.
- ⑧ Adjustable air deflectors change the air circulation in the baking chamber and therefore the results (depends on size).
- ⑨ The tray supports can be easily removed for cleaning.
- ⑩ Loaded baking trays rest on tray supports.

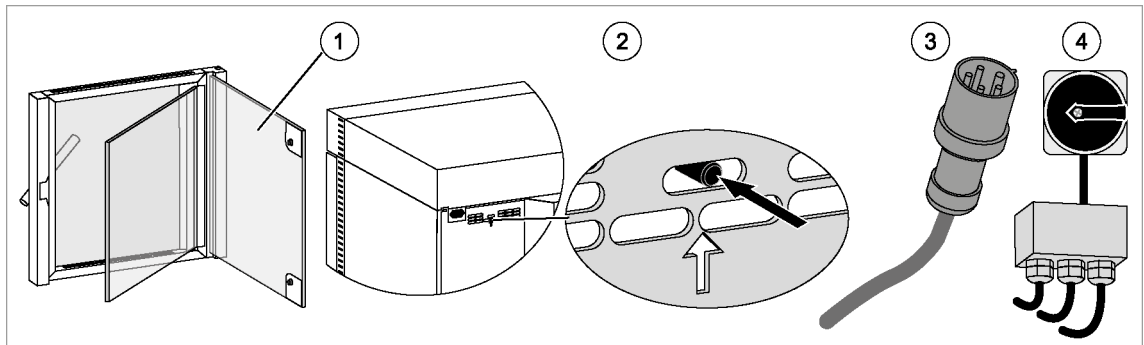
3.4. Safety devices



DANGER: RISK OF INJURY AND DAMAGE TO THE UNIT!

Changes to the safety devices can pose a safety risk and render the operating licence / warranty void.

- Never tamper with or make unauthorised adjustments to the safety devices.
- Any and all adjustments must be carried out by MIWE service.
- Document the subsequent acceptance and inspection and have these approved.



- ① Triple glazing (optional)
② Safety temperature limiter

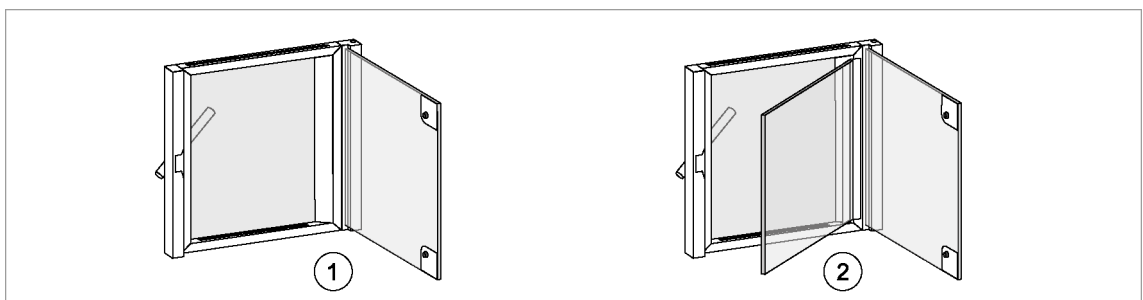
- ③ Electrical plug and socket connection
④ All-pole circuit breaker master switch

3.4.1. Multiple glazing, oven door

Prevents the front from getting hot.

Glazing options

The number of glass panels depends on the order.



- ① Double glazing

- ② Triple glazing, additional middle glass panel

3.4.2. Safety temperature limiter

Monitors the temperature in the baking chamber

If the maximum temperature (preset) is exceeded:

- the safety temperature limiter trips.
- the electric drives and heating are switched off.
- the operating unit remains on.
- a fault message is shown.

For further information, please see 'Faults'.

3.4.3. Power supply

The power connection must be easily accessible at all times.

It must be possible to rapidly disconnect the power supply in the event of danger.

Disconnecting the unit power supply



1. Disconnect electrical plug and socket connection
- or
1. Switch the master switch OFF.

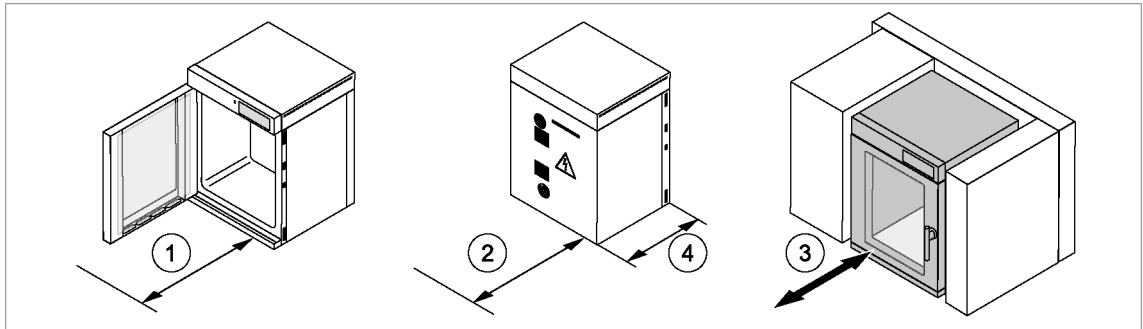
For further information, please see the 'Essential preparations'.

3.5. Description of work areas



WARNING!

The work areas for operating, maintenance and cleaning personnel must not be obstructed by objects or fixtures.



- | | |
|---|-------------------|
| ① Work area for operating, maintenance and cleaning staff | ③ Moving the unit |
| ② Work area for maintenance and cleaning personnel | ④ Total depth |

3.5.1. Work area for operating personnel

The work area is located in front of the oven and has space for operating, loading and unloading the oven.

Recommended minimum work area depth: Total depth +50 cm.

3.5.2. Work area for maintenance and cleaning personnel

The work areas are located

- in front of the oven
- at the back of the oven
- at the sides of the oven

If the unit is fixed or stands with its back against a wall, it will need to be moved for maintenance and cleaning. Move the unit using suitable lifting gear (forklift) or rotate it to ensure there is enough space to work.

Recommended minimum work area depth: Total depth +50 cm.

3.6. Castor types

The unit can come with any of various types of castors depending on the model.



CAUTION: RISK OF INJURY FROM THE UNIT SLIDING AND MOVING UNEXPECTEDLY!

If the unit's castors are not locked in place, the unit may slide or move.

- Always lock the unit's castors in place if you do not want to move it.
- Do not move the unit further than the connected lines and hoses allow.
- Only release the castors if the place of installation is to be changed.

3.6.1. Castors with locking lever

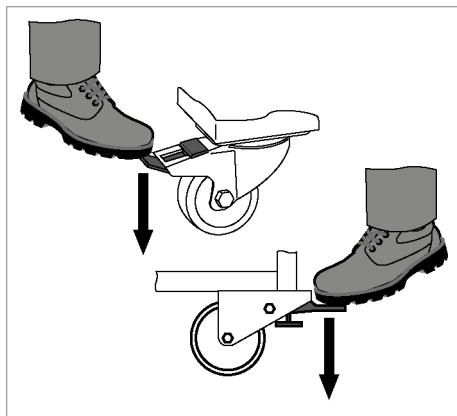


CRUSH HAZARD WHEN RELEASING AND LOCKING LOCKING LEVERS!

Operating locking levers can cause injuries through pinching or crushing.

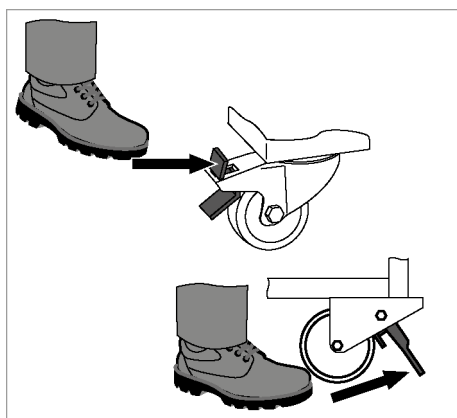
- Wear safety shoes at all times when working at the unit.
- Never operate the locking lever with your hands.

Securing



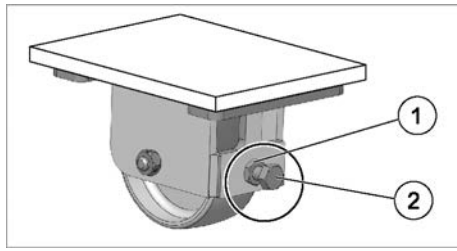
1. Push down the locking lever with your foot until the lever locks into place.

Releasing



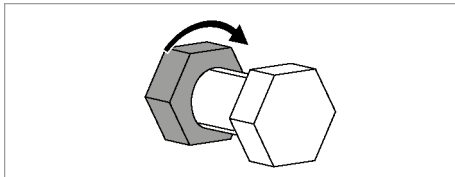
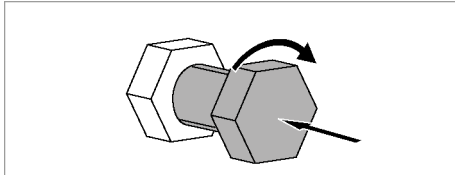
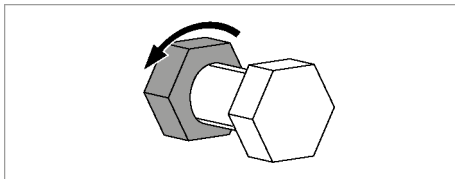
1. Disengage the locking lever from the castor with your foot.

3.6.2. Castors with fastening screw



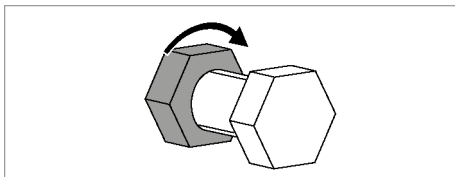
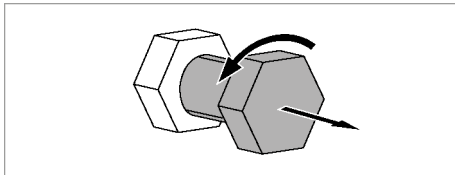
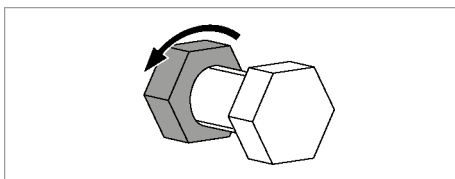
- ① Locknut
- ② Fastening screw

Securing



1. Unscrew locknut with a suitable tool.
2. Tighten the fastening screw with a suitable tool.
3. Tighten the locknut with a suitable tool.

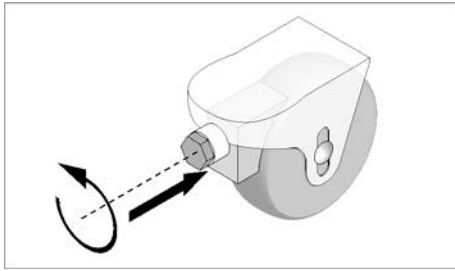
Releasing



1. Unscrew locknut with a suitable tool.
2. Loosen the fastening screw with a suitable tool.
3. Tighten the locknut with a suitable tool.

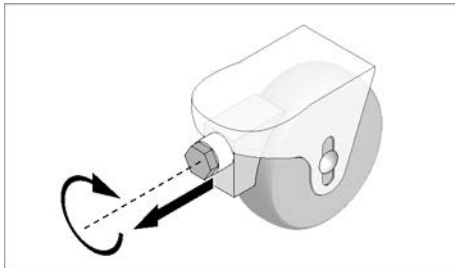
3.6.3. Castors with fastening screw, adjustable

Securing



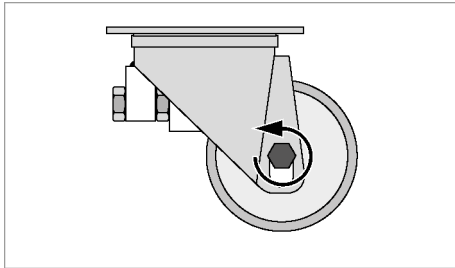
1. Tighten the fastening screw with a suitable tool.

Releasing

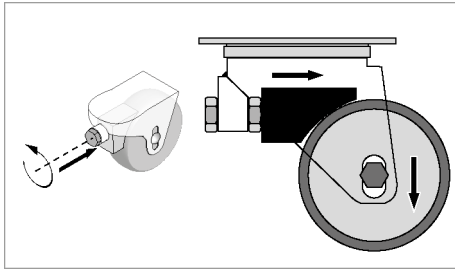


1. Loosen the fastening screw with a suitable tool.

Adjusting the height

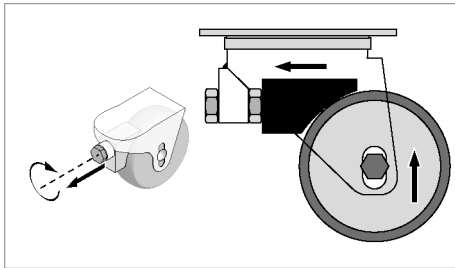


1. Using suitable tools, loosen the hexagon nut in the castor bracket.

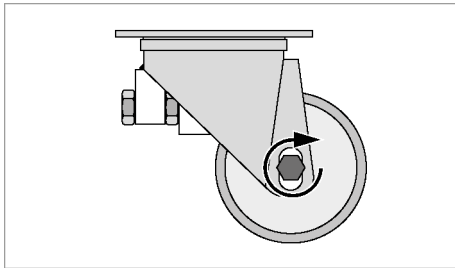


2. Using suitable tools, turn the fastening screw anti-clockwise to increase the castor height.

or

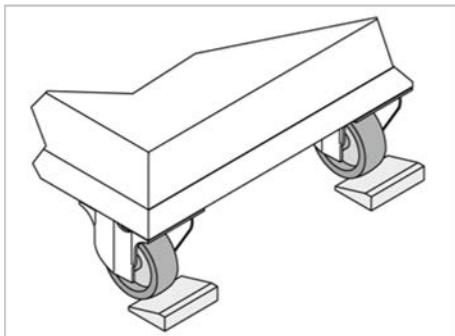


2. Using suitable tools, turn the fastening screw clockwise to reduce the castor height.



3. Using suitable tools, tighten the hexagon nut in the castor bracket.

3.6.4. Castors without brakes



1. Secure the castors with wedges.

4. Installation by MIWE service



DANGER OF INJURY AND DAMAGE TO THE UNIT!

Installation must be carried out by trained, qualified personnel with the necessary experience (certified).

Errors in installation can result in life-threatening situations and cause serious damage.

- All installation work must be left strictly to MIWE service or an authorised partner of MIWE service.
- Consult MIWE service or an authorised partner of MIWE service if the unit is subsequently to be moved.
- Work on the electrical equipment must be carried out by qualified electricians.
- Never modify or adjust the electrical or mechanical equipment or safety components.

5. Commissioning by MIWE service

5.1. Commissioning



NOTE!

Before commissioning, you must make sure that installation is correct and complete.

The manufacturer provides the following services to the owner-operator as part of commissioning:

- Inspection of the electrical and mechanical equipment and the safety devices.
- Trial operation in cooperation with the owner-operator.
- Training
- Handover of the unit to the owner-operator with a handover report.

5.1.1. Training

Instruction and training by the manufacturer begins after successful trial operation. Instruction and training is provided for:

- Operating personnel
- Maintenance personnel

5.1.2. Handover to the owner-operator with a handover report

Following successful trial operation, instruction and training, the unit is handed over to the owner-operator. The following services are provided:

- Handover of complete documentation.
- Completion of the handover report and signature by the owner-operator and the manufacturer.

This handover report remains an integral part of the complete documentation.



WARRANTY

Responsibility for the unit is transferred to the owner-operator upon handover and signature of the report.

6. Operation

6.1. Safety instructions



INCORRECT OPERATION CAN CAUSE INJURY!

Incorrect operation can result in serious injury and damage.

- Always read the relevant section of this instruction handbook before each stage in operation.
- Carry out all steps according to the instructions in this instruction handbook.
- Only allow trained personnel to operate the unit.



DEFECTS IN THE UNIT CAN CAUSE INJURY!

Defects in the unit can result in serious injury and damage.

- Check the unit for visible defects before switching it on.
- If you find any defects, immediately disconnect the unit from the power supply and contact MIWE service.



BAKING CHAMBER DANGEROUS FOR PEOPLE AND ANIMALS!

The high temperatures inside the baking chamber pose a danger to life.

- Always make sure that there are no persons or animals in the baking chamber before starting to bake.



CRUSH HAZARD WHEN OPENING AND CLOSING DOORS!

You may injure yourself when opening and closing doors improperly.

- Wear the prescribed protective clothing for all work.
- Use the door handle.



CAUTION: DAMAGE TO THE SURFACE OF THE OPERATING UNIT!

Sharp objects may damage the surface of the operating unit.

- Only operate the operating unit with your hands.



NOTE!

Always observe the specific safety instructions for each operation!

Protective clothing

Protective clothing must be worn for work to minimize health risks.



PROTECTIVE CLOTHING

- To protect from burns from hot surfaces and vapour. Protective clothing must have long sleeves and long legs.



PROTECTIVE GLOVES






- To protect the hands from burns from hot surfaces and vapours and from rubbing, grazing, jabbing or deeper wounds.







SAFETY GOGGLES

- To protect the eyes from splashes and hot vapours.

6.2. Operating modes

	Baking	<ul style="list-style-type: none"> • Baking with baking programs • Manual change (not as Easy user)
	OFF mode	<p>This function prevents accidental activation.</p> <ul style="list-style-type: none"> • Baking not possible. <p>Requirement for:</p> <ul style="list-style-type: none"> • AUTOSTART • Automatic cleaning
	AUTOSTART	The unit switches on automatically and is ready to bake at the set autostart time.
	MIWE Eco-Modus mode	The energy-saving function reduces the energy consumption of the unit when it is switched on but not in continuous use. The temperature in the baking chamber is kept at a constant, reduced level.
	Cleaning	<p>The baking chamber is cleaned or descaled with an automatic program.</p> <p>Four different programs are available to choose from</p>

6.3. User selection

	Easy	<ul style="list-style-type: none"> • Baking with baking programs • Access to the most important functions
	Profi	<ul style="list-style-type: none"> • Baking with baking programs and manual changes • Advanced settings • Detailed displays • Baking program creation and editing
	Admin	All rights are available.
	Service	Only for MIWE service or qualified personnel authorised by MIWE.

6.3.1. Changing users



1. Touch the USER button.
The display changes in line with the selected user.
2. Touch the required button.
The current mode will be displayed.

Further information



1. Touch the HELP button.
A menu with additional information will open.

6.4. MIWE TC controls (Touch Control)

The controls are operated using a touch-screen on the front.



Switch the power ON.

- The user interface will appear on the screen after c. 20 seconds.

Different buttons and parameters will appear depending on the mode and operation.

6.4.1. About the operating unit

The screen has a touch-sensitive surface.

All entries and settings are made on the screen.



NOTE!

If the screen does not respond when touched or implements a function for a button other than the one touched, the screen needs to be recalibrated.

For further information, please see 'Recalibrating the screen' in 'Operation - Special functions'.



NOTE!

You can switch between different views by swiping.

6.5. Ready for operation

Establishing operating status



1. Open the cold water supply line.
2. Check the electrical connection is secure and undamaged.
3. Check for damage to waste water and ventilation system.
4. Switch power supply ON.



CAUTION: FOREIGN OBJECTS CAN CAUSE DAMAGE!

Foreign objects can melt or burn and damage the unit.

- Make sure that there are no foreign objects inside the unit before switching it on.

Ending operating status



1. Close the cold water supply line.
2. Switch the controls OFF.
3. Disconnect the unit power supply.

6.6. Switching the controls ON / OFF

Switching the controls ON



1. Touch the ON / OFF button until the illuminated circle around the button appears in full.
 - The controls will switch to baking mode.
 - All displays are active.
 - All buttons can be operated.
 - The oven will heat up.



NOTE!

The controls will automatically load the values set when they were last switched off. Provided no baking process has been started, the controls can be switched off.

Switching the controls OFF



1. Touch the STOP button.
The CANCEL menu will open.
2. Touch the ON / OFF button.
The controls will switch to OFF mode.

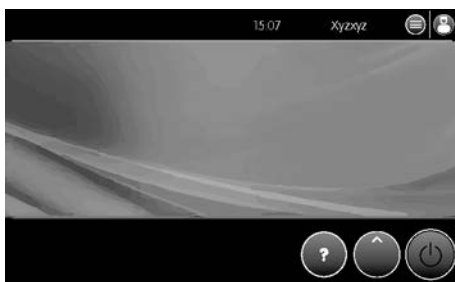
6.7. OFF mode

OFF mode means power supply ON and controls OFF.

- The operating unit is locked in OFF mode.
- Buttons are enabled by touching them until the illuminated circle around the button appears in full.



1. Switch the controls OFF.



HELP button
Menu with additional information about the current process.



ON / OFF button
Switching controls ON.
Activates the last mode selected.

6.8. AUTOMATIC MODE

Baking programs automate the baking process and ensure consistently high product quality. You can bake with baking programs as an Easy or Profi user. The following baking process is for Easy users.

Requirement:

- The controls are ON.
- There are no faults pending.

6.8.1. Selecting a baking program



1. Select the required baking program from the list.
 - The oven will start heating or cooling to the setpoint temperature.
2. Select the CONTINUE button.
3. Wait until ready to bake.
 - Do not load the oven yet.

6.8.2. Ready to bake

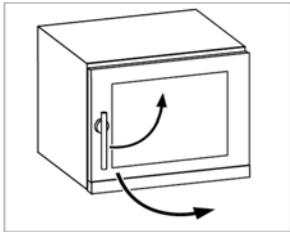
If the oven has reached the values set in the baking program, it is ready to bake.

'Ready to bake' is signalled as follows:

- A signal sounds.
- The temperature symbol flashes.
- Animation of loading the oven is shown.

6.8.3. OPEN / CLOSE baking chamber door

Opening the baking chamber door

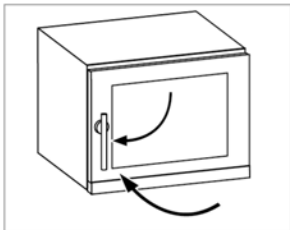


1. Open the baking chamber door.



The DOOR OPEN display will appear.

Closing the baking chamber door



1. Close the baking chamber door.
The DOOR OPEN display will go out.



NOTE!

If the DOOR OPEN display does not go out, the closing process must be repeated.
If the fault continues, contact MIWE service.

6.8.4. Loading the oven



NOTE!

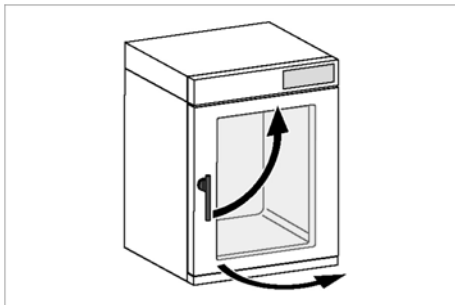
The first time the oven is heated each day, wait 10 to 15 minutes after 'ready to bake' before loading it.



1. The high temperatures inside the baking chamber pose a burn hazard.
 - When opening doors of the unit, ensure you are well away from the opening.
 - Keep the doors closed when the unit is unattended.



2. Wear the prescribed protective clothing for all work.



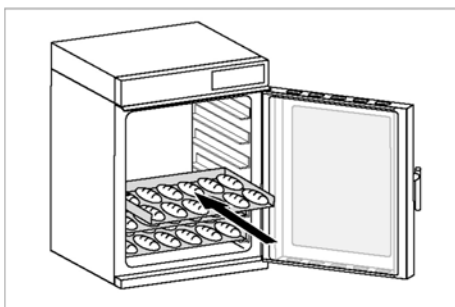
3. Open the baking chamber door. When you open the baking chamber door, the (optional) vapour hood fan automatically switches ON.



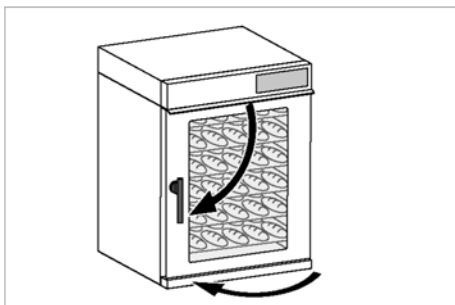
WARNING: SWARF IS A HEALTH RISK!

The baking trays and tray supports can rub against each other and produce swarf. Swarf is a health risk.

- Tilt the baking trays towards you slightly when sliding them in, and then lower onto supports.



4. Push in the loaded baking trays on the tray supports. Load the oven starting from the bottom.



5. Close the baking chamber door. The (optional) vapour hood fan switches OFF after 10 seconds.

6.8.5. Starting the baking process



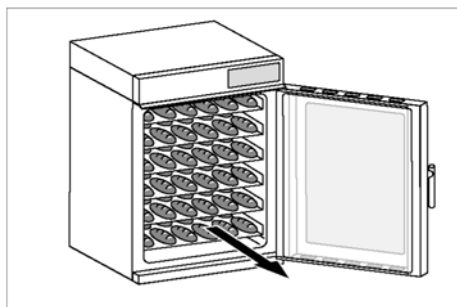
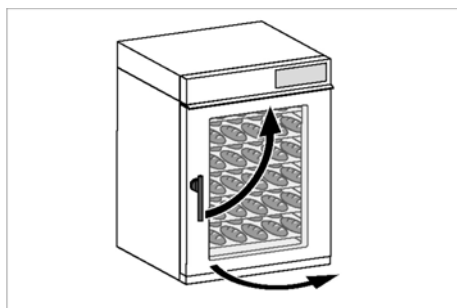
1. Touch the START button.
A prompt will appear.
2. Touch the CONFIRM button.
3. Wait for remaining baking time of 00:00:00 and end of baking signal.

6.8.6. Cancelling the baking process

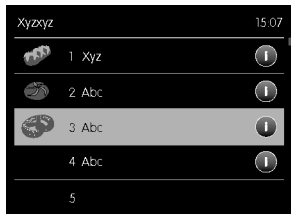
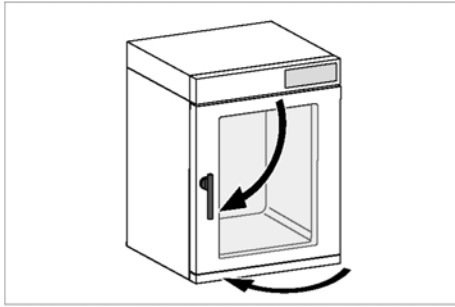


1. Touch the STOP button.
A sub-menu with cancellation options will open.
2. Touch the STOP button.

6.8.7. Unloading the oven



1. The high temperatures inside the baking chamber pose a burn hazard.
 - When opening doors of the unit, ensure you are well away from the opening.
 - Keep the doors closed when the unit is unattended.
2. Wear the prescribed protective clothing for all work.
3. Open the baking chamber door.
When you open the baking chamber door, the (optional) vapour hood fan automatically switches ON.
4. Remove the baking trays and place them on a heat-resistant surface.



5. Close the baking chamber door.
The (optional) vapour hood fan switches OFF after 10 seconds.

A list of baking programs will open.

6. Select a baking program and then start the next baking process.

or

6. Touch the STOP button and switch the oven to the following mode:
 - MIWE Eco-Modus
 - OFF mode

6.9. Managing baking programs

This menu allows you to create, change, copy, paste and delete baking programs.



1. As a Profi user, touch the MAIN MENU button.



The MAIN MENU will open.



2. Touch the PROGRAMS button in the SETTINGS section.



The MANAGE PROGRAMS menu will open.

Further information



1. Touch the HELP button.
A menu with additional information will open.

Each line can be used as the memory location for a new baking program.

The baking programs used can be saved under the program numbers 1 to 250 for direct selection.

The baking program currently selected is highlighted in yellow.

6.9.1. Creating and changing baking programs

There are two ways to create a new baking program:

- Selecting an empty memory location and creating a completely new baking program.
- Copying an existing baking program to an empty memory location, changing it and saving it under a new name.



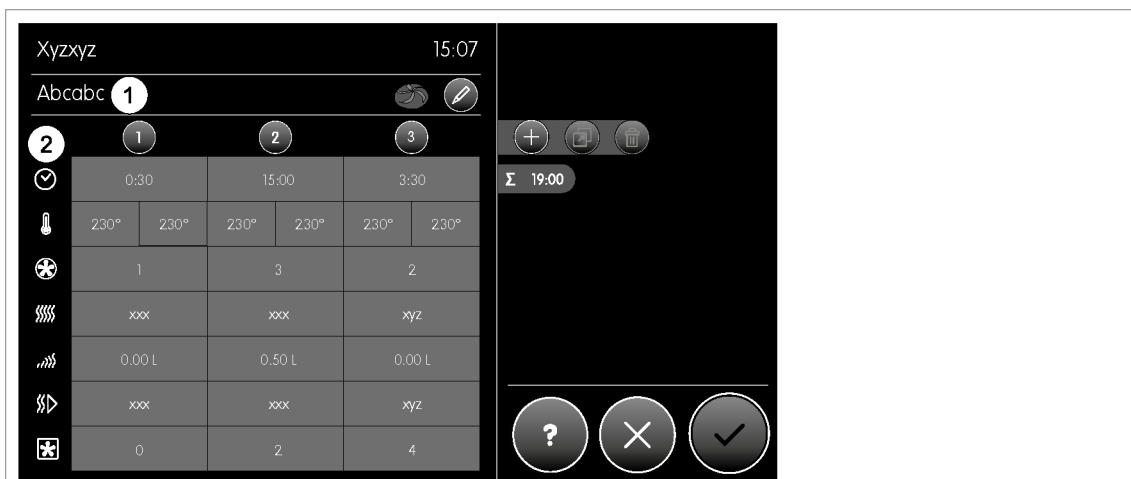
1. Touch the PROGRAMS button in the MAIN MENU. The MANAGE PROGRAMS menu will open.






















2. Touch the memory location of the baking program in the list.








3. Touch the CHANGE PROGRAM button. This will open the CHANGE PROGRAM menu.



Display Button	Explanation		
①	Display	Name of baking program	
	Button	Opens alphanumeric keypad for entering a name.	
②	Symbols for individual baking parameters		
		Duration of baking phase in minutes and seconds	
		Left	Setpoint temperature of baking chamber at start of baking phase.
		Right	Setpoint temperature of baking chamber at end of baking phase.
		Circulating fan setting 0 OFF 4 Maximum setting	
		Steam type	
		Normal	Steam input at the start of the baking phase
		Frozen dough	Even steam input throughout the entire baking phase
	Gastro	Even humidification during the baking phase	
	Steam quantity Normal and frozen dough steam type: Steam quantity setting in litres Gastro steam type: Humidity setting in %		
	Fresh air valve setting CLOSE No steam extraction D OPEN Steam extraction for baking chamber		
	Vapour hood fan setting 0 OFF 4 Maximum setting		
	The PRODUCT IMAGE button opens a menu. Touch the product image for the baking program. The product image is saved for the baking program.		

	<p>EDIT button Opens the EDIT PRODUCT menu.</p>	
		<p>The PRODUCT IMAGE button opens a menu. Touch the product image for the baking program. The product image is saved for the baking program.</p>
		<p>The PRODUCT NAME button opens an alphanumeric keypad for entering a name.</p>
		<p>The PRODUCT INFO button opens a menu for entering product information.</p>
		<p>FLEXBAKE button MIWE flexbake: capacity regulation Compensates for different baking conditions and loads.</p> <ul style="list-style-type: none"> • Partial loads • Baking temperatures • Baking chamber door opening times • Product temperature • Fluctuations in the power supply <p>The baking program must be saved once.</p>
  ...	<p>Display</p>	<p>List of possible baking phases.</p>
	<p>Button</p>	<p>Touching a digit activates the DUPLICATE and DELETE buttons.</p>
	<p>PASTE button</p> <p>Baking phase selected New baking phase is inserted after the selected phase</p> <p>No baking phase selected New baking phase is inserted at the end</p>	
	<p>DUPLICATE button</p> <p>Select baking phase and touch button. Duplicate baking phase is inserted after the selected phase. There is no prompt.</p>	
	<p>DELETE button</p> <p>Select baking phase and touch button. There is no prompt.</p>	
	<p>Total baking time in minutes and seconds.</p>	

	<p>HELP button Opens a menu with additional information.</p>	
	<p>Confirms values entered and returns to the MANAGE PROGRAMS menu.</p>	
	<p>CANCEL button Cancels action. A prompt appears before values or parameters are changed.</p>	
		<p>Back to CHANGE PROGRAM menu to save the changes.</p>
		<p>Discards changes.</p>

6.9.2. Copying and pasting baking programs

A baking program can be copied and pasted to a new position in the list so that it can then be changed and saved under a new name.



1. Touch the PROGRAMS button in the MAIN MENU.



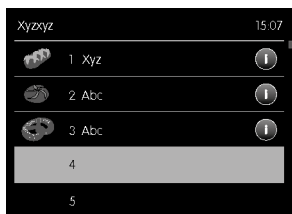
The MANAGE PROGRAMS menu will open.



2. Select a baking program.
Touch the memory location of the baking program in the list.



3. Touch the COPY button.
The baking program previously selected will be copied to the clipboard.



4. Touch a free memory location.



3

5. Touch the PASTE button.
A prompt will appear.



Cancels action.



The baking program is copied to the selected memory location.

6.9.3. Deleting baking programs

Baking programs which are no longer needed can be deleted from the list.



1. Touch the PROGRAMS button in the MAIN MENU.



The MANAGE PROGRAMS menu will open.



2. Select a baking program.
Touch the memory location of the baking program in the list.



3. Touch the DELETE button.
A prompt will appear.



Cancels action.



Deletes program.

6.10. Special functions

6.10.1. Recalibrating the screen

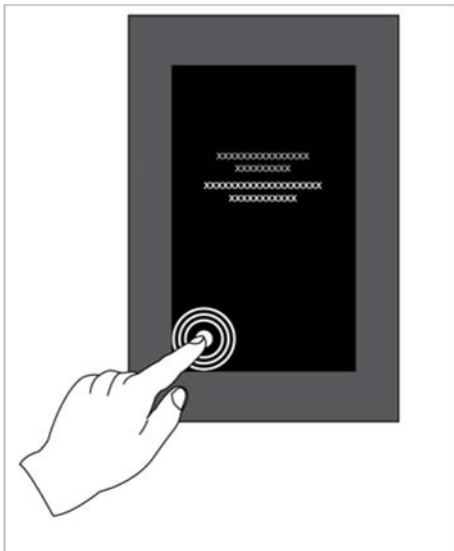
Switching the unit power OFF and ON again



1. Disconnect the unit power supply.
This can be done in various ways depending on the model:
 - Switch the master switch OFF.
 - Unplug the connector with earthing contact.
 - Switch off the mains circuit breaker.
2. Wait 10 seconds.
3. Switch unit back ON.

Calibration

4. The text "Screen calibration?" appears. While this text is shown, touch the screen once within 2 seconds.
5. The text "Touch crosshairs one by one" will then appear and the first crosshairs shown in the bottom left-hand corner.



6. Touch the centre of each of the five crosshairs that appear one after another.



NOTE!

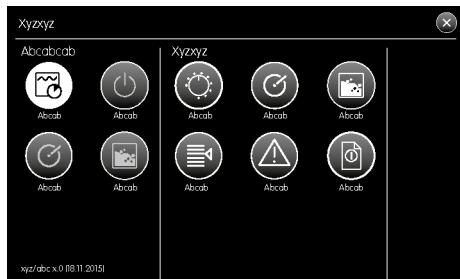
Touch the crosshairs for at least 1 second. If you only touch the crosshairs briefly, the screen will not be correctly calibrated and will not respond.

The controls will restart following successful calibration.

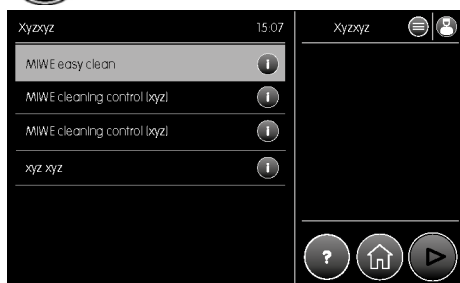
6.11. Cleaning programs



1. Touch the MAIN MENU button.



The MAIN MENU will open.



2. Touch the CLEAN button in the OPERATING MODES section.
The CLEANING PROGRAMS menu will open.

Further information



1. Touch the HELP button.
A menu with additional information will open.



NOTE!

For further information on using the cleaning programs, please see 'Cleaning programs' in 'Cleaning and care'.

7. Faults

This section sets out possible causes of faults and fault clearance options.

If faults occur with increasing frequency, shorten the maintenance intervals in line with actual use.

7.1. Safety information



RISK OF ELECTROCUTION!

Contact with live parts can kill. Damage to the insulation or individual components can cause death.

- Always have work on electrical equipment carried out by qualified electricians.
- Before any work, switch off the power supply to the unit and make sure it cannot be switched back on.

For further information, please see 'Safety devices' – 'Power supply'.

- Protect live parts from moisture.
Moisture can cause electric shocks and short-circuiting.
- Have damaged insulation repaired.
- Never bypass or disable safety devices such as fuses or safety thermostats.
- Observe the correct amperage and characteristics when replacing fuses.
- If the unit is to be disconnected from the power supply, unplug the connector.



HOT SURFACES CAN CAUSE INJURY!

Touching hot surfaces can result in serious injury.

- Allow the unit to cool down to ambient temperature.
- Wear the prescribed protective clothing for all work.



RISK OF FALLING!

A fall from a unit can cause serious injury.

In accordance with health and safety regulations, anyone working at a height of 1.50 m or more must use the appropriate, approved equipment.

- Sturdy ladder
- Scaffolding
- Lifting platform

The owner-operator must provide this equipment and comply with official industry association health and safety regulations.

**CAUTION: INCORRECT FAULT CLEARANCE CAN CAUSE INJURY!**

Incorrect fault clearance can result in serious injury and damage.

- Before any work, switch off the power supply to the unit and make sure it cannot be switched back on.
For further information, please see 'Safety devices' – 'Power supply'.
- Allow the unit to cool down to ambient temperature.
- Before starting any work, make sure there is sufficient space for installation and assembly.
- Make sure the work area is sufficiently well lit.
- Make sure that the work area is clean and tidy.
Loosely piling components and tools or leaving them lying around can cause accidents.
- Ensure correct assembly/installation.
Refit all fastening elements and apply the correct screw tightening torques.
- Close off the workspace to unauthorised persons.

Personnel

- The work described here for fault clearance can be carried out by the operator unless otherwise indicated.
- Certain jobs may only be carried out by specially trained qualified personnel or only by the manufacturer. This is indicated in the description of the faults in question.
- Always have work on electrical equipment carried out by qualified electricians.

Qualified electrician

A qualified electrician has the technical training, expertise and experience necessary to assess and carry out all electrical work assigned to them and to recognise potential hazards.

The above person(s) must be familiar with/able to:

- Install low-voltage systems.
- Operate electrical systems.
- Machine safety.
- Electrical safety devices.
- Human-machine interfaces.
- Install stationary electrical facilities.
- Lay and connect electrical lines and connections.
- Fit distributors, residual current devices, switches, push buttons and sockets.
- Measure the effectiveness of electrical safety devices.



IMPORTANT NOTE ON ELECTRICAL SYSTEMS IN GERMANY

The qualified electrician must be registered in the network operator's register of installation engineers [*Installateurverzeichnis*]. Qualified electricians receive training on the latest standards, legislation and technical developments at least once a year.

Qualified electricians have a duty to observe the following national and regional laws and regulations:

- Accident prevention regulations - for Germany, DGUV Vorschrift 3 (previously BGV A3)

7.2. What to do in the event of a fault



1. Identify possible cause.
2. If clearing the fault requires work in the hazard zone, switch off the power supply to the unit and make sure it cannot be switched back on.
For further information, please see 'Safety devices' – 'Power supply'.
3. Inform the competent person at the site about the fault.
4. Arrange for MIWE service to deal with the fault or deal with it yourself as appropriate.



NOTE!

If the fault continues, contact MIWE service.

7.3. Electrical and mechanical faults

Possible cause	Fault clearance
Unit power off upon start-up	
Power supply interrupted.	<p>By owner-operator</p> <ul style="list-style-type: none"> Actuate the safety temperature limiter (see 'Actuating the safety temperature limiter').
Unit cannot be switched on	
Power supply interrupted during operation.	<p>By owner-operator</p> <ul style="list-style-type: none"> Check that the unit is properly connected to the power supply (visual check). Switch the unit back on.
<p>The safety temperature limiter has tripped.</p> <ul style="list-style-type: none"> Heating OFF. Operating unit ON. 	<p>By owner-operator</p> <ul style="list-style-type: none"> Actuate the safety temperature limiter (see 'Actuating the safety temperature limiter').
Screen does not respond.	<p>By owner-operator</p> <ul style="list-style-type: none"> Recalibrate the screen. (See 'Recalibrating the screen' in 'Operation - Special functions'.)
The DOOR OPEN display is on although the baking chamber door is closed.	<p>By owner-operator</p> <ul style="list-style-type: none"> Open and close the baking chamber door.

Circulating fan does not start up within 15 seconds of baking chamber door being closed

<p>The thermal protection switch in the circulating motor has cut out.</p>	<p>Automatic</p> <ul style="list-style-type: none"> Thermal protection switch closes automatically once the overheated circulating motors have cooled down.
<p>Operating unit, circulating motor or contactor is defective.</p>	<p>By MIWE service</p>
<p>DOOR OPEN symbol lit up.</p>	<p>By owner-operator</p> <ul style="list-style-type: none"> Open and close the baking chamber door.

Baking chamber lighting is not working – halogen lighting

<p>Lamp is defective.</p>	<p>By owner-operator</p> <ul style="list-style-type: none"> Replace the lamp (see 'Replacing lamps' in 'Inspection and maintenance').
---------------------------	---

Baking chamber lighting is not working – LED lighting

<p>Lamp is defective.</p>	<p>By MIWE service</p>
---------------------------	-------------------------------

Uneven results	
Air deflectors incorrectly set.	By MIWE service
Heating defective.	By MIWE service
Fresh air valve defective.	By MIWE service
Wrong baking program	By owner-operator <ul style="list-style-type: none"> • Check and change the baking program as necessary (see 'Operation', 'Managing baking programs').
Steam input is not working / not working properly	
Water supply line faulty.	By owner-operator <ul style="list-style-type: none"> • Check water supply line for leaks.
Water supply line closed.	By owner-operator <ul style="list-style-type: none"> • Open the water supply line.
Fine filter in connection piece dirty.	By owner-operator <ul style="list-style-type: none"> • Clean the fine filter in the connection piece (see 'Inspection and maintenance', 'Cleaning the filter in the water system connection piece').
Water supply too low.	By MIWE service

Solenoid valve defective.	By MIWE service
Steam device dirty / scaled up.	By MIWE service
Drinking water canister empty. (Version with water tank system)	By owner-operator <ul style="list-style-type: none"> • Fill drinking water canister (see 'Cleaning and care', 'Water tank system').
MIWE easy clean not working	
Water supply line faulty.	By owner-operator <ul style="list-style-type: none"> • Check water supply line for leaks.
Water supply line closed.	By owner-operator <ul style="list-style-type: none"> • Open the water supply line.

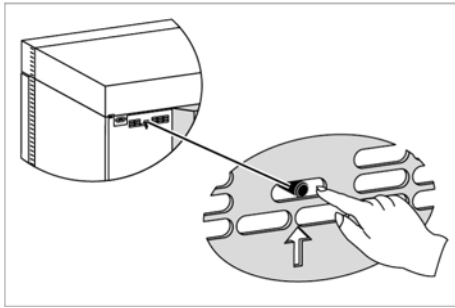
Cleaning with MIWE cleaning control (optional) has not produced satisfactory results

<p>Cleaning cycle has run without cleaning agent.</p>	<p>By owner-operator</p> <ul style="list-style-type: none"> • Top up cleaning agent. (See 'Filling up the cleaning agent' in 'Cleaning and care'.)
<p>Water supply line closed.</p>	<p>By owner-operator</p> <ul style="list-style-type: none"> • Open the water supply line.
<p>Water pressure too low.</p>	<p>By owner-operator</p> <ul style="list-style-type: none"> • Check that the flow pressure is at least 2 bar.
<p>Spray nozzle dirty. Spray nozzle will not rotate or jams.</p>	<p>By owner-operator</p> <ul style="list-style-type: none"> • Check spray nozzle (see 'Checking the spray nozzle function')
<p>Spray nozzle scaled up.</p>	<p>By owner-operator</p> <ul style="list-style-type: none"> • Check spray nozzle (see 'Checking the spray nozzle function') • Check water filter (optional). Replace if necessary.
<p>Water filter needs replacing.</p>	<p>By owner-operator</p> <ul style="list-style-type: none"> • Change the water filter.

Cleaning agent is washed into the baking chamber when cleaning is not in progress

<p>Relay defective.</p>	<p>By MIWE service</p> <p>By owner-operator</p> <ul style="list-style-type: none"> • Dispose of products (safety).
-------------------------	---

7.3.1. Actuating the safety temperature limiter



1. Press the safety temperature limiter a maximum of twice.
If the fault continues, contact MIWE service.

7.4. Fault messages with fault codes – TC controls

If a fault occurs, a signal sounds. The corresponding fault message is displayed. This provides information on the cause of the fault and fault clearance.

Faults must be acknowledged with the ACKNOWLEDGE button.
For further information, please see 'Fault messages'.

8. Cleaning and care

8.1. Safety information

For hygiene and health reasons, the unit must be carefully cleaned every day.



RISK OF ELECTROCUTION!

Contact with live parts can kill. Damage to the insulation or individual components can cause death.

- Always have work on electrical equipment carried out by qualified electricians.
- Before any work, switch off the power supply to the unit and make sure it cannot be switched back on.

For further information, please see 'Safety devices' – 'Power supply'.

- Protect live parts from moisture.
Moisture can cause electric shocks and short-circuiting.
- Have damaged insulation repaired.
- Never bypass or disable safety devices such as fuses or safety thermostats.
- Observe the correct amperage and characteristics when replacing fuses.
- If the unit is to be disconnected from the power supply, unplug the connector.



HOT SURFACES CAN CAUSE INJURY!

Touching hot surfaces can result in serious injury.

- Allow the unit to cool down to ambient temperature.
- Wear the prescribed protective clothing for all work.



RISK OF FALLING!

A fall from a unit can cause serious injury.

In accordance with health and safety regulations, anyone working at a height of 1.50 m or more must use the appropriate, approved equipment.

- Sturdy ladder
- Scaffolding
- Lifting platform

The owner-operator must provide this equipment and comply with official industry association health and safety regulations.



CAUTION: EDGES AND CORNERS CAN CAUSE INJURY!

Sharp edges and corners can cause cuts and grazes.

- Always be careful when working at components with sharp edges or corners.
- Wear the prescribed protective clothing for all work.

8.2. Cleaning schedule

Cleaning	Section in documentation	Intervals (1-shift operation)	Intervals (3-shift operation)
Housing	x	Daily	Daily
Operating unit			
Baking chamber			
Glass panel			
Door seal			
Tray supports			
Baking trays			
Collection channel for baking residue			
Water tank system (optional)			
Vents			
Baking chamber with MIWE cleaning control cleaning program	x	Automatic cleaning at selected intervals possible. MIWE recommends running the cleaning program 2x weekly.	



SERVICE INFORMATION

If the baking chamber is extremely dirty, it may need to be cleaned further by hand as well as with the MIWE cleaning control automatic cleaning program.

8.3. Cleaning



CAUTION: INCORRECT CLEANING CAN CAUSE DAMAGE!

Cleaning the unit incorrectly can damage it.

- Never clean the unit with a pressure hose.
- Do not use abrasive cleaning agents or scourers.
- Never use steel wool or any other sharp-edged cleaning materials.
- Only ever clean the unit with a soft, slightly damp cloth.
- Follow the specific instructions of the manufacturer for all cleaning agents and equipment.

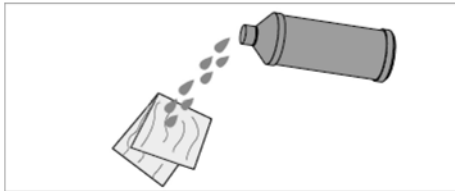


CAUTION: DIRTY SERVICE FLUIDS AND EQUIPMENT ARE A HEALTH RISK!

Areas that come into direct contact with food are subject to strict hygiene requirements. Dirty service fluids or equipment encourage the growth and development of harmful microorganisms. Inhaling and digesting these organisms can be injurious to health.

- Use separate, clean service fluids and equipment for food systems.

8.3.1. Casing



1. Switch off the power supply to the unit and make sure it cannot be switched back on.
Allow the unit to cool down to ambient temperature.
2. Wear the prescribed protective clothing for all work.
3. Clean the casing as required with a soft, slightly damp cloth. If extremely dirty, also use a non-abrasive, sand-free cleaning agent.
Rinse thoroughly after cleaning to ensure no cleaning agent residue remains.



NOTE!

Clean the casing with coloured surface (optional) as required with a soft, slightly damp cloth. If it is extremely dirty, you can also use spirits.



CAUTION: OVERLOADING CAN DAMAGE THE OVEN TOP AND VAPOUR HOOD!

Placing heavy loads on the oven can damage the top of the oven and the vapour hood.

- Do not stand on them to clean.
- Maximum load 50 kg/m².

8.3.2. Operating unit



CAUTION: CLEANING AGENT CAN CAUSE DAMAGE!

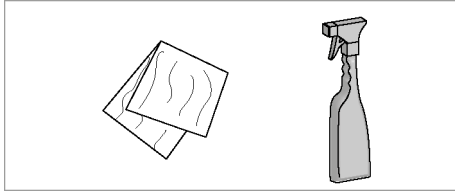
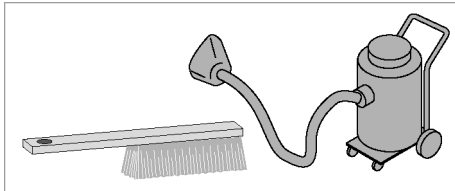
Cleaning agent can damage the operating unit.

- Only ever clean with water.



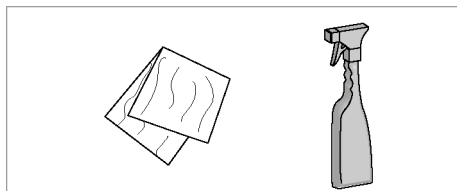
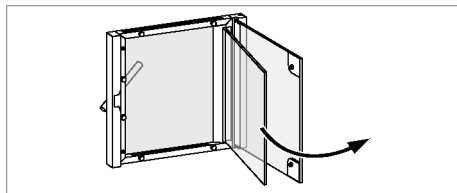
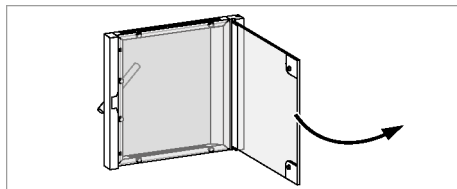
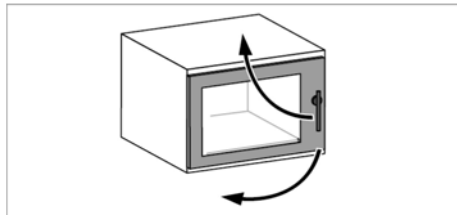
1. Switch off the power supply to the unit and make sure it cannot be switched back on.
Allow the unit to cool down to ambient temperature.
2. Wear the prescribed protective clothing for all work.
3. Clean the operating unit as required with a soft, slightly damp cloth.

8.3.3. Baking chamber



1. Switch off the power supply to the unit and make sure it cannot be switched back on.
Allow the unit to cool down to ambient temperature.
2. Wear the prescribed protective clothing for all work.
3. Remove crumbs etc. from the baking chamber using a suitable brush or a vacuum cleaner.
4. Clean the baking chamber as required with a soft, slightly damp cloth. If extremely dirty, also use a non-abrasive, sand-free cleaning agent. Rinse thoroughly after cleaning to ensure no cleaning agent residue remains.

8.3.4. Glass panel



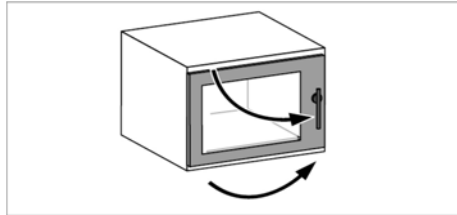
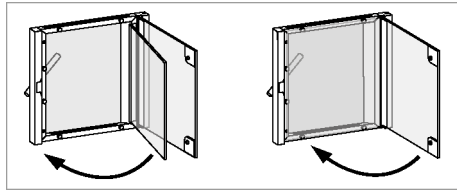
1. Switch off the power supply to the unit and make sure it cannot be switched back on.
Allow the unit to cool down to ambient temperature. When closing the doors, ensure you are well away from the opening.
2. Wear the prescribed protective clothing for all work.
3. Open the baking chamber door.
4. Open the inside glass panel into the baking chamber.
5. Open the (optional) middle glass panel into the baking chamber.
6. Clean the glass panels as required with a soft, slightly damp cloth. If extremely dirty, also use a non-abrasive, sand-free cleaning agent. Rinse thoroughly after cleaning to ensure no cleaning agent residue remains.



CAUTION: INSIDE PANEL MAY BREAK!

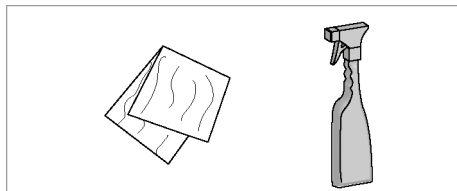
The inside glass panel can be irreparably damaged when the baking chamber door is closed.

- Close the inside panel before closing the baking chamber door.



7. Close the (optional) middle panel first and then the inside panel.
The magnets pose a crush hazard when the glass panels are being closed. Close panel carefully.
8. Close the baking chamber door.

8.3.5. Door seal



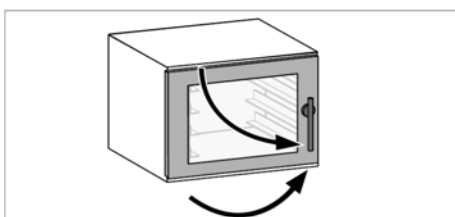
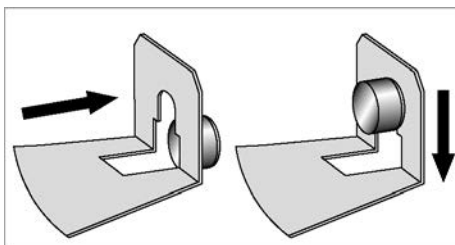
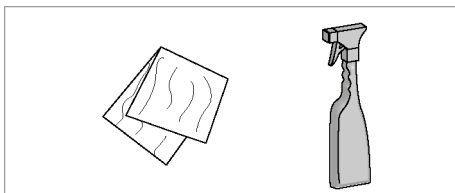
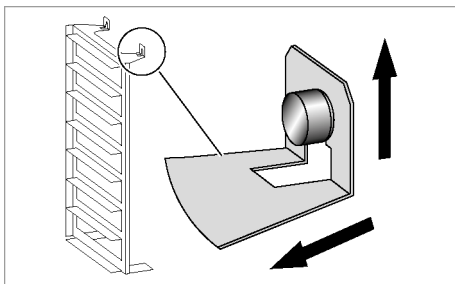
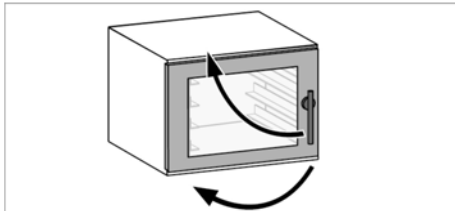
1. Switch off the power supply to the unit and make sure it cannot be switched back on.
Allow the unit to cool down to ambient temperature.
2. Wear the prescribed protective clothing for all work.
3. Open the door.
4. Clean the door seal as required with a soft, slightly damp cloth. If extremely dirty, also use a non-abrasive, sand-free cleaning agent.
Rinse thoroughly after cleaning to ensure no cleaning agent residue remains.
5. Close the door.



NOTE!

To prevent premature wear, the manufacturer recommends rubbing the door seal after cleaning with standard, food-safe talcum powder.

8.3.6. Tray supports



1. Switch off the power supply to the unit and make sure it cannot be switched back on. Allow the unit to cool down to ambient temperature.
2. Wear the prescribed protective clothing for all work.
3. Open the baking chamber door.
4. Lift the tray supports up and over the fastening bolts, towards the middle and out.
5. Clean the tray supports as required with a soft, slightly damp cloth. If extremely dirty, also use a non-abrasive, sand-free cleaning agent. Rinse thoroughly after cleaning to ensure no cleaning agent residue remains.
6. Push the tray supports over the fastening bolts and into place.
7. Close the baking chamber door.

8.3.7. Baking trays



CAUTION: DAMAGE TO BAKING TRAYS WITH NON-STICK COATING!

Incorrect use can cause damage to the coating.

- Do not use at temperatures in excess of 270 C.
- Avoid flour dust on silicone-coated baking trays.
- Do not use cleaning agents.
- Do not clean in tray washer, dishwasher or by the self-cleaning mode of the oven.



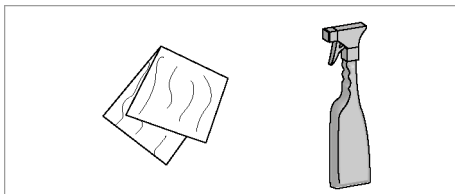
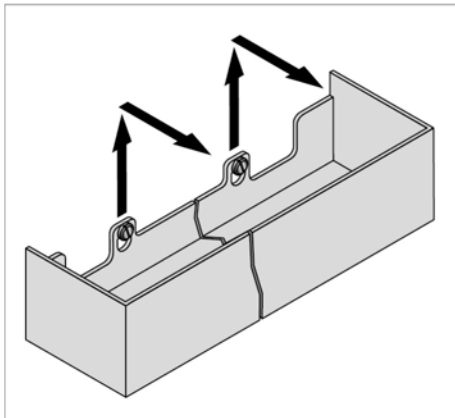
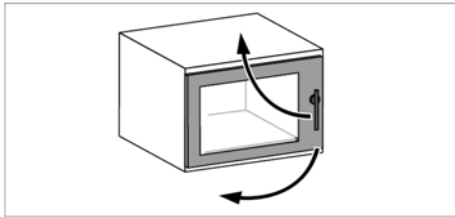
NOTE!

- Immediately replace baking trays with damaged coating.
- Do not use sharp or pointed objects.
- Store baking trays such that they cannot be damaged.
- Clean the non-coated aluminium baking trays following the manufacturer's instructions.

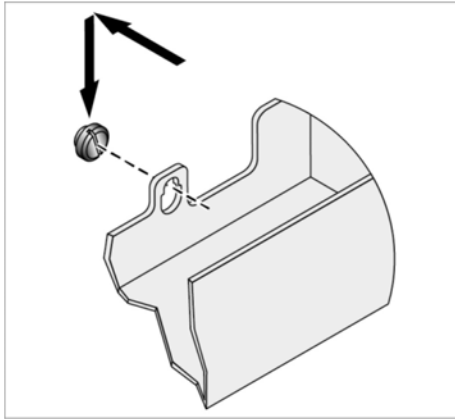
Non-coated	Coated
<ul style="list-style-type: none"> • Prior to the first baking process, clean in soapy water at at least 60 C and dry. Lubricant residues are removed. 	<ul style="list-style-type: none"> • Prior to the first baking process, clean in hot water and dry.
<ul style="list-style-type: none"> • After baking, clean the baking trays as required with a soft, slightly damp cloth. If extremely dirty, also use a non-abrasive, sand-free cleaning agent. • Rinse thoroughly after cleaning to ensure no cleaning agent residue remains. 	<ul style="list-style-type: none"> • After baking, clean the baking trays as required with a soft, slightly damp cloth.
<ul style="list-style-type: none"> • Grease to prevent rusting (except for aluminium trays). 	<ul style="list-style-type: none"> • Do not grease.

8.3.8. Collection channel for baking residue

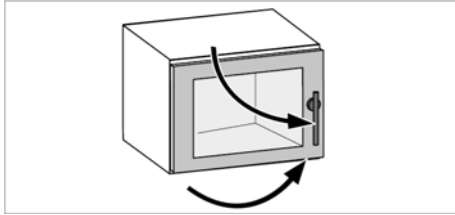
There is a detachable collection channel below the baking chamber door.



1. Switch off the power supply to the unit and make sure it cannot be switched back on.
Allow the unit to cool down to ambient temperature.
2. Wear the prescribed protective clothing for all work.
3. Open the baking chamber door.
4. Lift the collection channel up and out the front over the fastening bolt.
5. Clean the collection channel as required with a soft, slightly damp cloth. If extremely dirty, also use a non-abrasive, sand-free cleaning agent. Rinse thoroughly after cleaning to ensure no cleaning agent residue remains.



6. Push the collection channel over the fastening bolts and into place.



7. Close the baking chamber door.

8.3.9. Water tank system

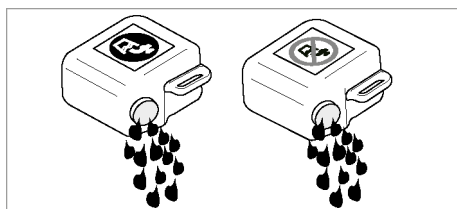
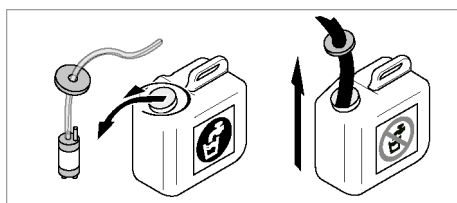
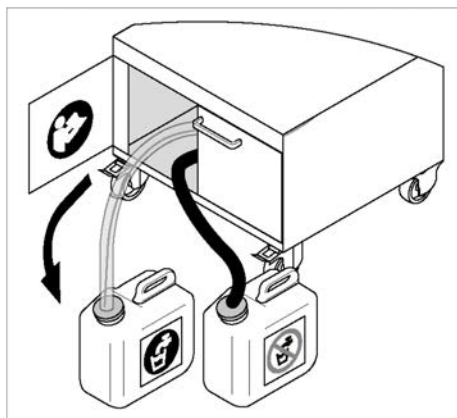


WARNING: DIRTY WATER IS A HEALTH RISK!

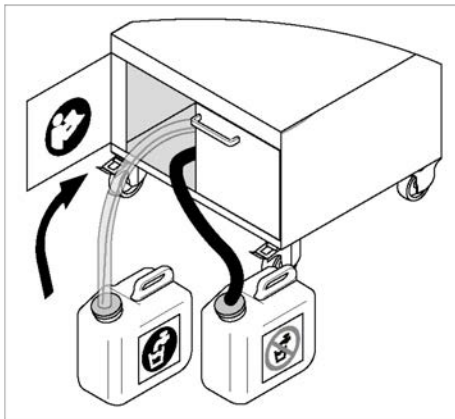
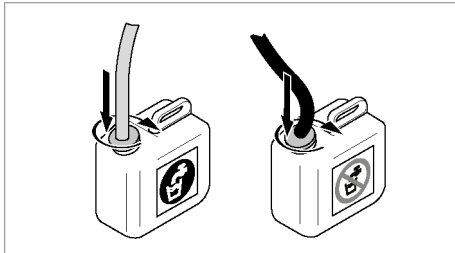
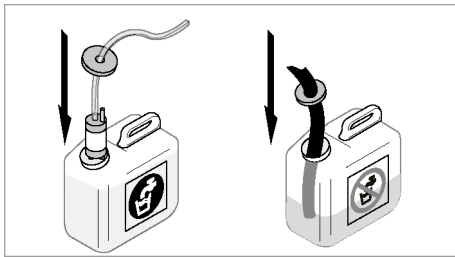
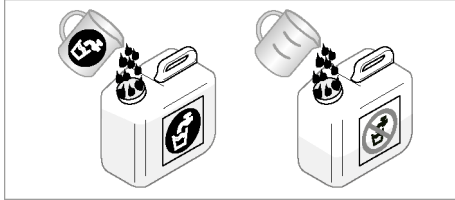
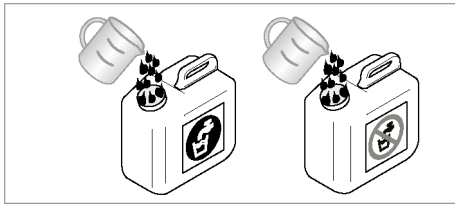
Dirty water encourages the growth and development of harmful microorganisms. Inhaling and ingesting these organisms can damage your health.

- Empty and clean the drinking water and wastewater canisters every day.
- Always rinse out the drinking water and wastewater canisters with hot water before you refill them.
- If the water tank system has not been in use for over a week, rinse the water supply hose before use.

Drinking water and wastewater canister



1. Switch off the power supply to the unit and make sure it cannot be switched back on.
Allow the unit to cool down to ambient temperature.
2. Wear the prescribed protective clothing for all work.
3. Carefully remove the two canisters from the base frame.
Be careful with the cables and hoses.
4. Unscrew the cover.
5. Remove the submersible pump from the drinking water canister and place it on a clean surface.
6. Remove the water drainage hose from the wastewater canister.
7. Empty the drinking water and wastewater canisters.



8. Rinse out the drinking and wastewater canisters with hot water.
9. Fill the drinking water canister with cold drinking water.
10. Fill the wastewater canister up to c. 3-4 cm with water.
11. Place the submersible pump in the drinking water canister.
12. Put the water drainage hose in the wastewater canister, making sure that the end of the hose is under water.
Make sure that the right hose is connected to the right canister.
13. Replace and screw on both covers.
14. Replace the two canisters in the base frame.
Be careful with the cables and hoses.

Rinsing out the water supply hose



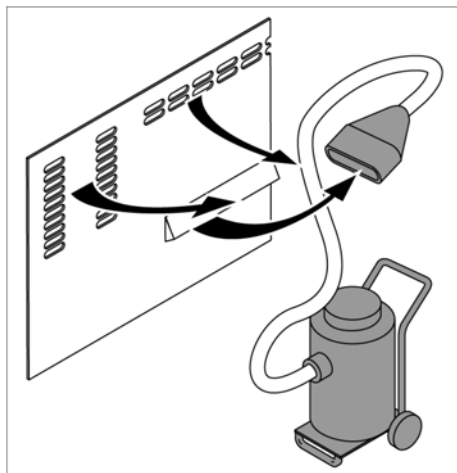
1. Select a baking program with steam input.
2. Wait until ready to bake.
3. Start the baking program.
The water supply hose will be rinsed out.
4. Stop the baking program after c. 60 seconds.
Repeat until a total of 800–1000 ml steam has been input.

8.3.10. Vents

Dust can collect on the vents.



1. Switch off the power supply to the unit and make sure it cannot be switched back on.
Allow the unit to cool down to ambient temperature.
2. Wear the prescribed protective clothing for all work.
3. Only ever vacuum the vents.



8.4. Cleaning programs for the baking chamber

An automatic cleaning program can be used to clean the baking chamber including tray supports, suction plate and baking chamber drain.

Please note the following information for the:

- MIWE cleaning control fully automatic cleaning program.
For further information, please see 'MIWE cleaning control cleaning program'.
- MIWE easy clean semi-automatic cleaning program.
For further information, please see 'MIWE easy clean cleaning program'.

The cleaning programs start when the baking chamber door is closed and the water feed line open.

8.4.1. Safety information



WARNING: INCORRECT USE OF THE CLEANING PROGRAM CAN RESULT IN INJURY!

Incorrect use of the cleaning program can result in serious accidents and health risks.

- Remove the baking trays from the baking chamber before starting the cleaning program.
- Ensure before starting the cleaning program that there are no foreign objects or persons or animals inside the baking chamber.
- Ensure that the unit is not moved whilst the cleaning program is running.

WARNING: INSUFFICIENT WATER FOR THE CLEANING PROGRAM CAN CAUSE DAMAGE!

The cleaning program will not function properly if the water supply line is closed while the cleaning program is running.

- Never cut off the water supply line while the cleaning program is running.



NOTE FOR MULTIPLE BAKING CHAMBERS!

Cleaning is only possible if none of the baking chambers are in use.

8.4.2. Checking the spray nozzle function

Check the spray nozzle is functioning correctly before starting the cleaning program.

The spray nozzle rotor must turn easily.

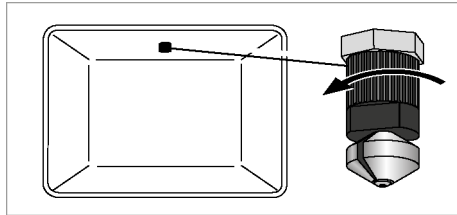
Clean the spray nozzle if this is not the case.



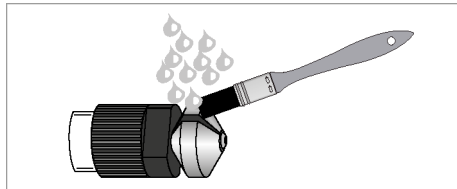
WARNING: USING TOOLS TO SCREW ON THE SPRAY NOZZLE CAN CAUSE DAMAGE!

Tools can damage the spray nozzle and its bracket, rendering it unfit for use.

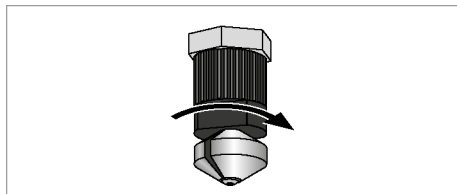
- Never use tools to screw on the spray nozzle.



1. Unscrew the spray nozzle (anticlockwise).



2. Clean the spray nozzle with a soft brush and running water.



3. Screw on the spray nozzle by hand (clockwise)



NOTE!

The best cleaning results are only achieved with a spray nozzle.

The cleaner is only rinsed out completely if the spray nozzle is correctly attached and working properly.

8.4.3. Checking the door seal



WARNING: LEAKING LIQUIDS CAN CAUSE INJURY!

If the door seal is damaged, liquids may leak out during the cleaning process.

- Check the door seal before each cleaning cycle.



1. Check the door seal for damage such as cracks.
Change the door seal if necessary.
For further information, please see 'Inspection and maintenance', 'Maintenance work', 'Changing the door seal'.
2. Check the position of the collection channel to ensure any liquid that leaks is collected.
3. Remove the worst of the dirt from the door seal.

8.4.4. Check at the end of the cleaning program

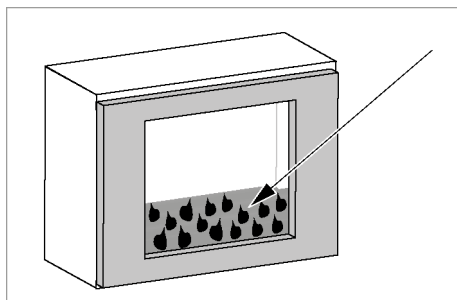
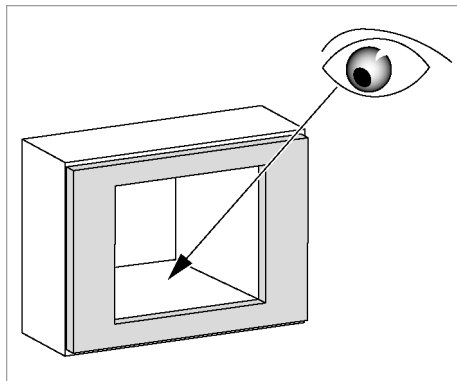


WARNING: LEAKING LIQUIDS CAN CAUSE INJURY AND DAMAGE!

If the baking chamber door is unlocked and opened before all hot liquid has drained from the baking chamber, liquid may escape and cause scalding.

- Visual inspection.

Carrying out a visual inspection



1. Look to see whether there is any liquid left in the baking chamber.
2. Do not open the baking chamber door if there is liquid left in the baking chamber.
Contact MIWE service.

8.5. MIWE cleaning control cleaning program

MIWE cleaning control is a fully automatic program for cleaning the baking chamber. It does not require any manual operations by the operator.

- The program cleans the baking chamber with liquid cleaner.
- The cleaning program can be started automatically at set times.
- The cleaning program must be operated with a water treatment system.

8.5.1. Safety information



CAUTION: USING THE WRONG CLEANING AGENT CAN CAUSE DAMAGE!

Using a cleaning agent other than that specified by MIWE can cause material damage.

- Only use the specified cleaning agent.



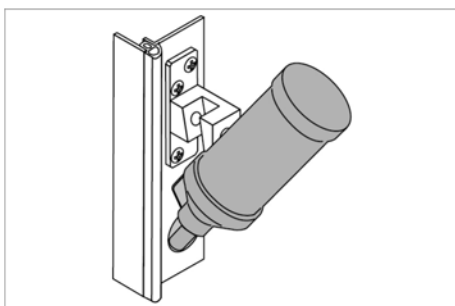
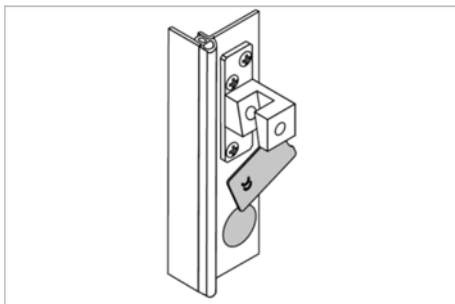
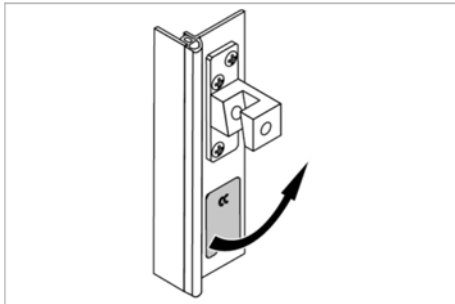
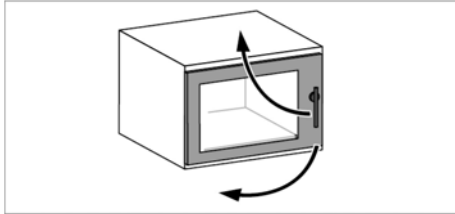
WARNING: OBSERVE THE INFORMATION ON THE SAFETY DATA SHEET!

Access the relevant safety data sheet from the MIWE homepage.

- Go to www.miwe.com / Service / Sicherheitsdatenblätter.
- Enter the item number.
For further information, please see 'Wear and spare parts list'.
- Select country of use.

8.5.2. Filling up the cleaning agent

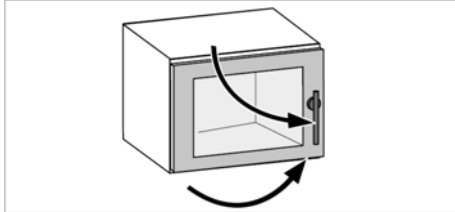
If the cleaner tank is empty, a fault message will appear.



1. Acknowledge the fault message.
2. Open the baking chamber door.
2. Unscrew the protective cap on the bottle of cleaner. There is a film in the neck of the bottle to prevent the cleaner leaking out.
3. Open the cover on the filling opening.
4. Push the bottle into the opening. The film on the cleaner bottle is pierced when pushed into the filling opening.
5. Empty the bottle completely. Maximum refill 4 litres.



6. Unscrew the protective cap and dispose of the bottle.



7. Close the baking chamber door.

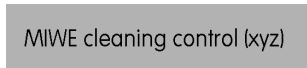
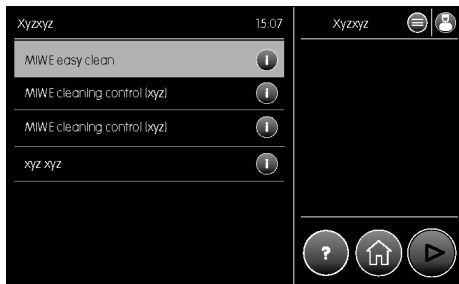
8.5.3. Running a cleaning program

Requirement

- The unit is connected to the power supply.
- Water supply open.
- Spray nozzle function checked.

For further information, please see 'Checking the spray nozzle function' in the section on cleaning programs for the baking chamber.

Starting the cleaning program manually



1. Close the baking chamber door.
2. Touch the MAIN MENU button.
3. The main menu will open.

4. Touch the CLEAN button in the OPERATING MODES section.

The CLEANING PROGRAMS menu will open.

5. Touch the MIWE cleaning control (rapid) or MIWE cleaning control (intensive) button and select the level of dirt
 Rapid = slightly dirty
 Intensive = extremely dirty
6. Touch the START button.
 A prompt will appear.
7. Touch the CONFIRM button.

Canceling the cleaning program



1. Touch the STOP button.
A prompt will appear.



2. Touch the CONFIRM button.
 - The cleaning program will stop immediately.
 - The cancellation program will start. Duration depends on how far on the cleaning program is.
 - The program rinses out the baking chamber thoroughly with water to remove all residue.



NOTE!

The cleaning program can be cancelled at any time.
This function should, however, only be used when absolutely necessary.

Any phase which has begun will first finish (depends how far the cleaning program is).

Check at end of program



1. Look to see whether there is still any liquid left in the baking chamber.
For further information, please see "Checking the baking chamber at the end of the program".

At the end of the cleaning program:

- The controls switch to OFF mode.
- The controls switch to AUTOSTART if selected.

9. Inspection and maintenance

Certain maintenance work must be left strictly to MIWE service or an authorised partner of MIWE service. This is highlighted in the maintenance schedule.

Nevertheless, the owner-operator can help to prevent damage to the unit by carrying out regular visual checks of the relevant components.



WARRANTY

In the interests of machine safety, MIWE requires that only MIWE spare parts be used. The warranty is only valid if original MIWE spares are used.

MIWE spare parts can be obtained from authorised dealers or directly from the manufacturer.

9.1. Safety information



RISK OF ELECTROCUTION!

Contact with live parts can kill. Damage to the insulation or individual components can cause death.

- Always have work on electrical equipment carried out by qualified electricians.
- Before any work, switch off the power supply to the unit and make sure it cannot be switched back on.

For further information, please see 'Safety devices' – 'Power supply'.

- Protect live parts from moisture.
Moisture can cause electric shocks and short-circuiting.
- Have damaged insulation repaired.
- Never bypass or disable safety devices such as fuses or safety thermostats.
- Observe the correct amperage and characteristics when replacing fuses.
- If the unit is to be disconnected from the power supply, unplug the connector.



HOT SURFACES CAN CAUSE INJURY!

Touching hot surfaces can result in serious injury.

- Allow the unit to cool down to ambient temperature.
- Wear the prescribed protective clothing for all work.

**INCORRECT MAINTENANCE CAN CAUSE INJURY!**

Incorrect maintenance can lead to serious injury and damage.

- Before any work, switch off the power supply to the unit and make sure it cannot be switched back on.
For further information, please see 'Safety devices' – 'Power supply'.
- Before starting any work, make sure there is sufficient space for installation and assembly.
- Make sure the work area is sufficiently well lit.
- Make sure that the work area is clean and tidy.
Loosely piling components and tools or leaving them lying around can cause accidents.
- Ensure correct assembly/installation.
Refit all fastening elements and apply the correct screw tightening torques.
- Close off the workspace to unauthorised persons.

**RISK OF FALLING!**

A fall from a unit can cause serious injury.

In accordance with health and safety regulations, anyone working at a height of 1.50 m or more must use the appropriate, approved equipment.

- Sturdy ladder
- Scaffolding
- Lifting platform

The owner-operator must provide this equipment and comply with official industry association health and safety regulations.

**CAUTION: EDGES AND CORNERS CAN CAUSE INJURY!**

Sharp edges and corners can cause cuts and grazes.

- Always be careful when working at components with sharp edges or corners.
- Wear the prescribed protective clothing for all work.

9.2. Maintenance schedule

The maintenance intervals given here are the minimum frequency required for smooth and satisfactory operation.



MAINTENANCE INSTRUCTIONS

- The owner-operator must ensure daily visual inspections of the unit.
- If there is significant wear, the necessary maintenance intervals must be shortened in accordance with the actual wear.

9.2.1. Maintenance by the owner-operator



CAUTION: DISREGARDING MAINTENANCE INTERVALS CAN LEAD TO DAMAGE!

Disregarding maintenance intervals can lead to damage to the unit and disrupt processes.

- Adhere to the specified maintenance intervals.



SERVICE INFORMATION

To ensure the safety and operation of the product, the manufacturer requires complete servicing by MIWE once a year.

Maintenance work	Section in documentation	Intervals (1-shift operation)	Intervals (3-shift operation)
Check the water treatment system	-	Weekly	Every 4 days
Clean the siphon	x	Monthly	Weekly
Rinse the water drainage hoses			
Check door seal and replace if worn			
Visual inspection of water system; change hoses if worn or leaky	-		
Clean filter in connection piece	x	Once a quarter	Monthly
Check silicone and stop buffers and magnets on the outside and inside panels and replace if worn			
Change the lamps	x	As required	As required
Inspection by MIWE service	-	Every 6-12 months	Every 2-4 months

9.2.2. Maintenance/service by MIWE service

MIWE carries out a range of work as per the inspection plan as part of the annual service. The inspection plan is then completed with the owner-operator and signed by the fitter and the owner-operator. The owner-operator receives a copy of the completed inspection plan.

9.3. Maintenance instructions

These instructions detail all work which can be carried out by the owner-operator's maintenance staff.



NOTE!

Work which may only be carried out by MIWE service is not described in detail.

9.3.1. Cleaning the siphon



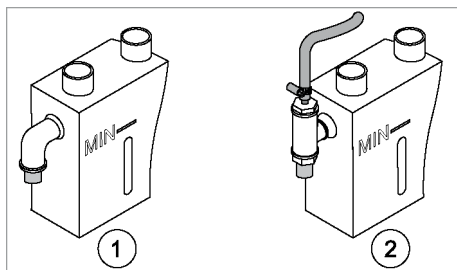
CAUTION: DIRT CAN CAUSE DAMAGE!

A dirty siphon can cause unit malfunction.

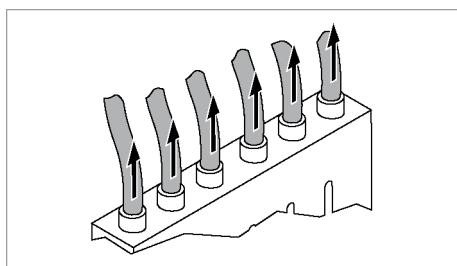
- Clean the siphon in accordance with the maintenance schedule.

Siphon versions

The model depends on the order.



- ① Siphon for oven only
- ② Siphon for oven with proofing cabinet

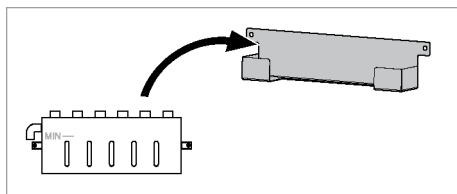
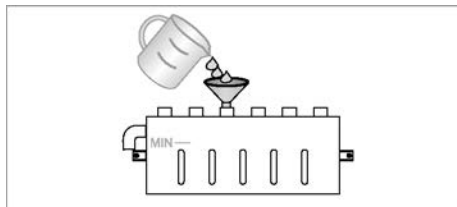
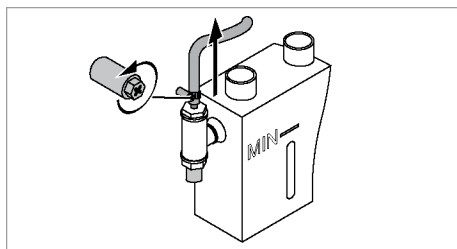
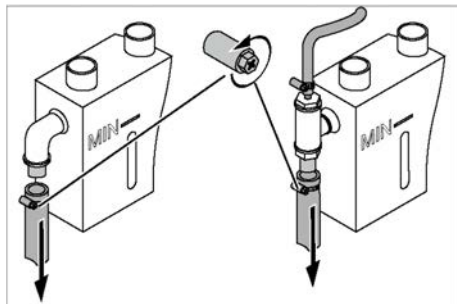
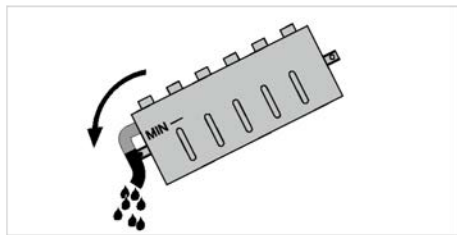


1. Switch off the power supply to the unit and make sure it cannot be switched back on. Allow the unit to cool down to ambient temperature.
2. Pull the water drainage hoses up and out of the siphon.

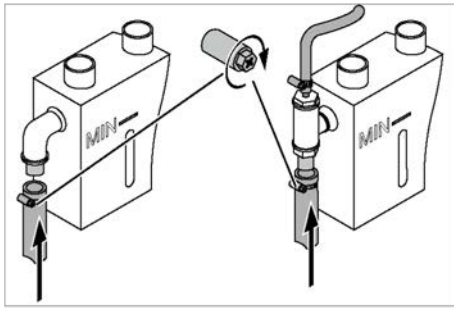


NOTE!

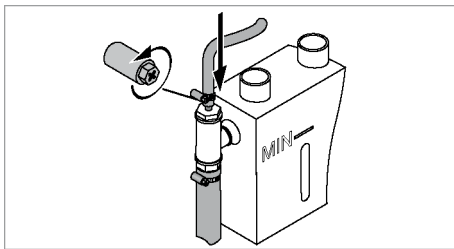
Mark the water drainage hoses to ensure that they are put back in the correct siphon opening afterwards.



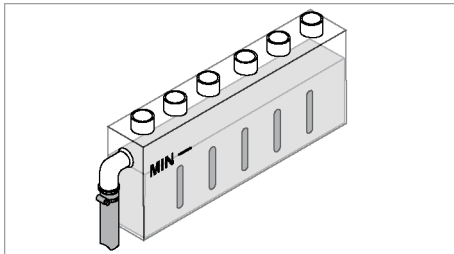
3. Remove the siphon from the siphon bracket and tilt to allow the water to drain out through the hose.
4. Use a suitable tool to loosen the screw in the hose clamp of the water drainage hose, and pull off the hose.
5. Model with siphon at the proofing cabinet:
Also loosen the screw in the hose clamp on the steam cylinder waste water hose using a suitable tool.
6. Rinse out the siphon:
Use warm water and non-abrasive cleaner.
7. Rinsing out the water drainage hose:
For further information, please see 'Rinsing the water drainage hoses'.
8. Place siphon in siphon bracket.



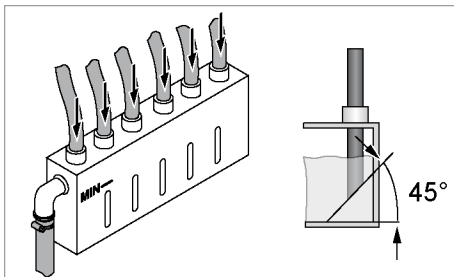
9. Push the water drainage hose with hose clamp onto the water drain. Tighten the hose clamp screw with a suitable tool.



10. Model with siphon at the proofing cabinet:
Also attach steam cylinder waste water hose to the top of the water drain. Tighten the hose clamp screw with a suitable tool.



11. Fill the siphon with water up to the MIN mark.



12. Push the water drainage hoses (angled) down to c. 2 cm from the bottom of the siphon as marked.

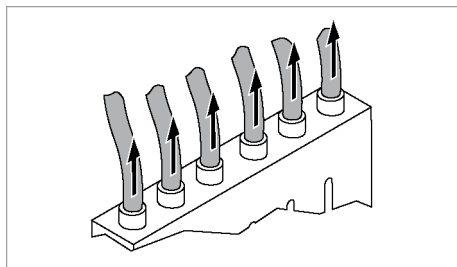
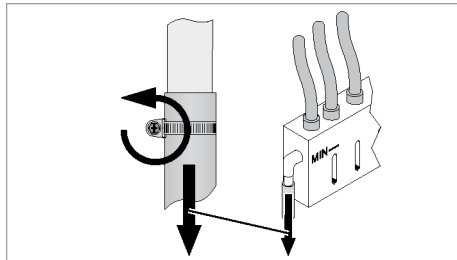


CAUTION: DIRT CAN CAUSE DAMAGE!

If, in the siphon, the water drainage hoses from the

- steam condenser (optional)
 - steam duct / steam discharge
- are in the water, they can get dirty over time and affect the flow.
- Make sure when inserting the drainage hoses into the siphon that they are above the water drain.

9.3.2. Rinsing the water drainage hoses

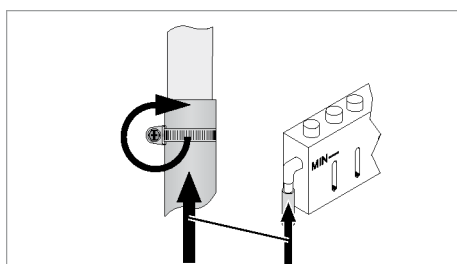
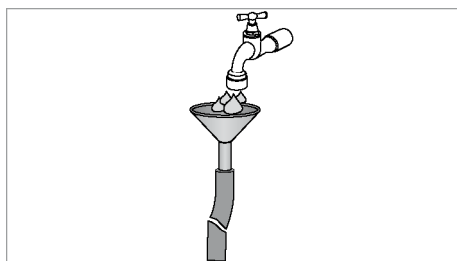
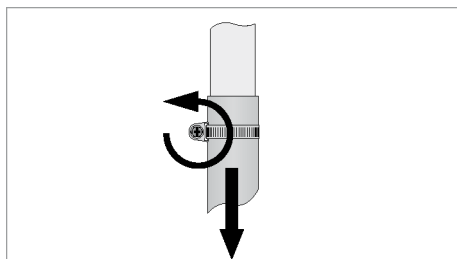


1. Switch off the power supply to the unit and make sure it cannot be switched back on.
Allow the unit to cool down to ambient temperature.
2. Remove the water drainage hose from the siphon:
Use a suitable tool to loosen the screw in the hose clamp, and pull off the water drainage hose.
3. Pull the water drainage hoses up and out of the siphon.

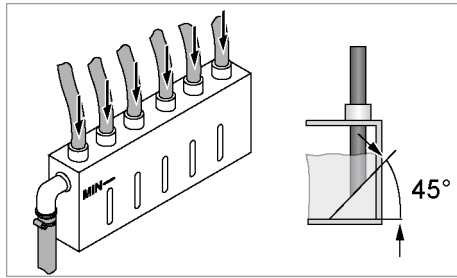


NOTE!

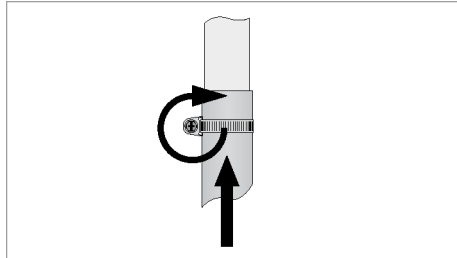
Mark the water drainage hoses to ensure that they are put back in the correct siphon opening afterwards.



4. Remove the water drainage hoses from the units:
Use a suitable tool to loosen the screw in the hose clamp, and pull off the water drainage hose.
5. Rinse out the water drainage hoses:
Pour c. 2 litres of warm water into the top of the water drainage hose.
6. Push the water drainage hose with hose clamp onto the siphon water drain.
Tighten the hose clamp screw with a suitable tool.



7. Push the water drainage hoses (angled) down to c. 2 cm from the bottom of the siphon as marked.



8. Push the water drainage hoses with hose clamps onto the unit condensate outlet. Tighten the hose clamp screw with a suitable tool.

9.3.3. Changing the door seal

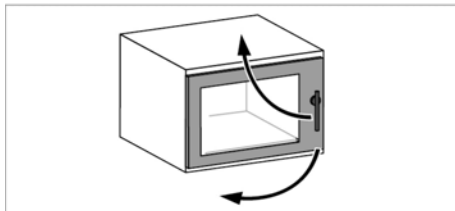
The door seal can become worn over time. Worn seals must be changed immediately.



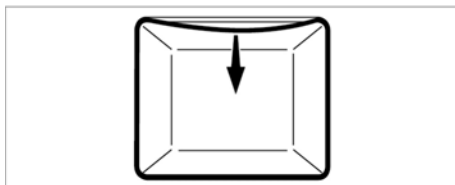
1. Switch off the power supply to the unit and make sure it cannot be switched back on. Allow the unit to cool down to ambient temperature.



2. Wear the prescribed protective clothing for all work.



3. Open the baking chamber door.



4. Pull the defective door seal out of the seal groove.

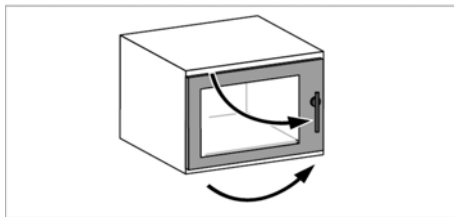
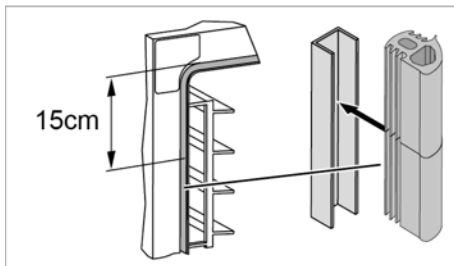


5. Clean the seal groove with a suitable tool.



NOTE!

Ensure that the door seal does not get twisted and that it lies flush. Ensure the door seal has no kinks in the corners.

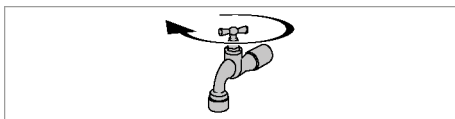


6. Press the new door seal into the seal groove.
 - Do not shorten the door seal.
 - Do not pull the door seal when inserting it.
 - Gently press the door seal into the groove.

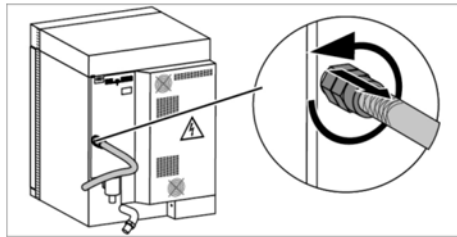
The door seal should be attached on the hinge side c. 15 cm from the top.
7. Close the baking chamber door.

9.3.4. Cleaning the filter in the water system connection piece

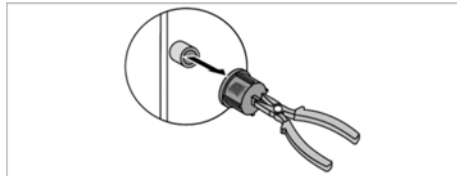
The filter prevents foreign particles from getting into the unit through the water supply line. Clean the filter in accordance with the maintenance schedule.



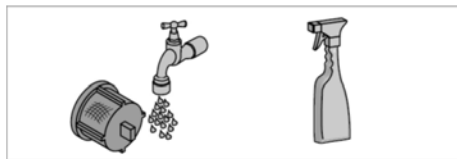
1. Close the shut-off valve in the water supply line.
2. Select a baking program with steam input.
3. Wait until ready to bake.
4. Start the baking program.
The water supply line will be depressurised.
5. Stop the baking program after c. 20 seconds.
6. Switch the controls OFF.
7. Switch off the power supply to the unit and make sure it cannot be switched back on.
Allow the unit to cool down to ambient temperature.
8. Wear the prescribed protective clothing for all work.



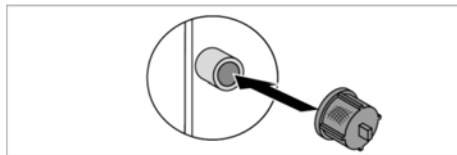
9. Unscrew the union nut from the water supply hose using a suitable tool.



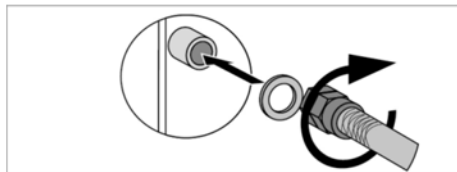
10. Pull out the filter using a suitable tool.



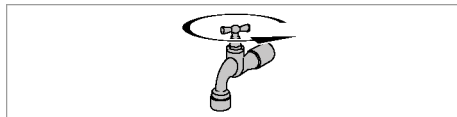
11. Clean the filter with a soft brush under running water.
Use a suitable descaler in case of heavy limescale.
Replace filter if necessary.



12. Insert the filter.



13. Insert new sealing ring in the hose and fasten hose using a suitable tool.



14. Open the shut-off valve in the water supply line.



15. Check water supply line for leaks.

16. Switch ON the power supply and the unit. Heat up the unit.

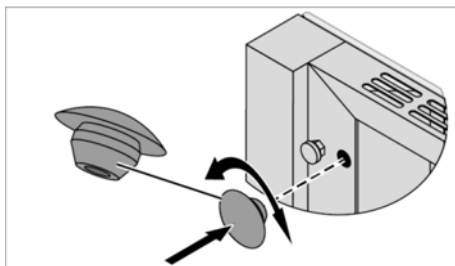
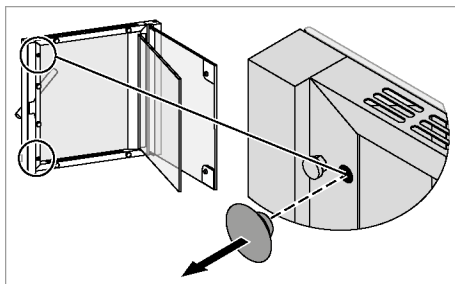
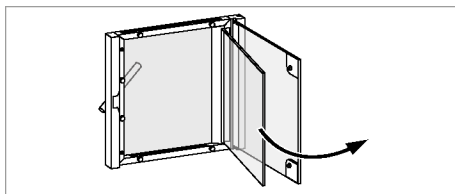
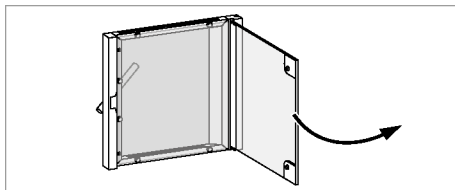
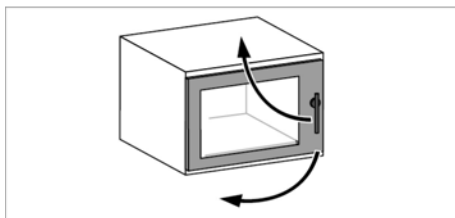


17. Start a baking program with steam input.

18. Stop the baking program after c. 20 seconds.

9.3.5. Replacing the silicone buffers

The door frame is fitted with silicone buffers. These can become worn and each will then need to be replaced.



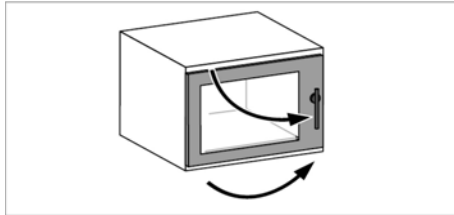
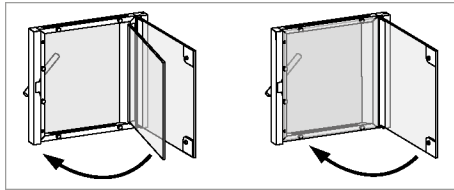
1. Switch off the power supply to the unit and make sure it cannot be switched back on.
Allow the unit to cool down to ambient temperature. When closing the doors, ensure you are well away from the opening.
2. Wear the prescribed protective clothing for all work.
3. Open the baking chamber door.
4. Open the inside glass panel into the baking chamber.
5. Open the (optional) middle glass panel into the baking chamber.
6. Remove silicone buffer from the door frame with a suitable tool.
7. Twist new silicone buffers into the door frame.



WARNING: INSIDE PANEL MAY BREAK!

The inside glass panel can be irreparably damaged when the baking chamber door is closed.

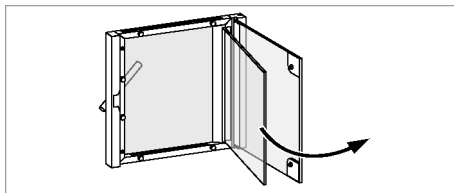
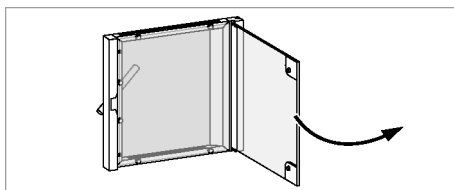
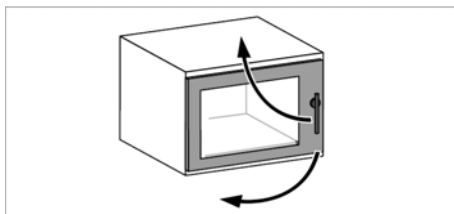
- Close the inside panel before closing the baking chamber door.



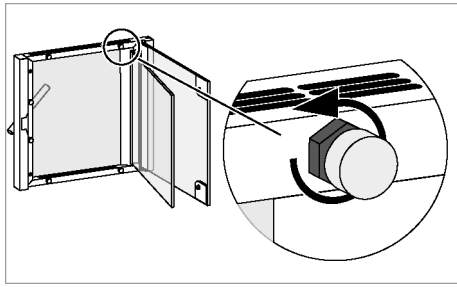
8. Close the (optional) middle panel first and then the inside panel.
The magnets pose a crush hazard when the glass panels are being closed. Close panel carefully.
9. Close the baking chamber door.

9.3.6. Changing the stop buffers

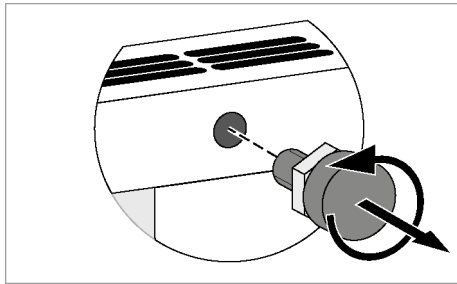
Stop buffers are fitted to the unit baking chamber door. They stop the inside glass panel vibrating. The stop buffers can age over time and each will then need to be replaced.



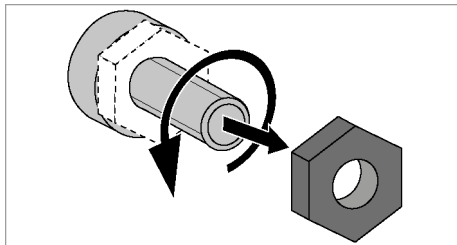
1. Switch off the power supply to the unit and make sure it cannot be switched back on.
Allow the unit to cool down to ambient temperature. When closing the doors, ensure you are well away from the opening.
2. Wear the prescribed protective clothing for all work.
3. Open the baking chamber door.
4. Open the inside glass panel into the baking chamber.
5. Open the (optional) middle glass panel into the baking chamber.



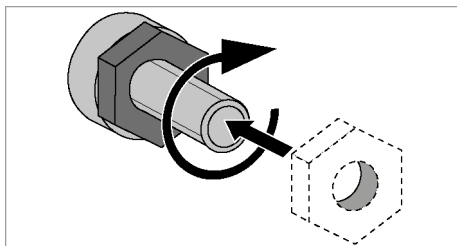
6. Unscrew hexagon nut with a suitable tool.



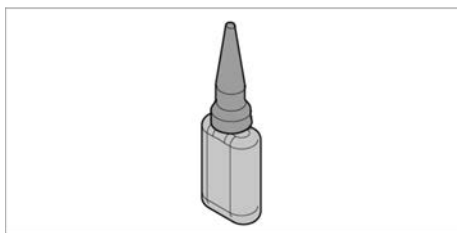
7. Screw the stop buffer with hexagon nut out of the door frame.



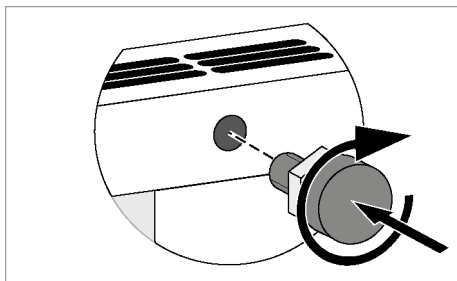
8. Unscrew hexagon nut from stop buffer with a suitable tool.



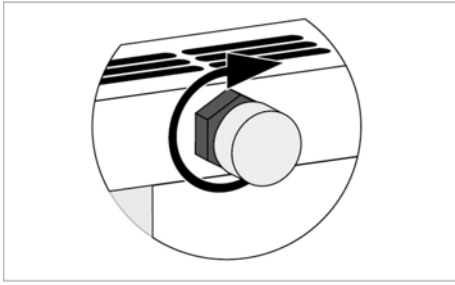
9. Screw hexagon nut onto new stop buffer with a suitable tool and tighten.



10. Coat the thread of the stop buffer with glue to secure.



11. Screw the new stop buffer into the door frame.



12. Tighten hexagon nut with a suitable tool.



WARNING: GLASS PANELS MAY BREAK!

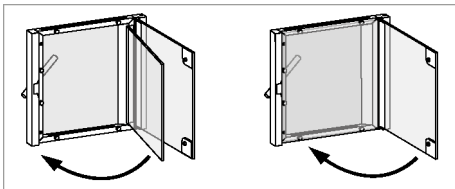
If the stop buffer is not twisted in far enough, this can put tension on the glass panel and cause it to burst.



WARNING: INSIDE PANEL MAY BREAK!

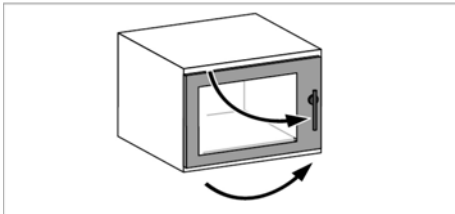
The inside glass panel can be irreparably damaged when the baking chamber door is closed.

- Close the inside panel before closing the baking chamber door.



13. Close the (optional) middle panel first and then the inside panel.

The magnets pose a crush hazard when the glass panels are being closed. Close panel carefully.



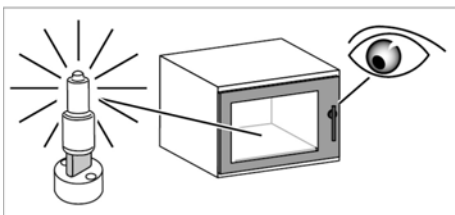
14. Close the baking chamber door.



CAUTION!

If the stop buffer is not screwed out far enough, steam and liquid may escape.

- There must not be a gap between the inside glass panel and the door seal.



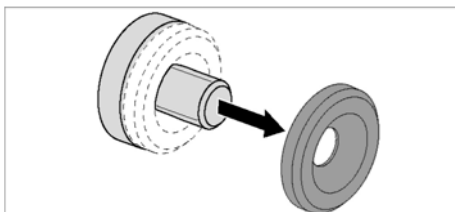
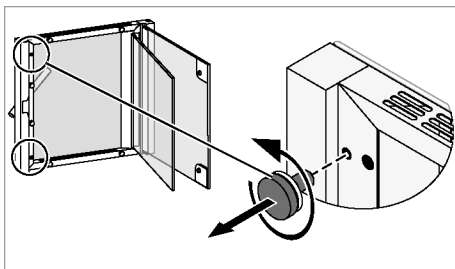
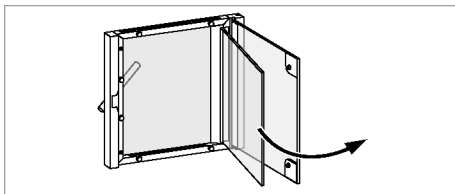
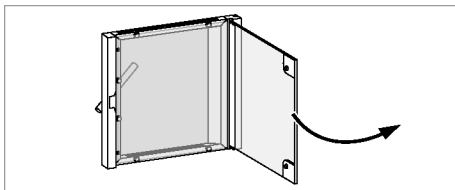
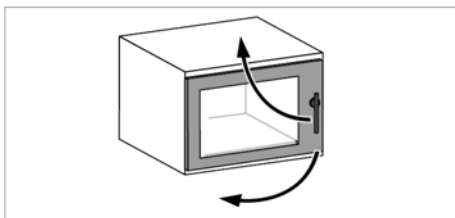
15. Visual inspection for leaks:

Switch on the baking chamber lighting and look for gaps.

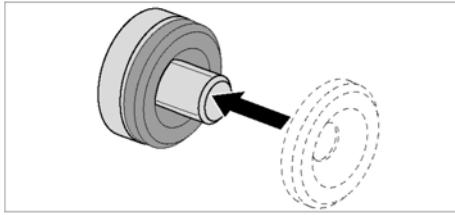
Twist in or twist out stop buffer as required.

9.3.7. Changing magnets on the door frame

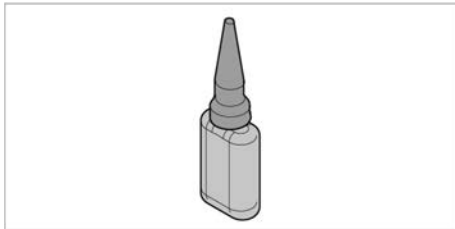
There are magnets on the door frame that age over time. The magnets can be changed individually.



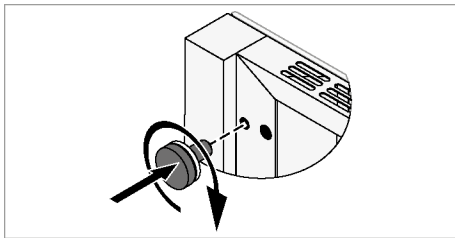
1. Switch off the power supply to the unit and make sure it cannot be switched back on.
Allow the unit to cool down to ambient temperature. When closing the doors, ensure you are well away from the opening.
2. Wear the prescribed protective clothing for all work.
3. Open the baking chamber door.
4. Open the inside glass panel into the baking chamber.
5. Open the (optional) middle glass panel into the baking chamber.
6. Screw the magnet and spacer out of the door frame.
7. Remove the spacer from the magnet.



8. Place spacer on new magnet.



9. Coat the thread of the magnet with glue to secure. For further information, please see 'Wear and spare parts list'.



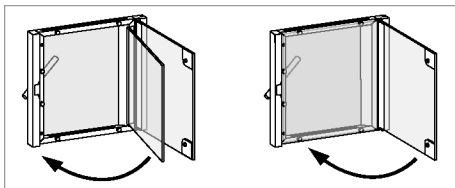
10. Screw the new magnet into the door frame.



CAUTION!

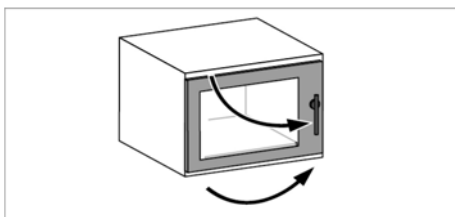
The inside glass panel can be irreparably damaged when the baking chamber door is closed.

- Close the inside panel before closing the baking chamber door.



11. Close the (optional) middle panel first and then the inside panel.

The magnets pose a crush hazard when the glass panels are being closed. Close panel carefully.



12. Close the baking chamber door.

9.3.8. Replacing lamps

Model with LED lighting (optional)



NOTE!

The LED lighting requires no maintenance.
Contact MIWE service in the event of damage or defects.

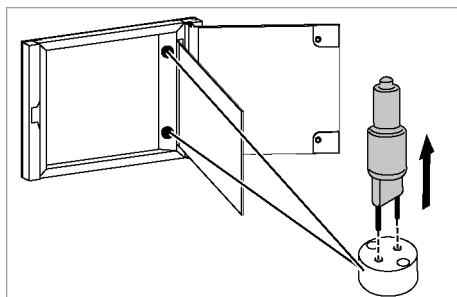
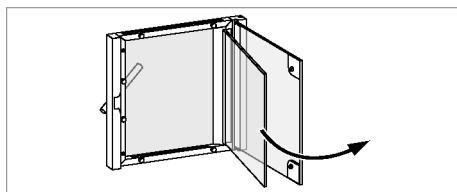
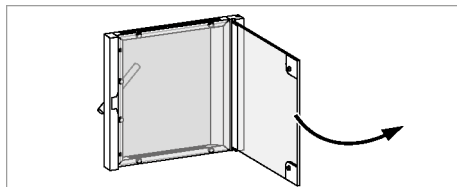
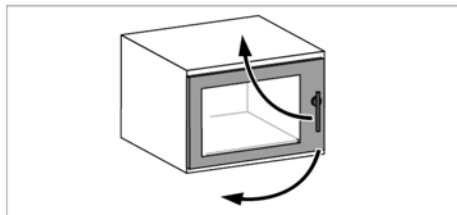
Model with halogen lamp (optional)



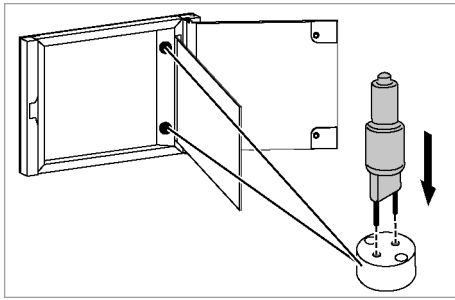
CAUTION: DO NOT TOUCH!

Touching the lamps with your bare hands can damage them.

- Always use a cloth or clean gloves when touching lamps.



1. Switch off the power supply to the unit and make sure it cannot be switched back on.
Allow the unit to cool down to ambient temperature.
When closing the doors, ensure you are well away from the opening.
2. Wear the prescribed protective clothing for all work.
3. Open the baking chamber door.
4. Open the inside glass panel into the baking chamber.
5. Open the (optional) middle glass panel into the baking chamber.
6. Pull the lamp out of the socket and dispose of it.



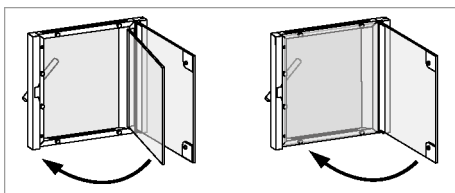
7. Insert a new lamp into the socket and slot into place.



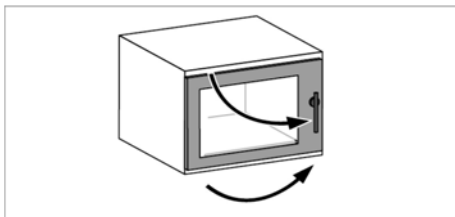
CAUTION!

The inside glass panel can be irreparably damaged when the baking chamber door is closed.

- Close the inside panel before closing the baking chamber door.



8. Close the (optional) middle panel first and then the inside panel.
The magnets pose a crush hazard when the glass panels are being closed. Close panel carefully.



9. Close the baking chamber door.

9.4. Start-up after maintenance



1. Check all electrical connections are correctly fitted and secure.
2. Remove all tools and auxiliary materials from the unit.
3. Remove any foreign objects from the unit.
4. Close all maintenance hatches/openings.
5. Check all screwed connections are securely fitted and tight.
6. Switch ON the power supply.
7. Clear or acknowledge all faults.
8. Open the water feed line
9. Check function by performing a test run.

10. Technical data



NOTE!

The detailed technical data is sent to the owner-operator together with the order confirmation.

10.1. Technical data – product versions

	AE 4.0604 e+	AE 6.0604 e+	AE 8.0604 e+	AE 10.0604 e+
Number of trays	4	6	8	10
Baking tray size in cm	60/40	60/40	60/40	60/40
Baking area in m ²	0.96	1.44	1.92	2.4
Airborne sound emissions in dB (A)	< 70	< 70	< 70	< 70



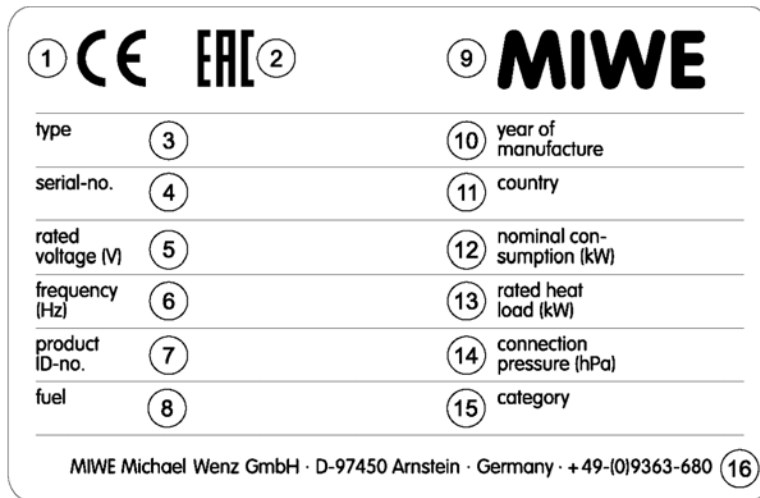
NOTE!

Surface temperature at the oven:

- Metal surfaces 65°C
- Glass surfaces 80°C

Depending on the place of installation and baking temperature, the temperature may be higher at certain points.

10.2. Rating plate



- ① EU approval
- ② Approval for European Economic Area
- ③ Machine type
- ④ Serial number
- ⑤ Rated voltage
- ⑥ Frequency
- ⑦ Product ID no.
- ⑧ Fuel
- ⑨ Manufacturer logo
- ⑩ Year of manufacture
- ⑪ Country
- ⑫ Rated input
- ⑬ Rated heat load
- ⑭ Input pressure
- ⑮ Category
- ⑯ Manufacturer address

11. Wear and spare parts list

For information on how to replace wear and spare parts, see "Inspection and maintenance".



WARNING: USING THE WRONG SPARE PARTS CAN CAUSE MALFUNCTIONS!

Use of incorrect or defective spare parts can result in damage, malfunctions and even total failure and may also compromise safety, and will render the warranty void.

- Only ever use MIWE spare parts.

Wear part

- Will inevitably become worn during use.
- Must be regularly replaced by the customer or MIWE service in accordance with the maintenance schedule.
- Must be paid for by the customer regardless of any warranty.
- Can be offered by MIWE as a package.

Spare part

- From individual parts to entire modules.
- Free of charge for the customer under the statutory or agreed warranty.
- Must be paid for by the customer if the customer is shown to not have met its maintenance obligations.
- Must be paid for by the customer upon expiry of the warranty.
- Replaced by the customer or only by MIWE service or authorised qualified personnel, depending on the requirements.

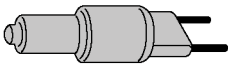

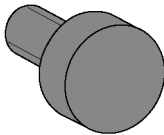
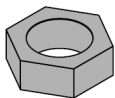
Image	Item number	Designation
	504588.13	Halogen lamp G4 12V 20W
	189016.01	Door seal for 4.0604
	189016.02	Door seal for 6.0604
	189016.03	Door seal for 8.0604
	189016.04	Door seal for 10.0604
	507182.07	"D" stop buffer, 15x8 M4x10
	501201.10	DIN934-A2 M4 nut

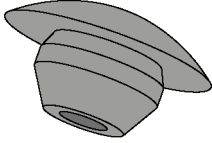
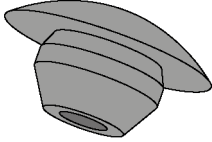

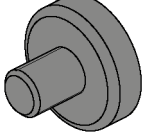
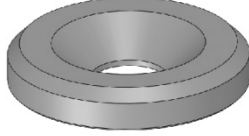


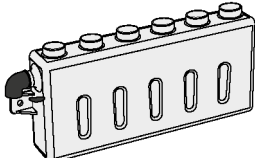
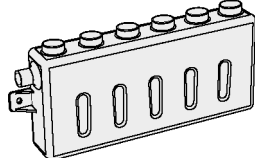
Image	Item number	Designation
	507183.60	Silicone buffer, 13/7 x 7 H=3
	507182.25	Rubber buffer, Ø 9.3
	507187.01	Black cover cap, 10.3 mm
	506949.52	Magnet, Ø20 externally threaded pin M6
	085615.00	Concave spacer, Ø20
	507431.00	Steam hose (3/4"), 19x6.5 NBR
	507439.30	Water supply hose, FL 3/4"x3000
	187416.60	Discharge siphon, cpl. 3/4"
	071190.04	Discharge siphon


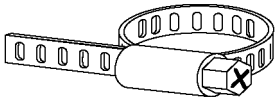
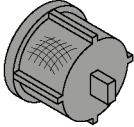

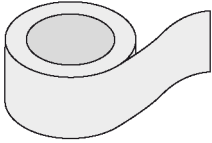

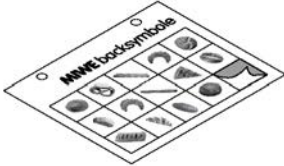
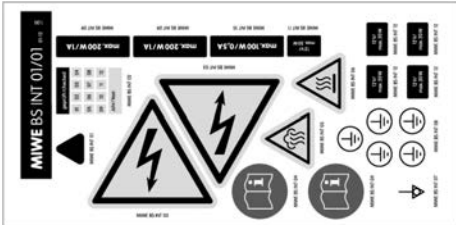

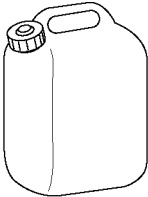


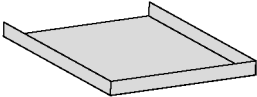



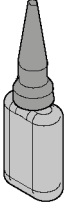
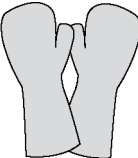
Image	Item number	Designation
	508507.01	Bracket *3090* red brass 90° fem. 3/4x1/2"
	507436.00	Clamp thread 25-40
	505210.01	Plastic filter, type "C"
	506582.10	Silicone pipe, D=80
	506597.10	Repair tape, self-amalgamating, width=50mm
	187777.20	Nozzle, cpl. l=40
	507340.04	MIWE baking symbol pictogram
	507330.00	Baking station signs and labels, internation.
	188338.10	Box of 6 bottles of MIWE cleaner CC 3.0

Image	Item number	Designation
	506340.05	Tank/canister, capacity 20 l Also order the two adhesive notices 'Drinking water' and 'Not drinking water' with this item.
	187961.60	"Drinking water" notice
	187961.70	"Not drinking water" notice
	On request	Baking tray
	506800.57	BRITA PURITY 450 STEAM WITH MDU
	506800.58	BRITA PURITY 600 STEAM WITH MDU
	506800.59	BRITA PURITY 1200 STEAM WITH MDU
	506800.64	Replacement cartridges BRITA PURITY 450 STEAM
	506800.65	BRITA PURITY 600 STEAM
	506800.66	BRITA PURITY 1200 STEAM
	506775.01	Stainless steel care spray, 500 ml
	507536.16	LOCTITE type 243, 5 ml
	506773.01	Heat-resistant gloves, 'BRICKMAN' MIWE

12. Shut-down and disposal

12.1. Safety information



RISK OF ELECTROCUTION!

Live lines can cause serious injury and even death.

- Before any work, switch off the power supply to the unit and make sure it cannot be switched back on, and check that no parts are live.



DANGER OF INJURY FROM FALLING PARTS!

Falling parts can cause serious injury and even death.

- Use the tools and equipment specified.



DANGER TO LIFE FROM GAS, WATER AND COMPRESSED AIR!

Escaping gas, water and compressed air can cause serious injury and even death.

- Disconnect and secure all supply lines to the unit before dismantling.

12.2. Environmental protection

- Remove all service fluids and parts that are in contact with these substances from the unit.
- Disassembled parts and waste must be disposed of by an authorised company in compliance with the provisions for recycling and special waste applicable at the place of installation.

13. EC declaration of conformity

Declaration of EC conformity

in accordance with EC Directive 2006/42/EC Annex II A
relating to machinery

MIWE

We,

MIWE Michael Wenz GmbH
Michael-Wenz-Str. 2-10
D - 97450 Arnstein

declare that the design and construction of the product below for processing baked goods and the condition and form in which it has been put on the market by us complies with the applicable provisions of the above EC Directives.

Changes to the product or to parts thereof shall render this declaration null and void.

Machine type: Convection baking oven (Konvektionsbackofen)
Designation of type: MIWE aero e+ 3.0
Serial number: from 822967
Year of construction: from 2016

Regulations applied:

- EC Directive 2006/42/EC, Annex I
- EC Directive 2004/108/EC
- EC Directive 2006/95/EC

Harmonized standards applied:

- EN ISO 12100:2010
- EN 60335-1:2012
- EN 60335-2-42:2012
- EN 13732-1:2008
- EN 61000-6-2:2006, EN 61000-6-3:2011
- EN 1672-2:2005+A1:2009

Person authorized to draw up the documentation:

Dipl.-Ing. (FH) Bernhard Kusche
MIWE Michael Wenz GmbH
Michael-Wenz-Str. 2-10
D - 97450 Arnstein
Telephon: +49 (0) 9363 68 8618

Arnstein, 2016-03-31



CE-coordinator

Dipl.-Ing.(FH) Bernhard Kusche

Author:
Bernhard Kusche

Document:
Serienkonfo_MIWE_aero_3.0_ab_822967_ab_2016_EN.docx

Page 1 of 1

14. Baking programs

The settings in the following program examples are guide values only. Minor adjustments for optimisation are left to the user.



NOTE!

Overloading and unevenly loading trays can affect results.

- Please note the information in the program examples.

Partial loads



NOTE!

When baking, make sure that the products or tray loads to be baked are placed in the centre of the available baking space. This stops the products browning too much at the edges.

When using greaseproof paper/baking parchment, make sure that it does not cover the products during baking.

- Arrange products carefully at the edge.

14.1. Baking tips

The baking tips are detailed in each baking phase.



1st baking phase

1. Set an initial temperature of 200°C–220°C (standard).
2. If required, set the water quantity for steam:

Low:	20 – 40 ml	•	Per tray with full oven load
Normal:	40 – 60 ml	•	The values depend on the product and oven size.
High:	60 – 100 ml		

2nd baking phase

3. The baking temperature is generally c. 180°C.
This phase is the actual baking phase.

3rd baking phase

4. Depending on how brown you want your products, you can increase or decrease the temperature.

Baking processes – MIWE Convenience settings

Setting 0	Classic Prepare dough – Proof – Bake – Transport – Sell
Setting 1	Long-cycle, MIWE smartproof Prepare dough – Proof – Cool – Transport – Bake – Sell
Setting 2	Frozen unproofed Prepare dough – Freeze – Store frozen – Transport – Store frozen – Defrost – Proof – Bake – Sell
Setting 3	Proofed and frozen, baking from frozen Prepare dough – Proof – Freeze – Store frozen – Transport – Store frozen – Bake from frozen – Sell
Setting 4	Semi-baked and frozen Prepare dough – Proof – Bake – Freeze – Store frozen – Transport – Store frozen – Bake – Sell
Setting 5	Baked and frozen Prepare dough – Proof – Bake – Freeze – Store frozen – Transport – Store frozen – Defrost/Regenerate – Sell

14.2. Sample programs

Program: Kaiser rolls, 60 g



Number of pieces of dough: 3 x 5

Baking process: MIWE Convenience setting 0

Additional information: Bake immediately after proofing (fully proofed)

Baking phases	1	2	3	4	5	Σ
	1:30	13:30	3:00			18:00
	210	180	185			
	0	4	4			
	Normal	Normal	Normal			
	4	400	-	-		
	6	600				
	8	800				
	10	1000				
	CLOSED	CLOSED	OPEN			







Program: **Plain rolls, 55 g**



Number of pieces of dough: 3 x 5

Baking process: MIWE Convenience setting 0

Additional information: Proofing on proofing boards (short proofing).

Baking phases	1	2	3	4	5	Σ
	2:00	13:00	3:00			18:00
	220	180	185			
	0	4	4			
	Normal	Normal	Normal			
	4	400	-	-		
	6	600				
	8	800				
	10	1000				
	CLOSED	CLOSED	OPEN			

Program: **Deep-frozen plain rolls,
55 g**



Number of pieces of dough: 3 x 5

Baking process: MIWE Convenience setting 3

Additional information: Load frozen.

Baking phases	1	2	3	4	5	Σ
	6:00	1:30	13:00	5:00		25:30
	190	170	180	185		
	4	2	4	4		
	Frozen dough	Normal	Normal	Normal		
	4	400	4	100	-	-
	6	600	6	140		
	8	800	8	200		
	10	1000	10	240		
	CLOSED	CLOSED	CLOSED	OPEN		

Program: **Par-baked
plain rolls, 60 g**



Number of pieces of dough: 3 x 5

Baking process: MIWE Convenience setting 4

Additional information: Load after defrosting for 15 minutes.

Baking phases	1	2	3	4	5	Σ
	0:20	9:40	2:00			12:00
	220	190	190			
	0	4	4			
	Normal	Normal	Normal			
	4	120	-	-		
	6	180				
	8	240				
	10	300				
	CLOSED	CLOSED	OPEN			

Program: **Seeded rolls, 60 g**



Number of pieces of dough: 3 x 5

Baking process: MIWE Convenience setting 0

Additional information: Proofing on proofing boards (short proofing).

Baking phases	1	2	3	4	5	Σ
	1:30	14:30	3:00			19:00
	210	180	180			
	0	4	4			
	Normal	Normal	Normal			
	4	400	-	-		
	6	600				
	8	800				
	10	1000				
	CLOSED	CLOSED	OPEN			

Program: **Par-baked
seeded rolls, 60 g**



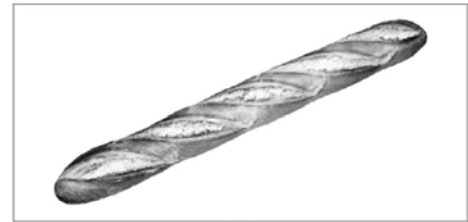
Number of pieces of dough: 3 x 5

Baking process: MIWE Convenience setting 4

Additional information: Load after defrosting for 15 minutes.

Baking phases	1	2	3	4	5	Σ
	0:15	9:45	2:00			12:00
	210	185	185			
	0	4	4			
	Normal	Normal	Normal			
	4	100	-	-		
	6	140				
	8	200				
	10	260				
	CLOSED	CLOSED	OPEN			

Program: **Baguettes, 250 g**



Number of pieces of dough: 4 (crossways)

Baking process: MIWE Convenience setting 0

Additional information: Bake immediately after proofing.

Baking phases	1	2	3	4	5	Σ
	1:30	17:30	5:00			24:00
	210	180	180			
	0	4	4			
	Normal	Normal	Normal			
	4	400	-	-		
	6	600				
	8	800				
	10	1000				
	CLOSED	CLOSED	OPEN			

Program: **Par-baked baguettes, 250 g**



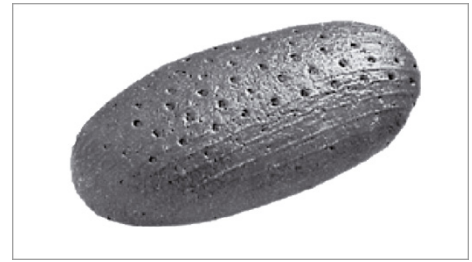
Number of pieces of dough: 4 (crossways)

Baking process: MIWE Convenience setting 4

Additional information: Load after defrosting for 30 minutes.

Baking phases	1	2	3	4	5	Σ
	0:20	12:40	3:00			16:00
	220	190	190			
	0	4	4			
	Normal	Normal	Normal			
	4	120	-	-		
	6	180				
	8	240				
	10	300				
	CLOSED	CLOSED	OPEN			

Program: **Par-baked wheat and rye loaves, 500 g**



Number of pieces of dough: 4

Baking process: MIWE Convenience setting 4

Additional information: Load after defrosting for 60 minutes.

Baking phases	1	2	3	4	5	Σ
	0:30	22:00	3:30			26:00
	220	170	175			
	0	4	4			
	Normal	Normal	Normal			
	4	100	-	-		
	6	140				
	8	200				
	10	260				
	CLOSED	CLOSED	OPEN			

Program: **Pretzels, 75 g**



Number of pieces of dough: 3 x 4

Baking process: MIWE Convenience setting 0

Additional information: Sprinkle with salt and load immediately.

Baking phases	1	2	3	4	5	Σ
	1:00	13:00				14:00
	210	175				
	4	4				
	Normal	Normal				
	-	-				
	OPEN	OPEN				

Program: **Deep-frozen pretzels, 75 g**



Number of pieces of dough: 3 x 4

Baking process: MIWE Convenience setting 3

Additional information: Defrost for 10 minutes, sprinkle with salt and load immediately.

Baking phases	1	2	3	4	5	Σ
	1:00	14:00				15:00
	210	180				
	4	4				
	Normal	Normal				
	-	-				
	OPEN	OPEN				

Program: **Croissants, 60 g**



Number of pieces of dough: 3 x 4

Baking process: MIWE Convenience setting 0

Additional information: Bake immediately after proofing.

Baking phases	1	2	3	4	5	Σ
	1:30	2:00	10:30	4:00		18:00
	190	170	180	185		
	0	2	4	4		
	Normal	Normal	Normal	Normal		
	4	300	-	-	-	
	6	460				
	8	600				
	10	760				
	CLOSED	CLOSED	CLOSED	OPEN		

Program: **Deep-frozen croissants,
75 g**



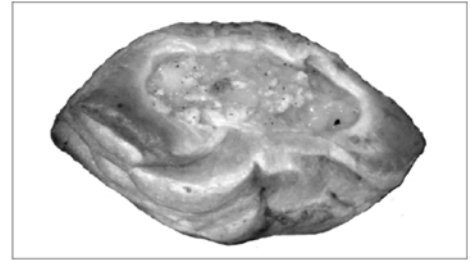
Number of pieces of dough: 3 x 4

Baking process: MIWE Convenience setting 3

Additional information: Load frozen.

Baking phases	1	2	3	4	5	Σ
	3:00	3:00	11:00	3:00		20:00
	190	170	180	185		
	4	2	4	4		
	Frozen dough	Normal	Normal	Normal		
	4	300	-	-	-	
	6	460				
	8	600				
	10	760				
	CLOSED	CLOSED	CLOSED	OPEN		

Program: **Danish pastries, 120 g**



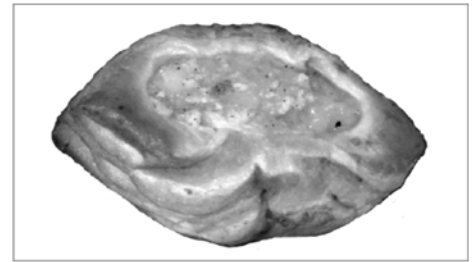
Number of pieces of dough: 3 x 4 (diagonally)

Baking process: MIWE Convenience setting 0

Additional information: Bake immediately after proofing.

Baking phases	1	2	3	4	5	Σ
	1:30	4:00	11:00	4:00		20:30
	180	180	180	185		
	0	2	4	4		
	Normal	Normal	Normal	Normal		
	4	300	-	-	-	
	6	460				
	8	600				
	10	760				
	CLOSED	CLOSED	CLOSED	OPEN		

Program: **Deep-frozen Danish pastries, 120 g**



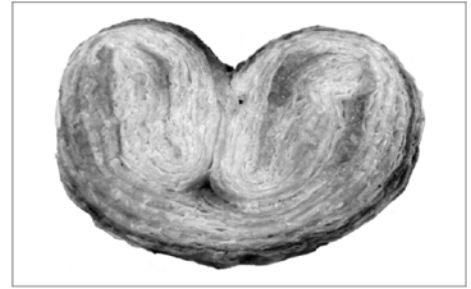
Number of pieces of dough: 3 x 4 (diagonally)

Baking process: MIWE Convenience setting 3

Additional information: Load after defrosting for 15 minutes.

Baking phases	1	2	3	4	5	Σ
	3:00	3:00	13:00	4:00		23:00
	190	170	180	185		
	4	2	4	4		
	Frozen dough	Normal	Normal	Normal		
	4	300	-	-	-	
	6	460				
	8	600				
	10	760				
	CLOSED	CLOSED	CLOSED	OPEN		

Program: **Puff pastry, 100 g**



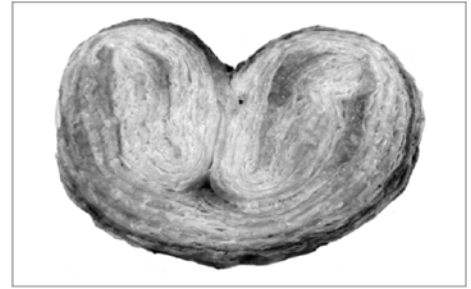
Number of pieces of dough: 3 x 3 (crossways)

Baking process: MIWE Convenience setting 0

Additional information: Bake immediately after proofing.

Baking phases	1	2	3	4	5	Σ
	0:30	16:30	3:00			20:00
	210	180	180			
	0	4	4			
	Normal	Normal	Normal			
	4	200	-	-		
	6	300				
	8	400				
	10	500				
	CLOSED	CLOSED	OPEN			

Program: **Deep-frozen puff pastry,
100 g**



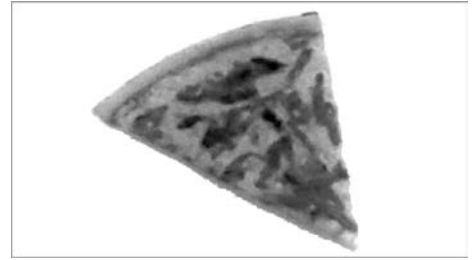
Number of pieces of dough: 3 x 3 (crossways)

Baking process: MIWE Convenience setting 3

Additional information: Load after defrosting for 15 minutes.

Baking phases	1	2	3	4	5	Σ
	1:00	3:00	11:00	5:00		20:00
	220	170	180	180		
	0	2	4	4		
	Normal	Normal	Normal	Normal		
	4	200	-	-	-	
	6	300				
	8	400				
	10	500				
	CLOSED	CLOSED	CLOSED	OPEN		

Program: **Pizza, 130 g**



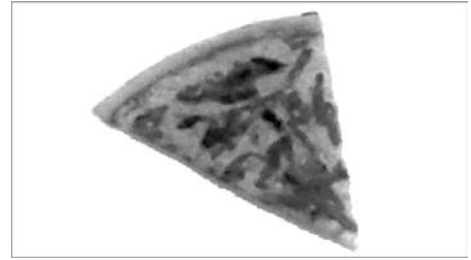
Number of pieces of dough: -

Baking process: MIWE Convenience setting 0

Additional information: Add topping and bake immediately

Baking phases	1	2	3	4	5	Σ
	1:00	3:00	2:00			6:00
	210	190	190			
	4	4	4			
	Normal	Normal	Normal			
	-	-	-			
	CLOSED	CLOSED	OPEN			

Program: **Deep-frozen pizza, 130 g**



Number of pieces of dough: -

Baking process: MIWE Convenience setting 4

Additional information: Load frozen.

Baking phases	1	2	3	4	5	Σ
	1:00	4:00	3:00			8:00
	210	190	190			
	4	4	4			
	Normal	Normal	Normal			
	-	-	-			
	CLOSED	CLOSED	OPEN			







Program: **Cookies, 85 g**



Number of pieces of dough: 3 x 4

Baking process: MIWE Convenience setting 0

Additional information: Bake immediately after preparation.

Baking phases	1	2	3	4	5	Σ
	1:00	15:00				16:00
	180	160				
	4	4				
	Normal	Normal	-			
	-	-	-			
	CLOSED	CLOSED				


Program: **Muffins, 130 g**



Number of pieces of dough: 4 x 6

Baking process: MIWE Convenience setting 0

Additional information: Bake immediately after preparation.

Baking phases	1	2	3	4	5	Σ
	6:00	14:00	6:00			26:00
	180	165	165			
	2	4	4			
	Normal	Normal	Normal			
	-	-	-			
	CLOSED	CLOSED	OPEN			







Templates for entering individual baking programs

Program: _____

Number of pieces of dough: _____

Baking process: _____

Additional information: _____







Baking phases	1	2	3	4	5	Σ
						
						
						
						
						
						

Program: _____

Number of pieces of dough: _____

Baking process: _____

Additional information: _____







Baking phases	1	2	3	4	5	Σ
						
						
						
						
						
						

Program: _____

Number of pieces of dough: _____

Baking process: _____

Additional information: _____







Baking phases	1	2	3	4	5	Σ
						
						
						
						
						
						

Program: _____

Number of pieces of dough: _____

Baking process: _____

Additional information: _____







Baking phases	1	2	3	4	5	Σ
						
						
						
						
						
						

Program: _____

Number of pieces of dough: _____

Baking process: _____

Additional information: _____







Baking phases	1	2	3	4	5	Σ
						
						
						
						
						
						

Program: _____

Number of pieces of dough: _____

Baking process: _____

Additional information: _____

Baking phases	1	2	3	4	5	Σ
						
						
						
						
						
						

Program: _____

Number of pieces of dough: _____

Baking process: _____

Additional information: _____

Baking phases	1	2	3	4	5	Σ
