

**POWERS**

EQUIPMENT COMPANY

105 Steamboat Drive • Warminster, PA 18974 • (215) 675-9220 • (800) 673-7868

Email: sales@powersequiment.com • Website: powersequiment.com

REFRIGERATED EQUIPMENT

MANUFACTURERS

Project Name: \_\_\_\_\_

AIA #

Location: \_\_\_\_\_

Item # \_\_\_\_\_ Qty: \_\_\_\_\_

SIS #

Model #: \_\_\_\_\_

Model:

**FS28SDHC****SWING DOOR FLORAL COOLER**

Swing Door Refrigerator with Hydrocarbon Refrigerant

**STANDARD FEATURES**

- Self contained - ready to plug in.
- R290 hydrocarbon refrigerant is used to comply with all environmental standards. R290 has zero ozone depletion potential (ODP) and three global warming potential (GWP).
- Powder-coat exterior finish.
- Digital temperature control.
- Black PVC double pane glass self closing doors with Low E and argon.
- Hot gas condensate evaporator.
- Switch controlled vertical LED lamps.
- EC fan motors operate at higher peak efficiencies and move a more constant volume of air which produces less heat and reduces energy consumption.
- Adjustable coated wire shelving.
- Balanced refrigeration systems with a temperature range of 35° F to 41° F
- Louvered motor covers.
- Stainless steel bottom floor.
- The entire cabinet is foamed in place using a high density, CFC free polyurethane insulation.



| Model    | Doors | Cabinet Dimensions |     |         | Door Size |     | Shelves | HP  | Plug Type | Voltage  | Amps | Lights | Crated Weight |
|----------|-------|--------------------|-----|---------|-----------|-----|---------|-----|-----------|----------|------|--------|---------------|
|          |       | W                  | D   | H       | W         | H   |         |     |           |          |      |        |               |
| FS28SDHC | 1     | 28 1/4"            | 32" | 74 1/2" | 27"       | 60" | 2       | 1/3 | 5-15P     | 115/60/1 | 4.2  | 1      | 348 lbs       |

**FS28DHC**

## Swing Door Floral Cooler

Swing Door Refrigerator with Hydrocarbon Refrigerant



### OPTIONAL ACCESSORIES

Shelves and clips  
Casters  
Stainless exterior/interior

### STANDARD COLORS

White/Black/Gray/Vanilla

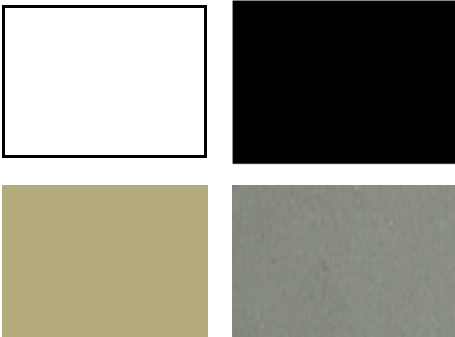

### Model Views

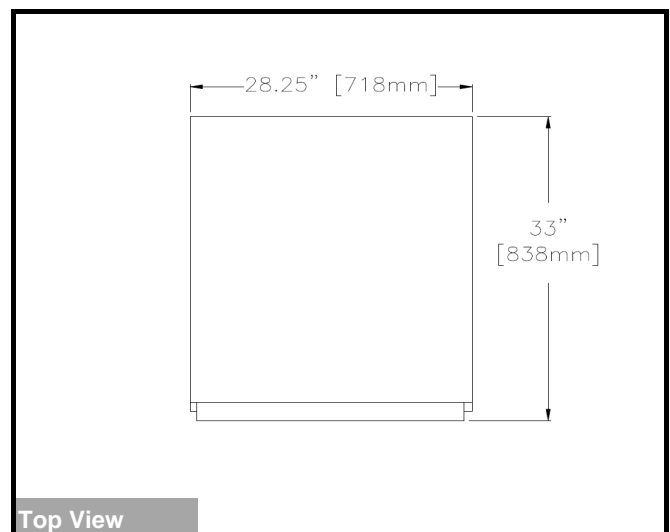
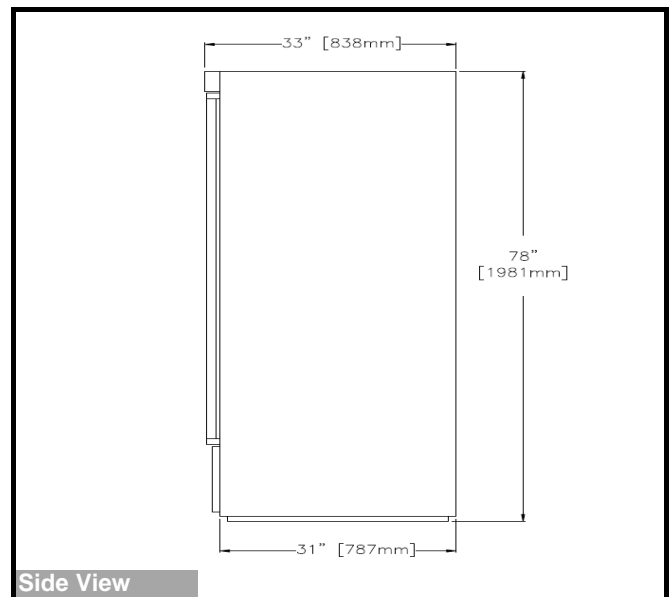
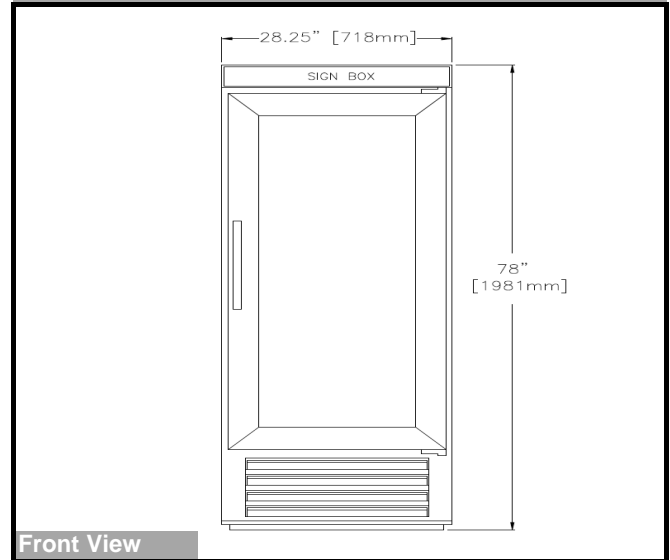

### WARRANTY

#### One Year Parts and Labor

- The warranty is in effect for one year from date of installation.
- Factory service authorization must be obtained before any work may be performed under the labor warranty.
- The warranty covers reasonable labor costs, based on straight time, when the unit has been diagnosed as defective.
- This warranty does not cover original installation, initial start-up, normal adjustments, or maintenance.
- OEM parts needed for warranty must be obtained from Powers Equipment.

#### Five Year Compressor Warranty

Powers warrants to the original purchaser for a period of five years from the date of installation, that we will replace the compressor on the unit if found, in the reasonable opinion of the factory, to be defective in material or workmanship. Relays, overloads, capacitors, and any other electrical components are not included in the five-year warranty.

### ELECTRICAL REQUIREMENTS

- Cooler is pre-wired at factory and ready for connection to a 115/60/1 phase, 15 amp dedicated outlet.



115/60/1  
NEMA-5-15R