



Drago America
www.dragoamerica.com

Project Name: _____

Location: _____

Item #: _____ Qty: _____

Model #: _____

SIA #

AIA #

Model:
DRBB27-23SH

Coolers – Solid Door Hinged Back Bar Cooler 27” Depth
1 solid door 7.8 ft³



Features & Benefits

Strong & Durable Structure

- Stainless steel top, interior walls, floor and ceiling.
- Corrosion resistant vinyl on steel in black finish exterior.

Temperature

- Temperature range 33°F~40°F (0°C~4°C).

User Friendly Features

- Self-closing doors with locks.
- Option of stainless steel exterior available.
- LED interior lighting.
- Adjustable heavy duty PVC coated shelves.
- Easy access to condenser coil for cleaning and service.
- Easy adjust temperature set point and defrost frequency.

Pre-installed heavy-duty casters with brakes.
Refrigerant R290.



Certifications



Intertek



Intertek

Doors	Shelves	HP	AMPS	Crated Weight	Dimensions (inches)		
					W	D	H
1	2	1/4	1.92	177 Lb (80 Kg)	23.5" (596 mm)	30.2" (767 mm)	39.8" (1011 mm)

Packaging dimensions (mm): W 26" (660) x D 32.2" (820) x H 45" (1140)

Approvals:

Available At:

Model:
DRBB27-23SH

Coolers – Solid Door Hinged Back Bar Cooler 27” Depth

1 solid door 7.8 ft³



Plan View

Front View

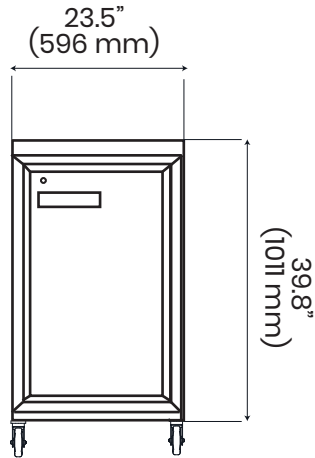

Side View

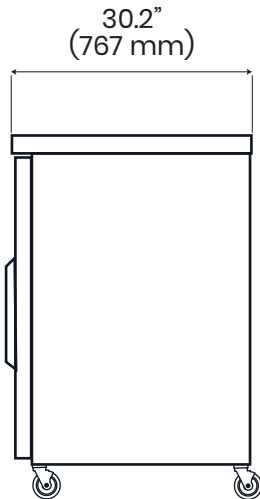

Spec

Electric Data

Voltage	115/60/1
Plug Type	NEMA 5-15P
Compressor HP	1/4
Refrigerant	R290

Dimensional Data

Capacity - cu. ft.	7.8ft ³ (220 liters)
Net Weight - Lbs.	132 Lbs. (60 Kg)

- Slight Variations May Exist



Drago America
www.dragoamerica.com
sales@dragoamerica.com
9777 W. Gulf Bank Road Suite 200, Houston, Texas 77040