



Drago America
www.dragoamerica.com

Project Name: _____

Location: _____

Item #: _____ Qty: _____

Model #: _____

SIA #

AIA #

Model:
DRBB27- 59GH

Coolers – Glass Door Hinged Back Bar Cooler 27” Depth
2 glass door 17 ft³



Features & Benefits

Strong & Durable Structure

- Stainless steel top, interior walls, floor and ceiling.
- Corrosion resistant vinyl on steel in black finish exterior.

Temperature

- Temperature range 33°F~40°F (0°C~4°C).

User Friendly Features

- Self-closing doors with locks.
- Option of stainless steel exterior available.
- LED interior lighting.
- Adjustable heavy duty PVC coated shelves.
- Easy access to condenser coil for cleaning and service.
- Easy adjust temperature set point and defrost frequency.

Pre-installed heavy-duty casters with brakes.

Refrigerant R290.



Certifications



Intertek



Intertek

Doors	Shelves	HP	AMPS	Crated Weight	Dimensions (inches)		
					W	D	H
2	4	3/7	3.5	298 Lb (135 Kg)	60" (1495 mm)	27.8" (705 mm)	35.6" (905 mm)

Packaging dimensions (mm): W 61.2" (1555) x D 30.5" (775) x H 42.1" (1070)

Approvals:

Available At:

Model:
DRBB27- 59GH

Coolers – Glass Door Hinged Back Bar Cooler 27” Depth

2 glass door 17 ft³



Front View

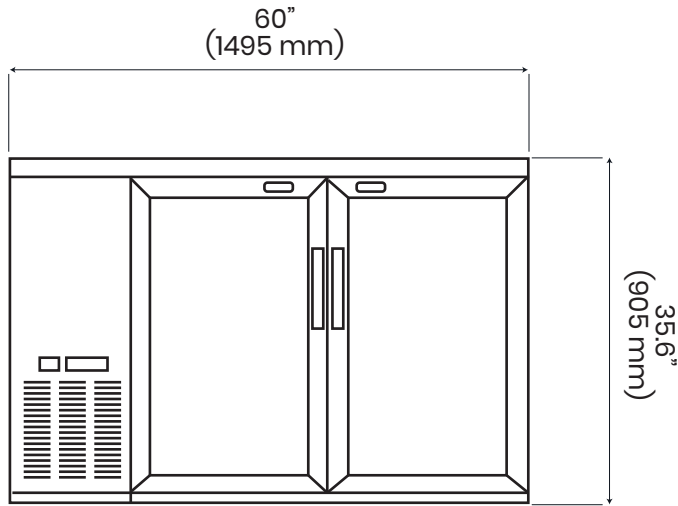

Side View

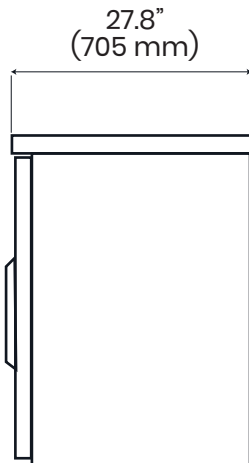

Electric Data

Electric Data	
Voltage	115/60/1
Plug Type	NEMA 5-15P
Compressor HP	3/7
Refrigerant	R290

Dimensional Data

Dimensional Data	
Capacity - cu. ft.	17 ft ³ (480 liters)
Net Weight - Lbs.	253 Lbs. (115 Kg)

- Slight Variations May Exist