



## 2 Door Under Counter Freezer

- NE2F-48UC



### Standard Features

- Stainless steel exterior
- Painted aluminum interior
- Rounded corner design for easy cleanup
- Self closing hinged doors with 90 degree stay open feature
- Programmable electronic control system
- Adjustable, heavy duty PVC coated shelves
- Heavy-duty castor wheels

### Technical Specifications

Product Classification	Freezer
Climate Class	N
Number of Doors	2
External Cabinet Material	430 Stainless Steel
Internal Cabinet Material	Painted Aluminum
Type of Refrigeration Agent	R-290
Type of Temperature Control	Digital
Temperature Range °C	-22°C to -18C
Temperature Range °F	-7°F to 0°F
Voltage / Frequency	115V / 60Hz
Amp	4.5
Compressor HP	1/4+
Type of Insulation	Polyurethane
Handle	Recessed

### Certified Safety Standard

- ETL Listed
- ETL Sanitation Listed



### Warranty Information

- ◆ 5 Years Compressor
- ◆ 1 Year Parts & Labor





## 2 Door Under Counter Freezer •

## NE2F-48UC

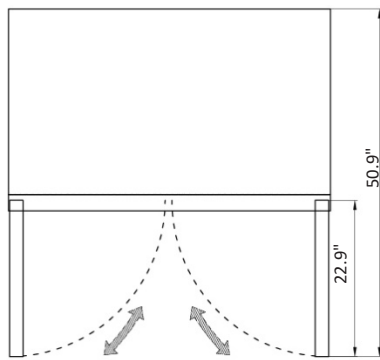

Top Section

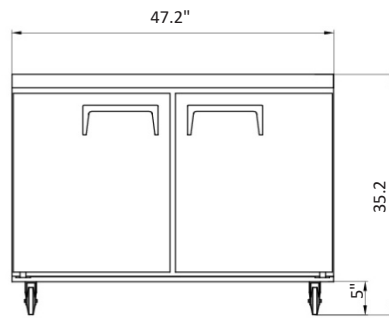

Front View

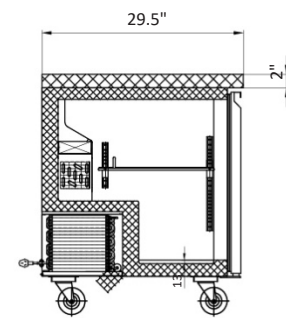

Side Section



Plug Type: (NEMA) 5-15P

### Capacity

Capacity	12 cu. ft.
----------	------------

### Dimensions

Internal Cabinet Width	43 in
Internal Cabinet Depth	23 in
Internal Cabinet Height	24 in
External Width	47 in
External Depth	30 in
External Height	35 in
Shipping Dimensions (W x D x H)	50 x 32 x 38 in

### Weight

Gross Weight	313 lbs.
--------------	----------

### Accessories

Cycle Defrosting	Yes
Frost Free	Yes
Adjustable Shelves	2
Fixed Shelves	No
Internal Light	No
Internal Light Switch	No
External Light Switch	No
Self Closing Door / Lid	Yes
Door Holder for Loading	Yes
Door / Lid Lock	No
Reversable (Left) Door	No
Adjustable Feet	Optional
Adjustable Thermostat	Yes