

72" Undercounter Refrigerator

◆ NE3R-72UC



Standard Features

- Stainless steel exterior
- Painted aluminum interior
- Self closing hinged doors with 90 degree stay open feature
- Programmable electronic control system
- Adjustable, heavy duty PCV coated shelves
- Heavy-duty caster wheels

Technical Specifications

Product Classification	Refrigerator
Climate Class	N
Number of Doors	3
External Cabinet Material	430 Stainless Steel
Internal Cabinet Material	Painted Aluminum
Type of Refrigeration Agent	R-290
Type of Temperature Control	Digital
Temperature Range °C	0°C to 4°C
Temperature Range °F	32°F to 40°F
Voltage / Frequency	115V / 60Hz
Amp	2.7
Compressor HP	1/5
Type of Insulation	Polyurethane
Handle	Recessed

Certified Safety Standard

- ETL Listed
- ETL Sanitation Listed



Warranty Information

- ◆ 5 Years Compressor
- ◆ 1 Year Parts & Labor





72" Undercounter Refrigerator

◆ NE3R-72UC

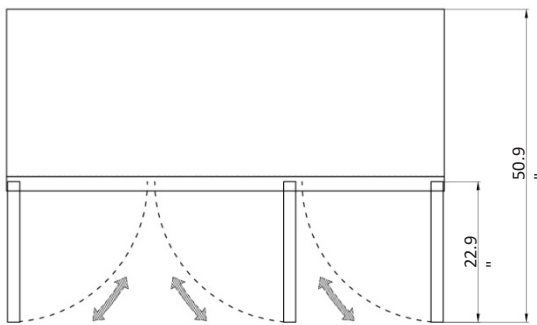

Top Section

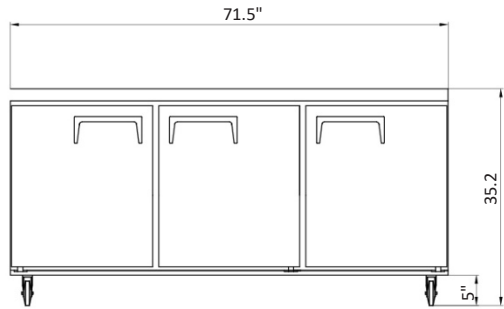

Front View

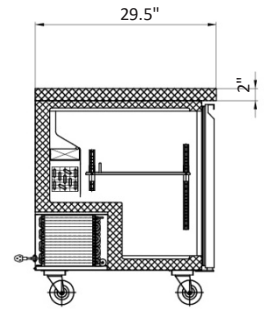

Side Section



Plug Type: (NEMA) 5-15P

Capacity

Gross Capacity cu. ft.

Dimensions

Internal Cabinet Width	67 in
Internal Cabinet Depth	20 in
Internal Cabinet Height	24 in
External Width	72 in
External Depth	30 in
External Height	35 in
Shipping Dimensions (W x D x H)	74 x 32 x 38 in

Weight

Gross Weight 408 lbs.

Accessories

Frost Free	Yes
Adjustable Shelves	3
Fixed Shelves	No
Internal Light	No
Internal Light Switch	No
External Light Switch	No
Self Closing Door / Lid	Yes
Door Holder for Loading	Yes
Door / Lid Lock	No
Reversible (Left) Door	No
Adjustable Feet	Optional
Adjustable Thermostat	Yes