

# Mega-Top Prep Tables

MEGA-TOP PREP TABLES WITH DRAWERS



## BUILT TO PERFORM, DESIGNED TO DELIVER

The Asber APTM Premium Line Prep Tables represent the next generation of professional refrigeration—engineered for greater storage capacity, superior temperature control, and lasting durability. Featuring an exclusive base design that provides over 30% more interior space than most units in their class, these tables maximize usable storage without increasing footprint.

## INSULATION & ENERGY EFFICIENCY

### High Performance, Environmentally Responsible Design

- Ecomate™ insulation: Industry-leading, eco-friendly technology (ODP-0, GWP-3) for exceptional temperature retention and energy savings.
- Maximum thermal efficiency: 2" thick insulation throughout.

## INNOVATIVE AIRFLOW SYSTEM

### Even Cooling for Maximum Food Freshness

- Unique airflow system: Cold air beneath the pans keeps ingredients at ideal temperatures without drying.
- Integrated bottom air panel: Blocks spills and directs airflow to the lower compartment for even cooling.

## REFRIGERATION SYSTEM & PERFORMANCE

### Efficient, Reliable, and Environmentally Friendly

- R290 Hydrocarbon refrigerant: Delivers quicker temperature recovery and lower energy consumption, ensuring environmental responsibility.
- Reversible Condensing Fan Motor: Ensuring optimal airflow, reduced maintenance, and improved long-term efficiency.
- Hermetic compressor system with epoxy-coated evaporator provides long-lasting performance and corrosion resistance operation.
- Electronic controller provides accurate, easy-to-monitor temperature management.
- Temperature range: Maintains 32°F to 41°F in ambient conditions up to 100°F and 65% RH.

## CONSTRUCTION & FEATURES

### Durable, Safe, and Easy to Maintain

- Exclusive base design increases interior capacity by over 30% compared to standard models.
- Field-reversible door offer flexible installation.

- Supplied with 1/6-size pans, 4" deep.
  - 27" model include (1) row 1/9-size pans, 4" deep.
- Accommodates up to 6" deep pans for added flexibility.
- Includes a full-length, removable 10" white Nylamid cutting board, NSF-approved for safe and sanitary food preparation.

## DRAWER SYSTEM & STORAGE FLEXIBILITY

### Heavy-Duty, Hygienic, and Operator-Friendly

- All-stainless-steel drawers: Built for durability and ease of use, providing long-lasting performance in busy kitchen environments.
- Factory-installed stainless-steel drawer kits for maximum flexibility.
- High-strength slides: Designed for smooth operation and dependable support under heavy use, rated for up to 88 pounds per drawer.
- Flexible configurations: Each drawer accommodates pan sizes from 1/9 to 1/1, up to 6" deep (pans sold separately).

## OPERATOR-FOCUSED DESIGN

### Ergonomic, Practical, and Sanitary

- Full-length recessed handles: Provide ergonomic access while maintaining a clean, professional appearance.
- In-step interior design: provides a superior door seal, reducing energy loss, and preventing condensation.
- Magnetic one-piece door gaskets: Ensure a tight seal to preserve internal temperatures; tool-free removable, simplifying cleaning and maintenance.
- Fixed top and drawer pan dividers: ensure stable pan placement, minimize cross-contamination, and keep ingredients neatly organized.
- Standard 5" casters (front with brakes) provide stability, mobility, and easy access for cleaning and maintenance.

## CERTIFICATIONS

- NSF-7 Certified: Meets rigorous food safety and sanitation standards.
- ETL Listed: Certified for electrical and mechanical safety.
- DOE Compliant: Meets U.S. Department of Energy efficiency standards.

## OPTIONS & ACCESSORIES

- Overshelf.
- Extra shelves.
- 3" Casters.
- 6" Stainless-steel legs.



APT M 27 12 D2 P



APT M 48 18 D2 P



APT M 60 24 D4 P

MODEL	DOORS	DRAWERS	CAPACITY		VOLTS - FREQUENCY	POWER		EXTERIOR DIMENSIONS (in)			SHIPPING	
			ft <sup>3</sup>	Pans		HP	AMP	Width	Depth	Height	Lbs	ft <sup>3</sup>
PIZZA PREP TABLES WITH DRAWERS												
APT M 27 12 D2 P	0	2	9.5	3 + 9	115V. - 60Hz.	1/10	1.5	27-3/4	36-1/8	44-5/8	207	35.3
APT M 48 18 D2 P	1	2	16.7	18	115V. - 60Hz.	1/4	2.5	48-3/8	36-1/8	44-5/8	309	56.5
APT M 48 18 D4 P	0	4	16.7	18	115V. - 60Hz.	1/4	2.5	48-3/8	36-1/8	44-5/8	309	56.5
APT M 60 24 D2 P	1	2	20.6	24	115V. - 60Hz.	1/4	2.5	60-3/8	36-1/8	44-5/8	362	70.6
APT M 60 24 D4 P	0	4	20.6	24	115V. - 60Hz.	1/4	2.5	60-3/8	36-1/8	44-5/8	362	70.6
APT M 72 30 D2 P	2	2	25.4	30	115V. - 60Hz.	1/4	2.5	72-1/2	36-1/8	44-5/8	419	84.8
APT M 72 30 D4 P	1	4	25.4	30	115V. - 60Hz.	1/4	2.5	72-1/2	36-1/8	44-5/8	419	84.8
APT M 72 30 D6 P	0	6	25.4	30	115V. - 60Hz.	1/4	2.5	72-1/2	36-1/8	44-5/8	419	84.8

SPECIFICATIONS ARE SUBJECT TO CHANGE WITHOUT PRIOR NOTICE. | HEIGHT INCLUDES 6" CASTERS. | VALID ONLY FOR CONTINENTAL USA & CANADA.

# Mega-Top Prep Tables

MEGA-TOP PREP TABLES WITH DRAWERS



APTM 27 12 D2 P

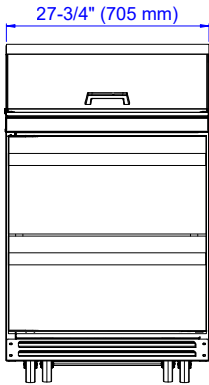

APTM 48 18 D4 P

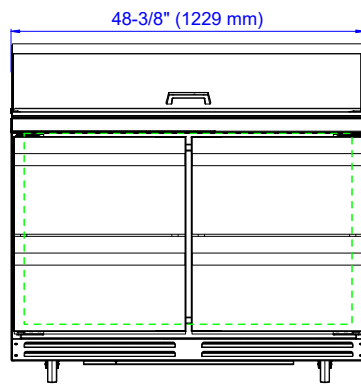

APTM 60 24 D4 P

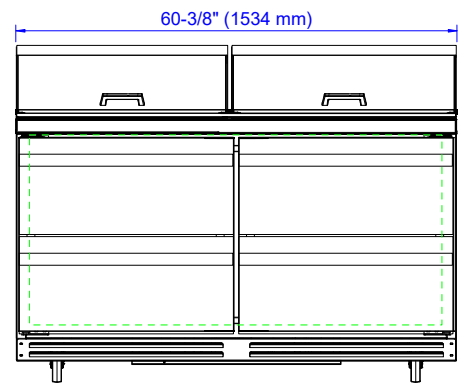

APTM 72 30 D6 P

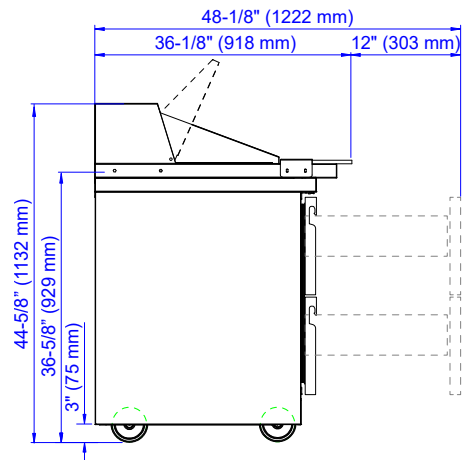
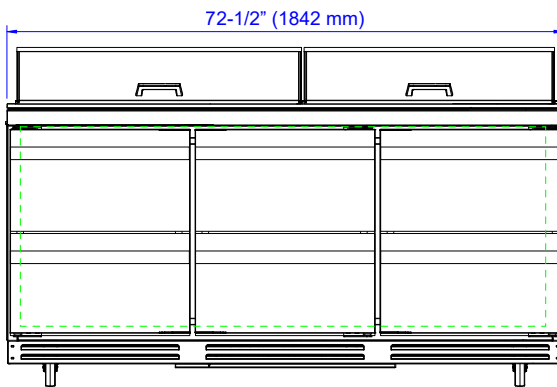

MODEL	APTM 27 12 D2 P	APTM 48 18 D4 P	APTM 60 24 D4 P	APTM 72 30 D6 P
<b>ELECTRICAL DATA</b>				
Volts - Frequency	115V. - 60Hz.			
Power (HP)	1/10		1/4	
Full Amp Load	1.5		2.5	
Plug Type	NEMA 5-15P			
Refrigerant	R290			
<b>SHIPPING DIMENSIONS (in)</b>				
Width	31-1/2	52	64-1/8	76
Depth	37-3/4			
Height	51-1/8			



## INSTALLATION REQUIREMENTS

- ELECTRICAL CONNECTION:** Units pre-wired at factory with chord and NEMA 5-15P plug set included for 115/60/1 phase.
- REFRIGERANT:** R290 is classified as A3 flammable refrigerant; risk of fire or explosion due to puncture of refrigerant tubing; follow handling instructions carefully.
- RESIDENTIAL APPLICATIONS DISCLAIMER:** Asber assumes no liability for parts or labor coverage for component failure, factory defect or any other damages for units installed in non-commercial foodservice or residential applications.

SPECIFICATIONS ARE SUBJECT TO CHANGE WITHOUT PRIOR NOTICE. | HEIGHT INCLUDES 6" CASTERS. | VALID ONLY FOR CONTINENTAL USA & CANADA.