

Pizza Prep Tables

PIZZA PREP TABLES WITH DOORS



BUILT TO PERFORM, DESIGNED TO DELIVER

The Asber APTP Series Prep Tables enhance performance, hygiene, and efficiency in any pro kitchen. An advanced airflow system delivers uniform cooling, while eco-friendly R290 refrigeration maximizes energy savings. With a full-length Nylamid cutting board, digital controller, and roll-ready capacity for full-size sheet pans, Asber Pizza Prep Tables offer a versatile, high-capacity solution built for fast-paced pizza and foodservice operations.

INSULATION & ENERGY EFFICIENCY

High Performance, Environmentally Responsible Design

- Ecomate™ insulation: Industry-leading, eco-friendly technology (ODP-0, GWP-3) for exceptional temperature retention and energy savings.
- Maximum thermal efficiency: 2" thick insulation throughout.
- Insulated lid keeps ingredients colder longer, cutting energy use and ensuring peak freshness through every rush.

INNOVATIVE AIRFLOW SYSTEM

Even Cooling for Maximum Food Freshness

- Unique airflow system: Cold air beneath the pans keeps ingredients at ideal temperatures without drying.
- Integrated bottom air panel: Blocks spills and directs airflow to the lower compartment for even cooling.

REFRIGERATION SYSTEM & PERFORMANCE

Efficient, Reliable, and Environmentally Friendly

- R290 Hydrocarbon refrigerant: Delivers quicker temperature recovery and lower energy consumption, ensuring environmental responsibility.
- Reversible Condensing Fan Motor: Ensuring optimal airflow, reduced maintenance, and improved long-term efficiency.
- Hermetic compressor system with epoxy-coated evaporator provides long-lasting performance and corrosion resistance operation.
- Electronic controller with digital display provides accurate, easy-to-monitor temperature management.
- Temperature range: Maintains 32°F to 41°F in ambient conditions up to 100°F and 65% RH.

CONSTRUCTION & FEATURES

Durable, Safe, and Easy to Maintain

- Exclusive base design increases interior capacity by over 30% compared to standard models.

- Accepts standard 18" x 26" sheet pans, providing flexible storage options for busy commercial kitchens (except 17 ft3 and 37 ft³).
- Supplied with 1/3-size pans, 6" deep.
- Includes a full-length, removable 19" white Nylamid cutting board, NSF-approved for safe and sanitary food preparation.

DRAWER SYSTEM & STORAGE FLEXIBILITY

Heavy-Duty, Hygienic, and Operator-Friendly

- Field-convertible stainless-steel drawer kits for maximum flexibility.
- All-stainless-steel drawers: Built for durability and ease of use, providing long-lasting performance in busy kitchen environments.
- High-strength slides: Designed for smooth operation and dependable support under heavy use, rated for up to 110 pounds per drawer.
- Flexible configurations: Each drawer accommodates pan sizes from 1/9 to 1/1, up to 6" deep (pans sold separately).

OPERATOR-FOCUSED DESIGN

Ergonomic, Practical, and Sanitary

- Full-length recessed handles: Provide ergonomic access while maintaining a clean, professional appearance.
- In-step interior design: provides a superior door seal, reducing energy loss, and preventing condensation.
- Magnetic one-piece door gaskets: Ensure a tight seal to preserve internal temperatures; tool-free removable, simplifying cleaning and maintenance.
- Fixed top and drawer pan dividers: ensure stable pan placement, minimize cross-contamination, and keep ingredients neatly organized.
- Standard 5" casters (front with brakes) provide stability, mobility, and easy access for cleaning and maintenance.

CERTIFICATIONS

- NSF-7 Certified: Meets rigorous food safety and sanitation standards.
- ETL Listed: Certified for electrical and mechanical safety.
- DOE Compliant: Meets U.S. Department of Energy efficiency standards.

OPTIONS & ACCESSORIES

- Overshelf.
- Extra shelves.
- Garnish racks.
- 3" Casters.
- 6" Stainless-steel legs.



APTP 46



APTP 67



APTP 93

MODEL	DOORS	SHELVES	CAPACITY		VOLTS - FREQUENCY	POWER HP	AMP	EXTERIOR DIMENSIONS (in)			SHIPPING	
			ft ³	Pans				Width	Depth	Height	Lbs	ft ³
PIZZA PREP TABLES WITH DOORS												
APTP 46	1	2	11.6	6	115V. - 60Hz.	1/3	3.0	46-1/4	36-1/8	57	333	45.9
APTP 67	2	4	20.8	9	115V. - 60Hz.	1/3	3.0	67-1/2	36-1/8	57	437	67.1
APTP 93	3	6	30.2	12	115V. - 60Hz.	1/3	3.0	93-3/4	36-1/8	57	578	91.8

SPECIFICATIONS ARE SUBJECT TO CHANGE WITHOUT PRIOR NOTICE. | HEIGHT INCLUDES 6" CASTERS. | VALID ONLY FOR CONTINENTAL USA & CANADA.

Pizza Prep Tables

PIZZA PREP TABLES WITH DOORS

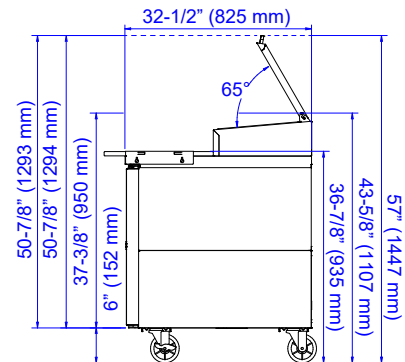
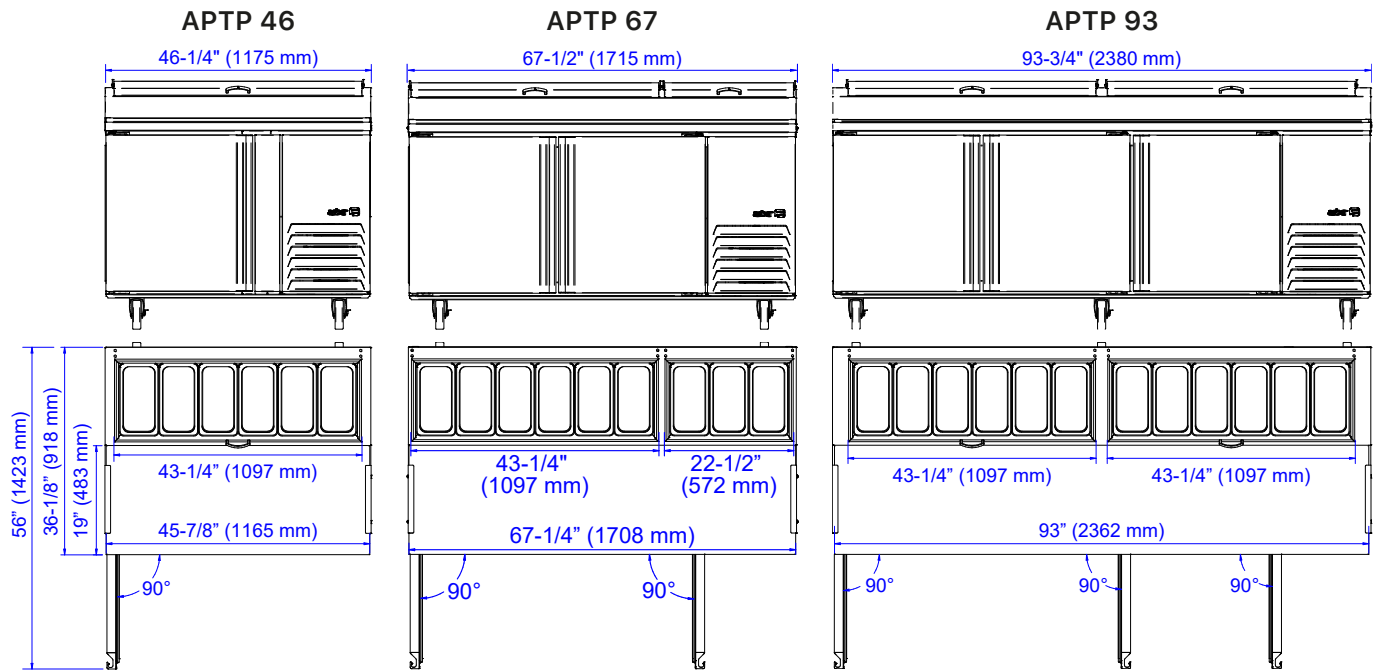

MODEL	APTP 46 D2	APTP 67 D4	APTP 93 D6
ELECTRICAL DATA			
Volts - Frequency	115V. - 60Hz.		
Power (HP)	1/3		
Full Amp Load	3.0		
Plug Type	NEMA 5-15P		
Refrigerant	R290		
INTERIOR DIMENSIONS (in)			
Width	27-1/8	48-3/8	74-5/8
Depth	25-5/8		
Height	24-3/4		
Shelf (in)	21-1/8 x 26		
SHIPPING DIMENSIONS (in)			
Width	48-7/8	70-1/8	96-1/8
Depth	36-1/4		
Height	45-5/8		



INSTALLATION REQUIREMENTS

- ELECTRICAL CONNECTION:** Units pre-wired at factory with chord and NEMA 5-15P plug set included for 115/60/1 phase.
- REFRIGERANT:** R290 is classified as A3 flammable refrigerant; risk of fire or explosion due to puncture of refrigerant tubing; follow handling instructions carefully.
- RESIDENTIAL APPLICATIONS DISCLAIMER:** Asber assumes no liability for parts or labor coverage for component failure, factory defect or any other damages for units installed in non-commercial foodservice or residential applications.

SPECIFICATIONS ARE SUBJECT TO CHANGE WITHOUT PRIOR NOTICE. | HEIGHT INCLUDES 6" CASTERS. | VALID ONLY FOR CONTINENTAL USA & CANADA.