

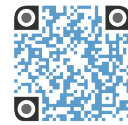

F1A-HG

One Section Half Glass Door Freezer



F1A-HG
09/28/22
Item # 13530

W x D x H

27.5" x 34.5" x 79.5"*
*with 4" casters



Item #: _____

Project: _____

Qty: _____

AIA#: _____

Features

- ▶ **Maximum interior storage capacity with smallest external footprint**
- ▶ **Stainless steel interior with stainless steel exterior front, sides and top**
- ▶ **Unique ducted air distribution system**
 - Energy efficient interior LED light
 - Environmentally friendly R290 hydrocarbon refrigerant
 - Solid state digital controller with temperature alarms and LED display (Fahrenheit or Celsius)
 - Cabinet and doors are insulated with 2-3/8" of CFC free, foamed in place polyurethane
 - Glass doors are energy efficient multi pane, argon filled with locks
 - Stainless steel exterior and interior door come standard with locks
 - Exclusive stepped door design to protect recessed door gasket
 - Self-closing doors with stay open feature
 - One piece, full length, chrome handle
 - Sturdy 8 gauge stainless steel hinge plate with welded hinge pin
 - Extruded aluminum flush mount door handle
 - Field reversible doors
 - Evaporator coils are epoxy electrocoated (E-Coat) to help fight corrosion
 - Energy efficient automatic hot gas condensate evaporator
 - Top mount refrigeration comes standard with a condenser filter
 - Refrigerant flow is controlled with thermostatic expansion valve
 - Stainless steel shelf supports
 - (3) epoxy coated wire shelves are standard
 - Standard with 4" casters (two with brakes)
 - Stackable (two units high) to conserve warehouse floor space
 - 10 ft. cord and plug



Dimensions / Capacity

Interior Storage Capacity (CF) (AHAM)

One Section F1A-HG

23.10 ft³

Overall Width x Depth

27.5" x 34.5"

Height (including 4" casters)

79.5"

Door Opening Width x Height

21.75" x 27.75"

Depth with Door Open at 90°

57"

Adjustable Shelves

3

Shelf Dimensions (W x D)

21.25" x 26"

Crated Shipping Weight

365 lbs

Crated Length x Depth x Height

37.5" x 31.5" x 81"

Electrical / Refrigeration

Voltage

115/60/1

HACR Breaker

15.0 Amps

Electrical Connection (NEMA)

5-15P

Voltage Range

104-126

Ambient Temp. Range

45° to 80°F

Control Setpoint Range

-10° to +12°F

Amperage

8.5

Energy Consumption (kWh/day) @ASHRAE

7.73

Heat Rejection (BTU/Hr.) @NSF

806

Approx. Nominal Compres. BTU/HR (HP)

1425(3/4HP)

Refrigerant / Charge Amount (oz)

R290 / (4.1 oz)

Options

- Additional epoxy shelves
- 6" Adjustable legs
- Stainless steel shelves
- Condensate pan (HS-5462)
- Tray/Pan slides

Warranty

3 Year - parts and Labor on entire machine.
5 Year - Parts on Compressor
Valid in United States, Canada, Puerto Rico and U.S. Territories. Contact factory for warranty in other countries.

Hoshizaki reserves the right to change specifications without notice.



F1A-HG

One Section Half Glass Door Freezer



F1A-HG
09/28/22
Item # 13530

FRONT VIEW

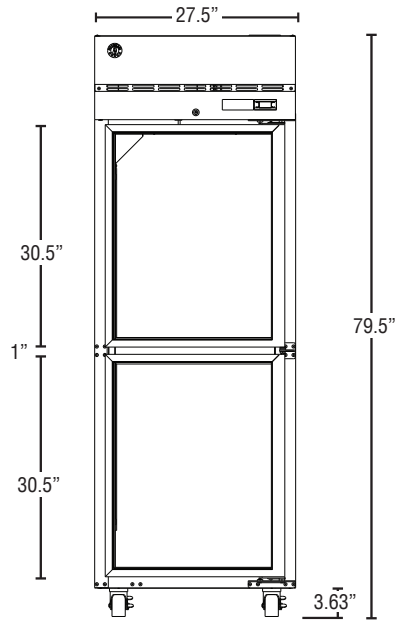

SIDE VIEW

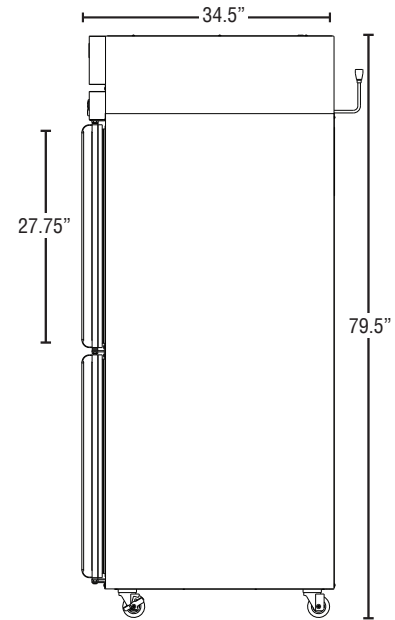

PLAN VIEW

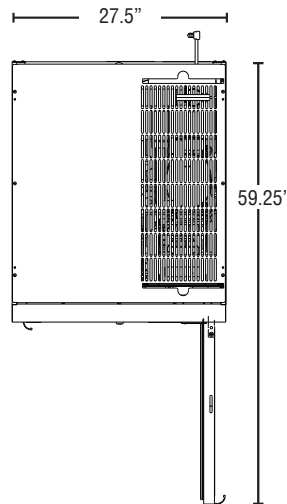

Cabinet Construction

The exterior cabinet front, sides, and top are constructed of high quality stainless steel. The exterior back, and bottom are constructed of coated steel. The cabinet interior is constructed of stainless steel with a unique ducted air flow system. Three (3) heavy duty epoxy coated shelves per section are standard. Mounted on stainless steel pilasters shelves are adjustable in 1" increments. Cabinet walls and doors are insulated with 2-3/8" of environmentally friendly, CFC free, foamed in place polyurethane. Perimeter and mullion heaters prevent condensation from forming on the face of the cabinet. Two interior LED light strips are mounted vertically and controlled by a separate switch on the controller. 4" polyolefin, casters (two with brakes) are standard.

Door Construction

Glass doors are constructed of high grade silver anodized aluminum with a full length chrome handle. Door glass is energy efficient multi pane, argon filled with locks. The door hinges are all metal and include an adjustable torsion spring closure that will not wear out like traditional cam-lift hinges. Hinge plates are constructed of heavy duty stainless steel. Doors stay open at 90° and are self-closing at 75°. Snap-in magnetic door gaskets are durable and easily removed for cleaning. Door hinging is field reversible.

Refrigeration System

The high efficiency refrigeration system is self-contained with an epoxy electrocoated (E-Coat) evaporator for extended life. Top mounted refrigeration system is easily accessible for service and includes a condenser filter with easy access from the top of the unit. The refrigeration system components are assembled on a high density expanded polypropylene platform that is removable from the main unit. A unique ducted air flow system achieves uniform air distribution within the cabinet to eliminate hot spots. Condensate removal is accomplished with a top mounted energy efficient non-electric evaporation system. A thermostatic expansion valve (TXV) controls the flow of environmentally friendly R290 refrigerant through the evaporator. Refrigeration system utilizes a time initiated heated defrost to eliminate any ice on the evaporator coil. Solid state digital controls monitor the operation and performance of the refrigeration system. The controls also provide visual high and low temperature and high and low voltage alarms. A LED display shows the cabinet temperature and is adjustable to Fahrenheit or Celsius. 115 volt units are equipped with a ten foot cord and plug (20.0 amps or less).