



SPEC SHEET

47 in. Commercial 2-Glass Door Merchandiser Refrigerator, 29 Cu. Ft. in White

Model: KM-MDR-2GD-47

FEATURES

- **Spacious Storage:** 29 Cu. Ft. with eight adjustable, plastic-coated steel shelves (99 lbs. capacity each) for versatile organization.
- **Double Glass Doors:** Dual-pane, LOW-E tempered glass swing doors for superior insulation and product visibility.
- **Precise Temperature Control:** Digital thermostat maintains 34°F to 50°F for optimal storage of beverages, dairy, and perishables.
- **Energy-Efficient:** 0.42 HP bottom-mounted compressor uses 1270 KWH/year, minimizing costs and environmental impact.
- **Bright LED Lighting:** 18.6W middle beam LED enhances product visibility with energy-efficient illumination.
- **Durable Build:** Painted steel exterior and interior for a sleek, low-maintenance design suited for commercial use.
- **Convenient Mobility:** Four casters for easy movement, plus adjustable legs for stability on uneven floors; fits tight spaces with 26-inch depth.
- **Secure Storage:** Built-in safety lock protects inventory when not in use.
- **Wide Temperature Tolerance:** Operates effectively in ambient temperatures up to 100°F, ideal for various commercial settings.
- **Certified & Warranted:** ETL certified with a 1-year parts and labor warranty for reliable performance and support.



CLOSE UP IMAGES



Technical Specs

Dimensions & Weight

Length	32 in.
Width	25.94 in.
Height	79.37 in.
Weight	290 lbs
Interior Depth	20.87 in.
Interior Width	43.31 in.
Interior Height	52.17 in.
Shelf Depth	18.6 in.
Shelf Width	20.9 in.
Depth Excluding Handles	24.96 in.
Depth Including Handles	26.61 in.
Depth Less Door	22.72 in.
Depth with Door Open 90°	46.34 in.
Minimum Back Air Clearance	20 in.
Minimum Side Air Clearance	20 in.

Electric & Certifications

Certifications	ETL Listed for Safety and Sanitation
Amps	4
Hertz	60
Phase	1
Voltage	115
Wattage	460
Plug Type	NEMA 5-15P
Power Cord Length	66 in.
Energy Consumption Per Year	1270.2 KWH/year
Electrical Installation Type	Plug-in

Capacity

Gross Cubic Feet	29.49
Net Cubic Feet	29.06
Number of Shelves	8
Individual Shelf Capacity	99 lbs
Temperature Range	34–50 F
Ambient Temperature Range	100 F

Features & Materials

Defrost Type	No Frost
Refrigerant Type	R-290
Horsepower	0.42
Number of Doors	2
Door Style	Swing
Interior Lights	LED
Interior Lights Color	White
Interior Lights Brightness	18.6W
Control Type	Digital
Color Door Handles	White
Shelf Material Type	Plastic-coated steel
Shelves Adjustable	Yes
Interior Color	White
Interior Material	Prepainted Steel
Exterior Material	Prepainted Steel
Noise	62 dB
Legs Adjustable	Yes
Casters	4
Safety Lock	Yes

Plan View

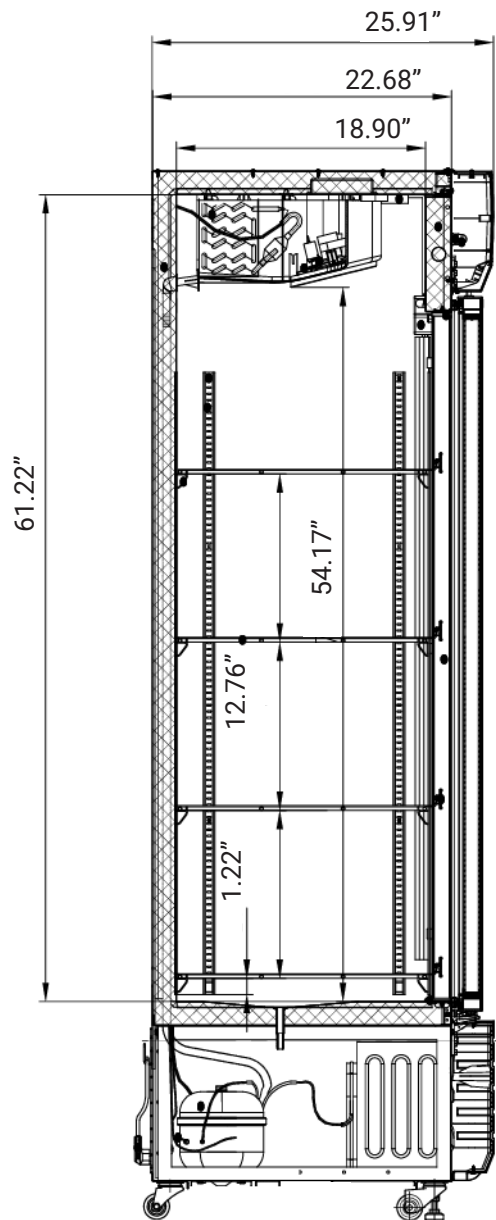
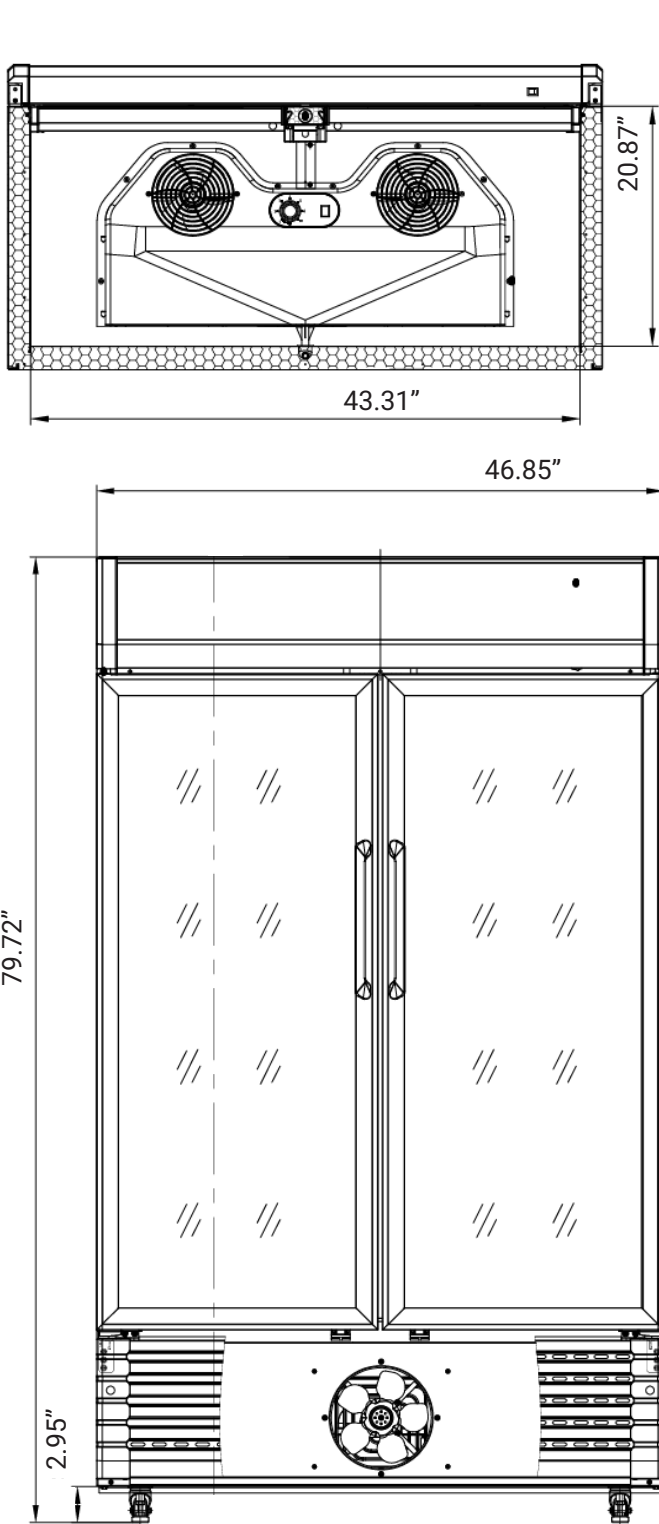

CERTIFICATIONS



718-576-6342
info@koolmore.com