

ESTABLISHING A NEW STANDARD IN THE COMERCIAL REFRIGERATION INDUSTRY

Energy efficient, eco-friendly HC refrigerant with low charge, spark-free components, and the lowest utility costs in its category

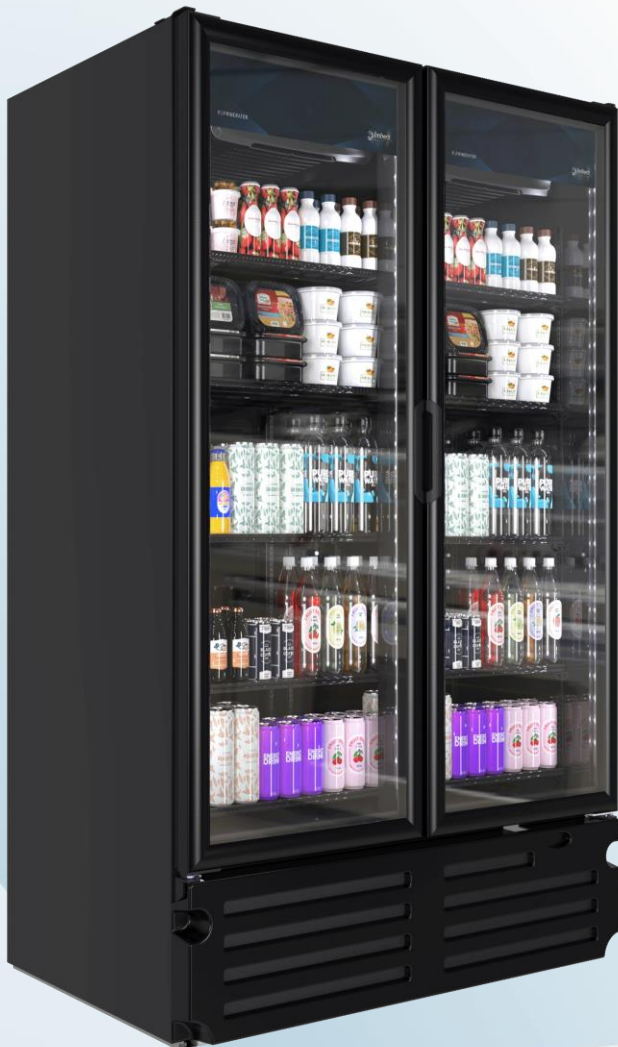

KEY FEATURES



ECO-FRIENDLY HC NATURAL REFRIGERANT

New R290 HFC-free refrigerant gas that reduces environmental impact and increases efficiency.



NEWLY DESIGNED CONDENSER

New condenser featuring a joints reduction down to zero increasing long term refrigeration reliability and safeguarding against any system leaks.



ELECTRONIC TEMPERATURE CONTROLLER

Electronic controller assures optimal refrigeration performance through precision temperature control, and intelligent control for defrost cycle, compressor & other component functions.



ELECTRONIC FAN MOTORS

Enhances performance and efficiency. Uses only a fraction of the energy and offers longer life expectancy than industry standard shaded-pole motors.

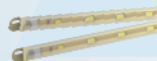

LED Efficiency +220 LUX

Minimum Output
New 5th generation constant power ultra-high efficiency LED uses lowest energy possible, with highest light output.



Spark-free refrigeration components

All HC models will have spark free refrigeration components for optimal safety, per UL requirements

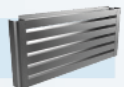

PRE PAINTED STEEL FRONT SHELF

Pre-Painted Steel Will prevent the shelf discoloring over time, as well as provide a sleek, consistent appearance to the equipment.

TECHNICAL SPECIFICATIONS

Exterior dimensions	Internal dimensions	Usable interior capacity
H: 79 3/8" (201 cm)	H: 59 5/8" (151cm)	H: 52 1/2" (133cm)
W: 54 1/4" (138cm)	W: 50 1/8" (127cm)	W: 47 1/2" (120cm)
D: 31 1/2" (80cm)	D: 24 7/8" (63cm)	D: 19 1/8" (49cm)

Usable volume	27.64 ft ³ (782.90 lts)
Doors	2
Door construction	Plastic frame
Shelves	10
Shelf size	W: 24 1/4" (61cm) D: 19 3/4" (50.2cm)
External material	Pre-painted steel
Internal material	Pre-painted steel

DATA CAPACITY**

20 oz bottle capacity

Total:	560
Facings per shelf:	8
Total facings:	80

12 oz can capacity

Total:	1260
Facings per shelf:	18
Total facings:	180

REFRIGERATION PERFORMANCE DATA

Refrigerant	R290	3.4 oz (0.095kg)
Energy consumption	4.680 kwh / 24 h	
Compressor power	1/4 HP	365 watts
Condenser	Dynamic	
Thermostat setting default	Cut-out 44.6°F (7°C)	Cut-in 32°F (0°C)

ELECTRICAL DATA

Power supply	115 / 60 Hz	
Amps	6.6 A	
Length of cord	128.7" (327 cm)	
Lighting	6 modules	144 total LED'S
Plug type	B	
Controller	ETC1H	

LOGISTIC DATA

Trailer loads	20': 11
	40': 22
	53': 30
Unit weight w/packaging	H: 82 1/2" (209cm)
Dimensions w/packaging	W: 56 3/8" (143cm)
	D: 31 5/8" (80cm)

PRODUCT VIEWS

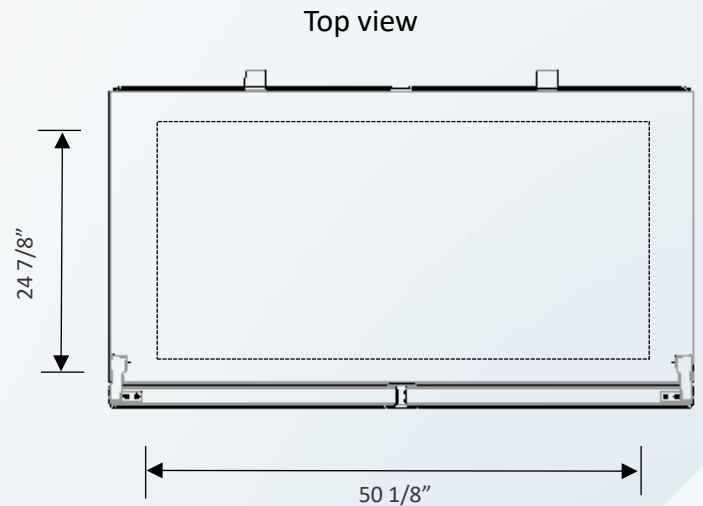
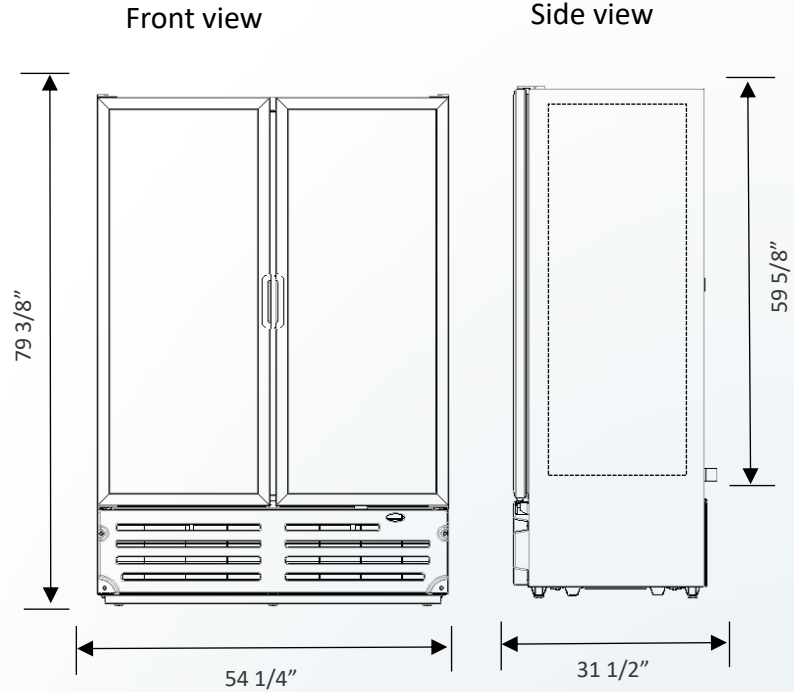

- *Energy consumption based on C condition
- *BMAD System (Low maintenance high performance)
- *Dimensions rounded up to the nearest inch or millimeter
- *Specifications subject to change without notice
- *H: Height, W: Width, D: Depth
- **Product capacity expressed at its highest level

Customer service and warranty
Operators must follow installation and operational guidelines per Imbera Users Manual
Each cooler must be connected directly to a single power supply, otherwise warranty will be voided

11/12/2024