

ESTABLISHING A NEW STANDARD IN THE COMMERCIAL REFRIGERATION INDUSTRY

Energy efficient, environmentally friendly, featuring spark-free components, low refrigerant charge and the most attractive product display.

**KEY FEATURES****ECO-FRIENDLY HC NATURAL REFRIGERANT**

New R290 HFC-free refrigerant gas that reduces environmental impact and increases efficiency.

**NEWLY DESIGNED CONDENSER**

New condenser featuring a joint reduction down to zero increasing long term refrigeration reliability and safeguarding against any system leaks.

**ELECTRONIC TEMPERATURE CONTROLLER**

Electronic controller assures optimal refrigeration performance through precision temperature control, and intelligent control for defrost cycle, compressor & other component functions.

**ELECTRONIC FAN MOTORS**

Enhances performance and efficiency. Uses only a fraction of the energy and offers longer life expectancy than industry standard shaded-pole motors.

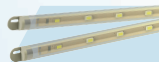
**LED EFFICIENCY +220 LUX MINIMUM OUTPUT**

New 5th generation constant power ultra-high efficiency LED uses lowest energy possible, with highest light output.

**SPARK-FREE REFRIGERATION COMPONENTS**

All HC models will have spark free refrigeration components for optimal safety, per UL requirements.

TECHNICAL SPECIFICATIONS

Exterior dimensions	Internal dimensions	Usable interior capacity
H: 60 7/8"	H: 43 5/8"	H: 39 3/4"
W: 39 1/8"	W: 36 1/8"	W: 34 1/8"
D: 24 1/2"	D: 15 5/8"	D: 14 1/8"

Usable volume	20.97 ft ³
Doors	2
Door construction	Plastic frame
Shelves	4
Shelf size	W: 34 1/8" D: 14 1/8"
External material	Pre-painted steel
Internal material	Pre-painted steel

CAPACITY DATA**

20 oz bottle capacity	
Total:	220
Facings per shelf:	11
Total facings:	44

REFRIGERATION PERFORMANCE DATA

Refrigerant	R290 2.3oz	
Energy consumption	1.830 kwh / 24 h	
Compressor power	1/3 HP 233 watts	
Condenser	Dynamic	
Thermostat setting default	Cut-out 32°F	Cut-in 44.6°F

ELECTRICAL DATA

Power supply	115V / 60 Hz
Amps	4.8
Length of cord	118"
Lighting	10 modules 80 total LED's
Plug type 	NEMA 5-15P
Controller	ETC1H

LOGISTIC DATA

Trailer loads	20': 17 40': 39 53': 50
Unit weight w/packaging	253.97 lb
Dimensions w/packaging	H: 62 7/8" W: 41 3/4" D: 26 3/4"

PRODUCT VIEWS

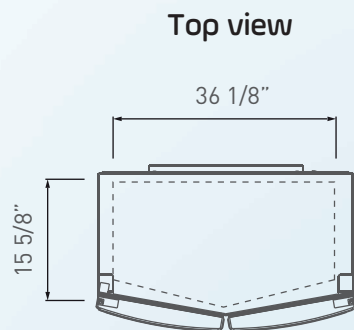
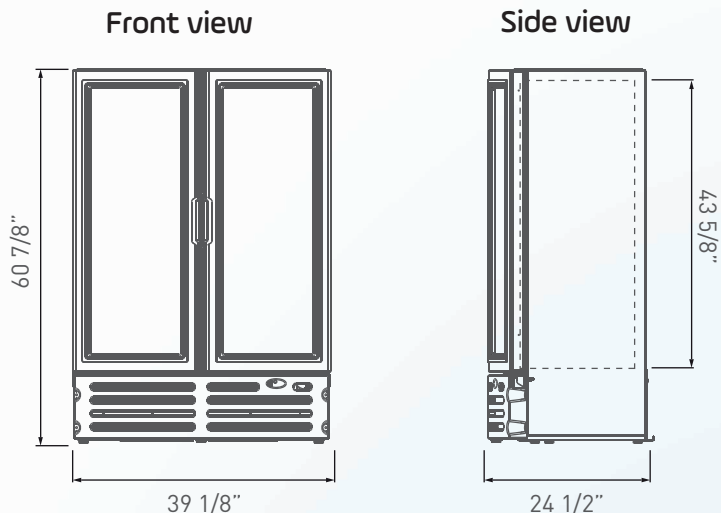

*Energy consumption based on C condition
 *BMAD System (Low maintenance high performance)
 *Dimensions rounded up to the nearest inch or millimeter
 *Specifications subject to change without notice
 *H: Height, W: Width, D: Depth
 **Product capacity expressed at its highest level

Customer service and warranty

Operators must follow installation and operational guidelines per Imbera Users Manual
 Each cooler must be connected directly to a single power supply, otherwise warranty will be voided

01/21/2022