



# SLICER12G

Slicer 12"

Meat Gear SLICER 12G Commercial Meat Slicer.



The SLICER12G Gear-Driven Meat Slicers are engineered for precision slicing of cold cuts and boneless frozen red meats. Designed for demanding, high-volume environments, this slicer deliver powerful, consistent performance for restaurants, hotels, supermarkets, and food processing facilities. The heavy-duty construction and gear-driven transmission ensure reliable operation, accurate slicing, and long-term durability in commercial foodservice applications.



## STANDARD FEATURES

- Heavy Duty Anodized Aluminum Construction.
- 12" Chromium Steel Blade
- Powerful 1/2 HP Motor
- Gear Drive Transmission
- 430 RPM
- Adjustable Slice Thickness 0.008 - 0.59 in
- Integrated Blade Sharpener
- Start/Stop Switch



**Compact Design**

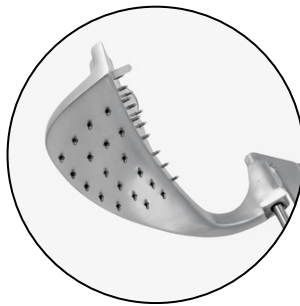

**Weight for Slicing**



**Integrated Balde  
Sharpeners**



**ON/OFF**



SLICER12G

Slicer 12"

## Details and Dimensions

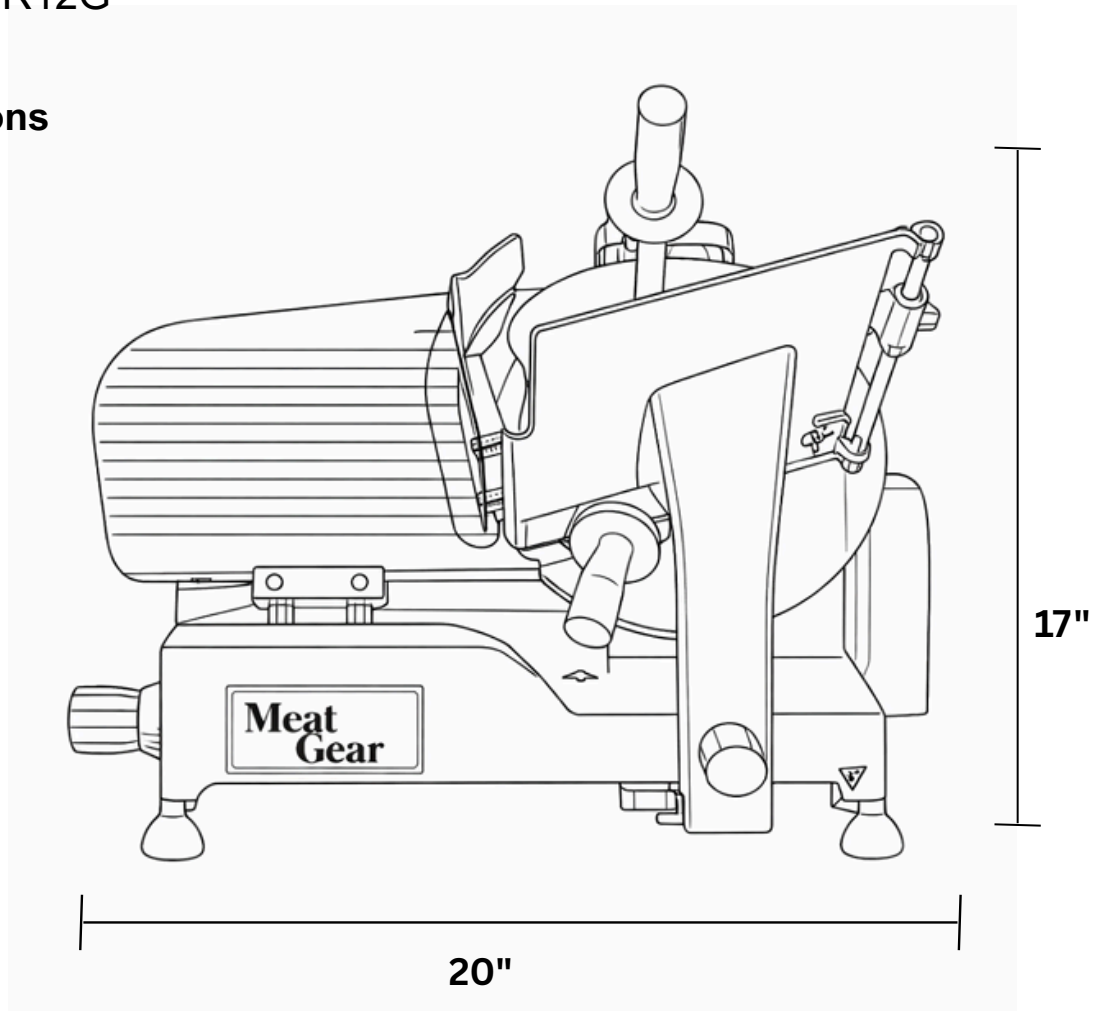

## Technical Specifications

**Electrical:** 120 Volts, 60 Hz and a Single Phase.

**Motor:** 1/2 HP Motor

**Blade Diameter:** 12" Blade

**Transmission:** Gear Driven Transmission

**Finish:** Anodized Aluminium

**Warranty:** Meat Gear 1-Year Warranty, Parts and Labor.

**Weight:**  
**Unit Net:**  
**Shipping:**

**Dimensions: L x W x H**  
**Unit:** 26" x 21.1" x 20.7"  
**Shipping:** 31" x 26" x 24"

## Attributes - Advantages

### Performance:

- Durable, corrosion resistant body designed for long service.
- Powerful 1/2 HP Motor with a 12".
- High-Torque Gear system that ensures consistent power delivery.
- Optimized blade speed to 430 RPM.

### Ease of Operation:

- Built-in Sharpener.
- Easy slice thickness adjustment that allows operators to customize cuts while minimizing product waste.

### Smart Control / Safety

- Simple and reliable operation for daily commercial use.