



VACTUM155

Vacuum Tumbler

Maximize flavor, texture, and yield with the VACTUM155 —our 155 lbs (120 L) vacuum tumbler built for high-capacity food processing. The powerful 3/4 HP vacuum pump boosts marinade absorption and protein activation for superior product quality. Its chain-driven stainless steel drum handles larger loads with consistent, efficient tumbling. With advanced safety features, and easy unloading, it's the ideal solution for streamlined, professional-grade meat preparation.

STANDARD FEATURES

- 1/4 Reduction Motor - 120v -60 Hz
- 155 lbs capacity
- 120 lts capacity
- 3/4 Vacuum Pump with 7 CFM
- Chain Transmission System
- Structure made of steel with stainless steel tumbler
- Vacuum hose micro-switch to prevent accidental start
- Electrical and mechanical safety system (standby electric system)
- Vacuum System with Liquid Trap and Filter
- Marination Timer with End of Cycle Alarm
- Reversible Rotation Function
- Lockable caster wheels

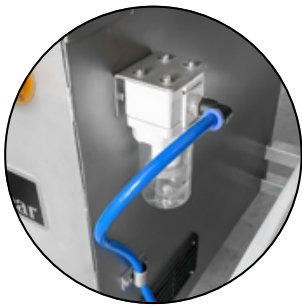

Liquid trap and Filter



Connection Valve to Pump



Standby Electric Features



Casters for Easy Transportation

OPTIONS:

- Unload Cart Dolley



VACTUM155

Vacuum Tumbler

Details and Dimensions

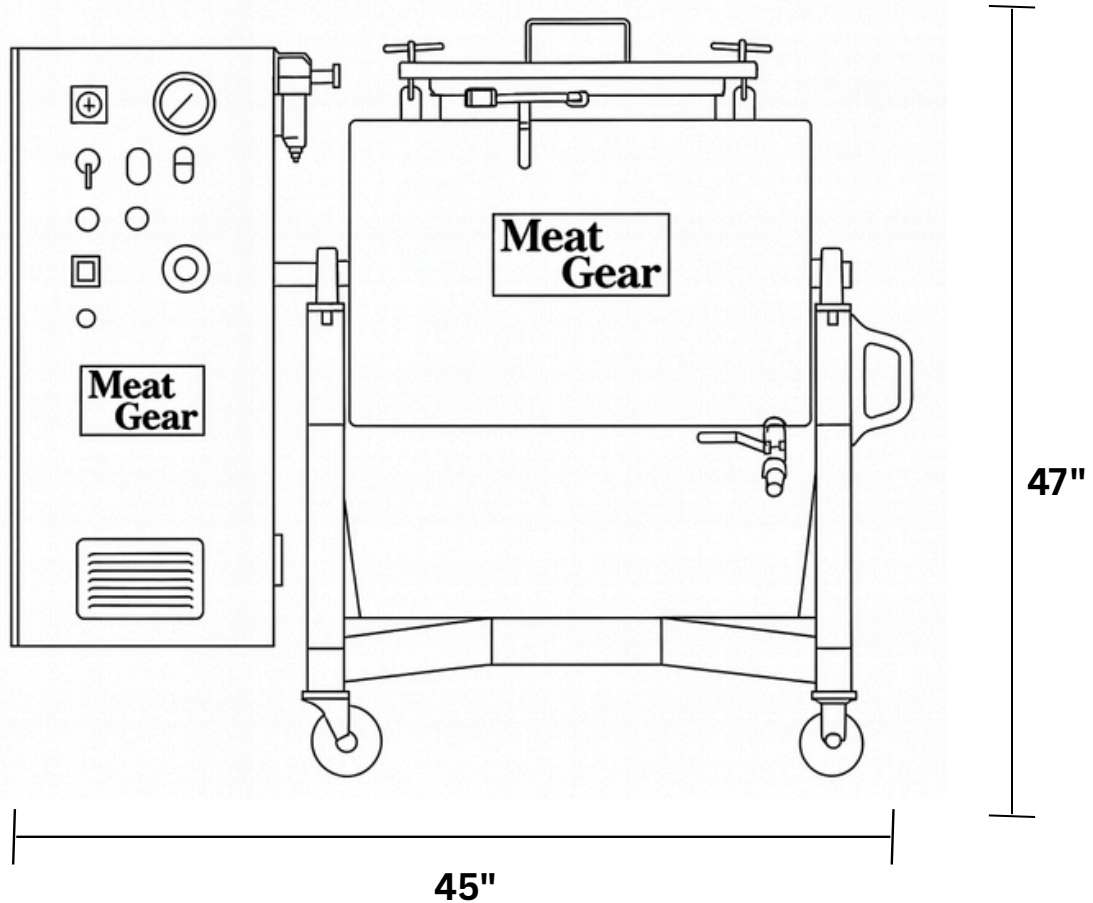

Technical Specifications

Electrical: 120 Volts, 60 Hz and a Single Phase.

Motor: 1/4 Reduction Motor, 3/4 HP Vacuum Pump.

Control Panel: Located in front of the Meat Mixer.

Cord & Plug: A 6 foot flexible 3-wire cord is included with NEMA 5-15 Plug.

Transmission: Chain Transmission

Capacity: 155 lb Tumbling Capacity.

Finish: Steel construction frame and stainless steel tumbler

Warranty: Meat Gear 1-Year Warranty, Parts and Labor.

Weight:

Unit Net: 350 lb

Shipping: 360 lb

Dimensions: L x W x H

Unit: 45" x 26" x 47"

Shipping: 61" x 35" x 53"

Attributes - Advantages

Performance:

- Heavy duty chain transmission, ideal for heavier loads and continuous operation.
- 3/4 HP Vacuum Pump with 7 CFM, delivering powerful vacuum performance for fast, deep marination and uniform product quality.

Ease of Operation:

- Marination Timer to set precise times for consistent product results
- Includes standby electric features for safer, more reliable operation.
- Reversible Rotation, gentle or faster tumbling based on product type.

Smart Control / Safety

- Vacuum System with Liquid Trap, maintains the vacuum pump integrity and cleanliness by capturing fluids.