

REFRIGERATED 40" DISPLAY CASE



MODEL: DDC40 R-290

Product features

- Left hinge swing, glass rear door for effortless loading and unloading
- Double pane, curved, front glass which reduces heat transfer and promotes product conservation
- Fully adjustable stainless steel shelves
- Stainless steel floor
- Temperature range 35.6°F to 50°F
- LED lighting for enhanced product display
- Easy-lift front covers for access to condensing unit and easy cleaning
- Electronic temperature controller
- Gravity controlled cooling system
- 1/3 HP compressor
- R-290 ecological refrigerant that reduces and optimizes energy consumption



Product highlights



LED Lighting



Easy access to compressor



Electronic digital controller

Available Color



Accessories

- Castors, lock provided on front set for more security, Castors have a diameter of 4" (102 mm).

Warranty

- 2 year parts and labor
- Additional 3 year compressor coverage

Certifications



Residential: Assumes on liability for parts or labor coverage for component failure, factory defect or any other damages for units installed in non-commercial food service or residential applications.

PRODUCT SPECIFICATIONS

MODEL: DDC40 R-290



Plan view

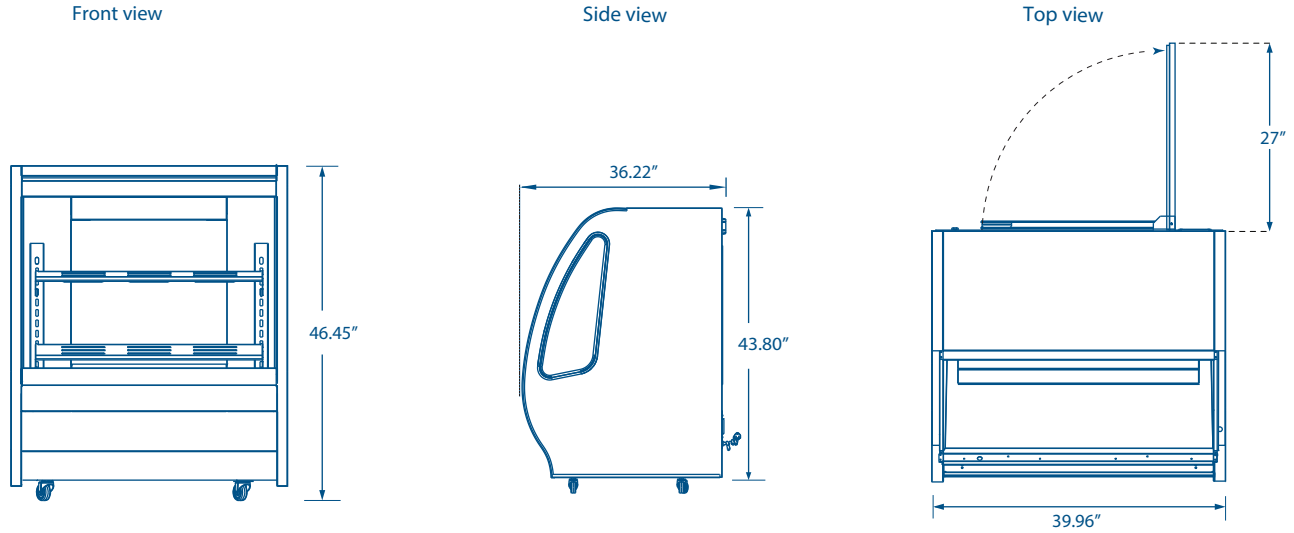

Technical data

Dimensions

External dimensions	W:39.96" D: 36.22" H:46.45"
Internal dimensions	W: 36.77" D: 28.81" H: 32.67"
Net volume	10.34 ft ³ (293 L)
Net weight	273 Lb (124 kg.)
Upper Shelves Dimensions	W: 32.8" D: 18.8"
Lower Shelves Dimensions	W: 32.8" D: 22.8"

Electrical data

Power supply	115 V / 60 Hz
Amps	2.72 A
Length of cord	74.80"
Lighting	LED
Plug type	NEM A 5-15 P
Controller	Electronic

Performance data

Energy consumption	2.8 kW/24 H
Evaporator	Natural convection
Condenser	Air forced

Cooling

Temperature range	35.6°F to 50°F (Exhibition)
Refrigerant	R-290
Refrigerant charge	2.65 oz
Cut In	39.2°F
Cut Out	35.6°F
Compressor power	1/3 HP

Construction

Exterior material	Stainless steel, black and white
Interior material	Stainless Steel and Black/White metal sheet
Number of shelves storage	2
Shelf material	Stainless steel
Door type	Glass Door Swing
Door quantity	1

Logistic data

Trailer Loads	28' fit on a 48' trailer
Trailer Loads	30 fit on a 53' trailer
Unit weight with packaging	344 Lb (156 kg.)
Dimensions with packaging	W: 43.8" D: 41.5" H: 52.1"