



Project _____
 AIA # _____ SIS # _____
 Item # _____ Quantity _____ C.S.I. Section 114000



CL54-BAS ELECTRIC

High Temperature Rack Conveyor Dishwashing Machine



SPECIFIER STATEMENT

Specified dishwasher will be Hobart CL54 Base electric tank heat model. Features include Complete Delime™ with Delime Notification, Auto Dispensing and Booster Guard™, capless anti-clogging wash arms, 245 racks per hour, 114 gallons per hour pumped final rinse, ENERGY STAR®, insulated ergonomic cabinet style doors, touchscreen controls with WiFi connectivity, and NSF approved pot and pan cycle mode. The wash tank utilizes durable precision pressure sensor monitors in lieu of conventional mechanical floats. The 19.5" standard chamber height will accommodate up to (6) standard sheet pans at a time on an open-end sheet pan rack.

STANDARD FEATURES

- + 114 gallons per hour pumped final rinse
- + 245 racks per hour
- + ENERGY STAR® Certified
- + Complete Delime™ with Delime Notification, Auto Dispensing and Booster Guard™
- + Internal stainless steel pressure-less 24 kW booster heater (70°F rise)
 - Single point electrical connection standard
- + Capless, anti-clogging wash arms
- + Large double door opening for ease of cleaning
- + 19.5" chamber height opening (accepts sheet pans)
- + Doors are insulated & hinged with door interlock switches
- + User-friendly smart touchscreen controls with diagnostics & troubleshooting
- + WiFi connectivity
- + SmartConnect app and cloud with machine status, temperature logs, error code reporting, and cost, consumption and usage analysis
- + Energy saver mode (programmable auto-shut down)
- + NSF rated configurable pot and pan cycle
- + Self-aligning wash manifolds
- + Stainless steel self-draining pump and impeller
- + Sloping scrap screens and deep scrap baskets
- + Rapid return conveyor drive mechanism
- + Service diagnostics
- + Door actuated drain closure
- + Vent fan control

OPTIONS & ACCESSORIES (Available at extra cost)

- Standard, short, and extended stainless steel vent hoods
- Direct drive unloader – adds 38" length; Reference spec F48944 for more details
- Side loader – SL23 adds 23" length, SL30 adds 30" length; Reference specs F40926 and F40927 for more details
- Blower-dryer – adds 33¼" to length; Reference spec F48945 (electric blower-dryer) and F48950 (steam blower-dryer) for more details (ships separate from dishmachine, contact Hobart Service for installation)
- Drain water tempering kit
- Flanged feet kit (requires two kits)
- Higher than standard chamber (24" opening)
- Table limit switch with 20' cable
- Correctional package (factory installed, contact Hobart for details)
- Water hammer arrester
- Factory-mounted circuit breakers (contact Hobart for details)

CL SERIES – CL54-BAS ELECTRIC

Approved by _____ Date _____ Approved by _____ Date _____



CL54-BAS ELECTRIC

High Temperature Rack Conveyor Dishwashing Machine

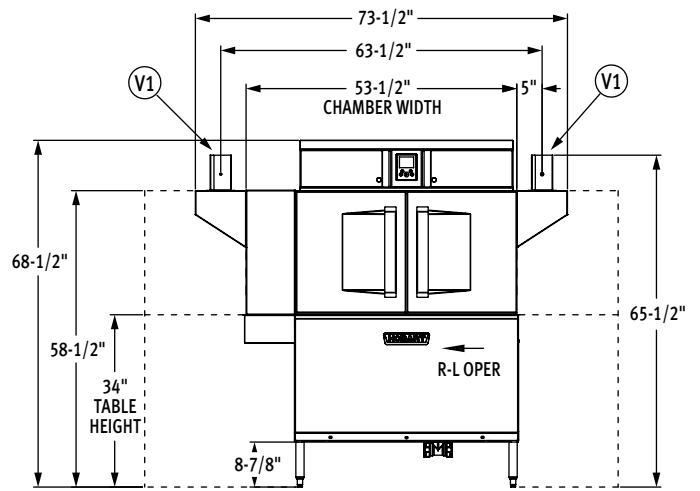
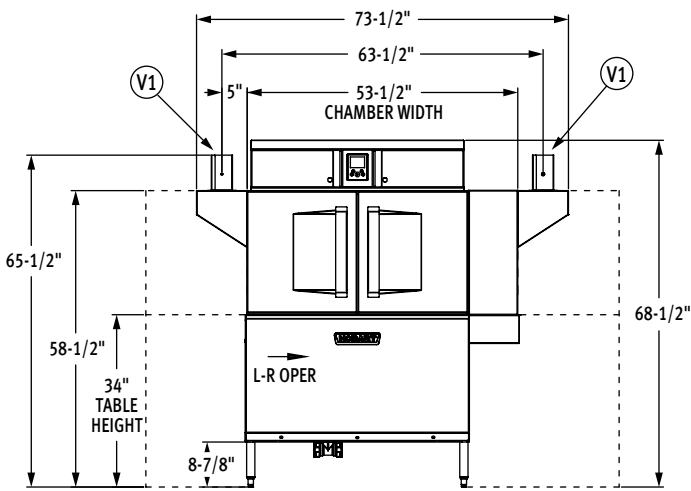
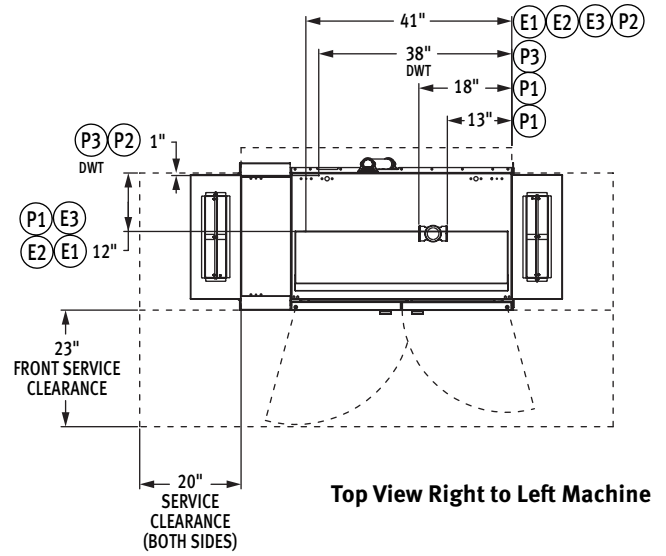
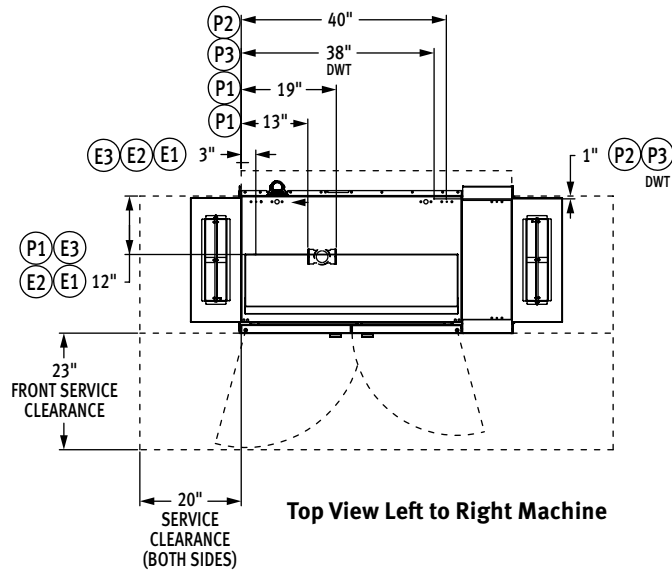

Front View Left to Right Machine

Front View Right to Left Machine

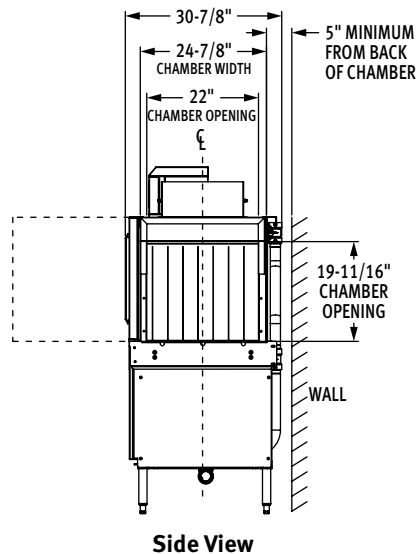

Side View

MODEL: CL54-BAS ELECTRIC
L-R OPERATION
00-563921
REVA

MODEL: CL54-BAS ELECTRIC
R-L OPERATION
00-563931
REVA



CL54-BAS ELECTRIC

High Temperature Rack Conveyor Dishwashing Machine

LEGEND

Electrical Connections	
SINGLE POINT CONNECTION	
E1	Electric connection, single point: motors, controls, tank heat, with 24kW electric booster heater, 65" AFF.
DUAL POINT CONNECTION WITH BOOSTER	
E2	Electric connection: motors, tank heat, 62" AFF.
E3	Electric connection: controls, 24kW booster heater, 65" AFF.
Plumbing Connections	
P1	Drain: 2" FPT, 7-3/8" AFF, two possible connections; may be drained to either side of drain housing, plug opposite side.
P2	Common hot water connection: 1/2" FPT, 12" AFF. See plumbing notes for required temperatures.
P3	Optional drain water tempering. Cold water connection: 1/2" FPT, 12" AFF, cold temperature 80°F maximum.
Vent Connections	
V1	Optional vent hoods: 4" x 16" vent stack with damper. Load end 200 CFM, unload end 400 CFM.

SPECIFICATIONS

Capacities

Racks per Hour (NSF rated)	245
Wash Tank (U.S. gallons)	23
Conveyor Speed (feet per minute)	6.8

Motor Horsepower

Drive	1/6
Wash	2
Final Rinse	2/3

Water Consumption

U.S. Gallons per Hour	114
U.S. Gallons per Rack	0.47
Peak Drain Flow (U.S. gallons per minute)	38

Heating

Tank Heat, Electric (kW)	15
Electric Booster (built-in) (kW for 70°F rise)	24
Electric Booster (field conversion) (kW for 40°F rise)	12

Venting

Load End (minimum CFM)	200
Unload End (minimum CFM)	400

Shipping Weight (approximate)	625 lbs.
Crated Dimensions	63"L x 38"W x 79"H

E1	Single Point Electrical Connection with Internal Booster	
	(E1) Motors, Controls, Tank Heat, 24kW Booster Heater	
Voltage	Rated Amps	Minimum Supply Circuit Ampacity/ Maximum Protective Device
	208/60/3	126.2
240/60/3	114.3	150
480/60/3	59.0	70
600/60/3	44.9	60

E2	Dual Point Electrical Connection with Internal Booster (Field Conversion Only)			
	(E2) Motors, Tank Heat		(E3) Controls, 24kW Booster Heater	
Voltage	Rated Amps	Minimum Supply Circuit Ampacity/ Maximum Protective Device	Rated Amps	Minimum Supply Circuit Ampacity/ Maximum Protective Device
	208/60/3	51.1	70	75.1
240/60/3	48.1	60	66.2	80
480/60/3	24.5	30	34.5	40
600/60/3	16.7	20	28.2	35

WARNING: Electrical and grounding connections must comply with the applicable portions of the National Electrical Code and/or other local electrical codes.

CAUTION: Certain materials including silver, aluminum, and pewter are attacked by sodium hypochlorite (liquid bleach).

ATTN: Plumbing connections must comply with applicable sanitary, safety and plumbing codes.



CL54-BAS ELECTRIC

High Temperature Rack Conveyor Dishwashing Machine

Plumbing Notes: Water hammer arrestor (meeting ASSE-1010 standard or equivalent) to be supplied (by others) in common water supply line at service connection.

Recommended water hardness to be 3 grains or less for best results.

Minimum incoming hot water temperatures:

110°F for 24kW internal booster

140°F for 12kW field converted internal booster

180°F without internal booster for high temperature sanitizing

130°F without internal booster for chemical sanitizing

Building flowing water pressure to dish machine is 20 to 65 PSI at the machine.

For convenience when cleaning, water tap should be installed near machine with heavy duty hose and squeeze valve.

For chemical sanitizing applications, feeder must be certified to NSF Standard 29.

Miscellaneous Notes: All dimensions taken from floor line may be increased approximately 3/4" or decreased 1/2".

For HTS, add 4-5/16" to all dimensions above table line.

For HTS, add 15 lbs. to the domestic shipping weight of each model.

For optimal performance, Hobart recommends maintaining a dishroom temperature of 65°F (18°C) or higher, as lower temperatures may hinder the machine's capacity to operate effectively (with lower performance as ambient temperature decreases).

Electrical Note: Dishmachine not provided with internal GFCI protection.

CL54-BAS Electric Heat Dissipation		
Booster	BTU/HR.	
	Latent	Sensible
Without Booster	18,500	7,900
12kW Booster	26,600	11,400
24kW Booster	37,500	16,100

NOTE: 24kW Booster Heater field convertible to 12kW when 140°F incoming water provided. (Conversion instructions located in machine control box. Contact factory for 12kW booster amperage ratings.)

NOTE: Additional Voltages and Amperages are available, see document F48913.

VENT HOOD OPTIONS (Adjustable, vent stack can be adjusted 1" to either side)

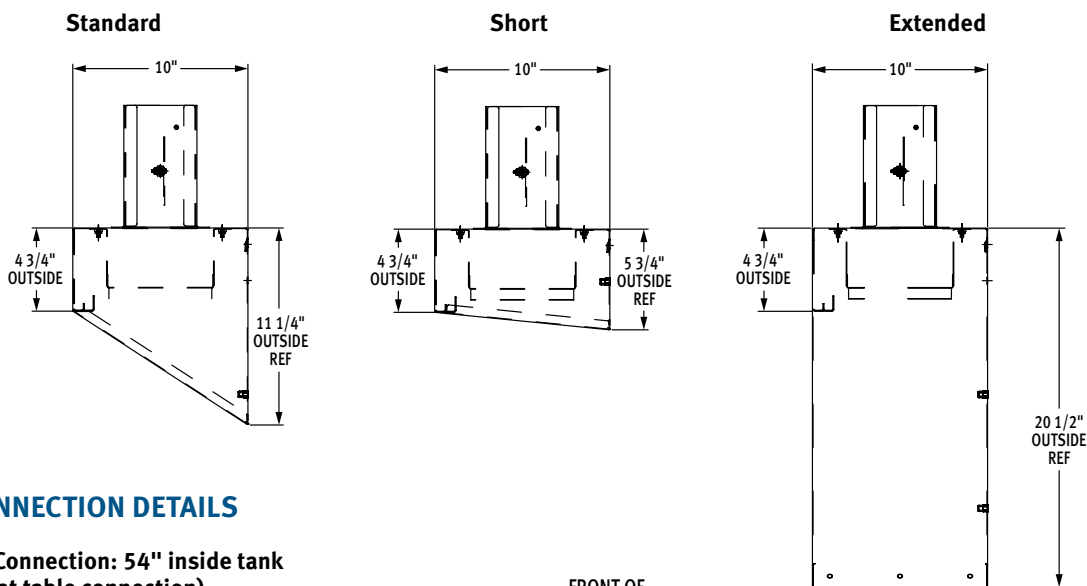
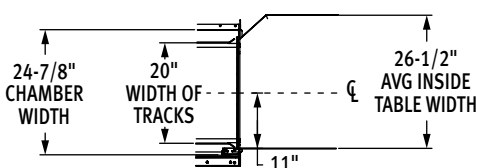
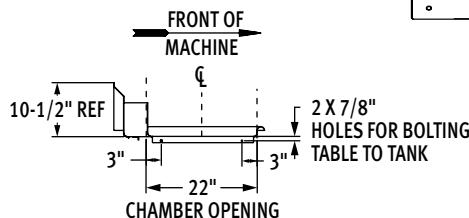

TABLE CONNECTION DETAILS

Tabling Connection: 54" inside tank (at table connection)



Suggested Track and Table Layout



View Showing Hole Locations in Turned Down Portion of Table

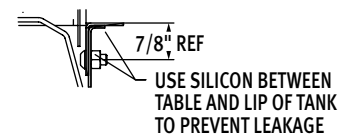

Sectional View Showing Table Connections

As continued product improvement is a policy of Hobart, specifications are subject to change without notice.