



PROJECT NAME: _____

LOCATION: _____

ITEM#: _____ QTY: _____

MODEL: _____

Aluminum Can Racks

Sturdy angled guides make FIFO storage easy!

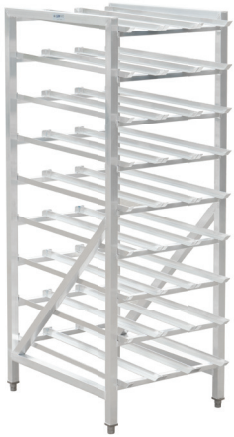

32L-039



32L-042



32L-038

Features:

- Holds #10 and #5 Cans
- Sturdy Aluminum Construction
- 32L-038 includes Aluminum Worktop
- Stationary and Mobile Units Available
- Mobile units include (4) 5" Swivel Casters

Specifications:

Item#	VPN	(L)	(W)	(H)	Capacity (#10 Cans)	Capacity (#5 Cans)	Build	Style	Type
84643	28W-171	24.8"	7.88"	13.25"	10	12	Fully Welded	Countertop / Shelf top	
88812	32L-038	35"	27.5"	40"	72	95	Fully Welded	Mobile	Half Size
89750	32L-039	35"	27.5"	71"	162	216	Fully Welded	Stationary	Full Size
90291	32L-040	35"	27.5"	76"	162	216	Fully Welded	Mobile	Full Size
22801	32L-041	35"	24.75"	71"	162	216	Sides Welded, Knockdown	Stationary	Full Size
42802	32L-042	35"	24.75"	76"	162	216	Sides Welded, Knockdown	Mobile	Full Size

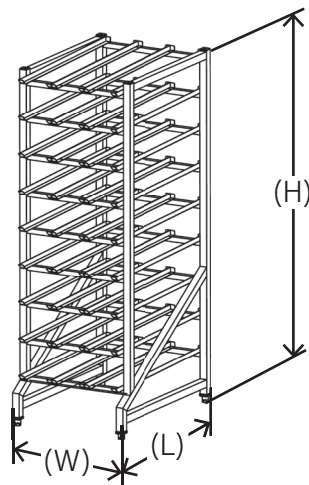
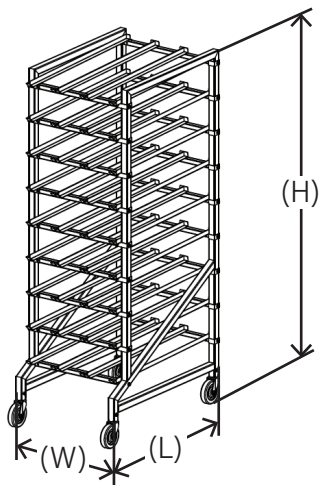

28W-171