



Gas Kebab Machine

Model No.

SWVB-3

SWVB-3

➤ Features:

- Stainless steel structure
- Individually controlled infrared burners
- Power up to 9,500 BTU per burner for natural gas
- Stainless steel heat shield on both sides
- Distance can be adjusted between cooking spit and burners
- Continuous pilot for instant ignition of main burner
- Stainless steel oil collector
- Designed for high performance and consistent results
- Heavy duty motors
- 3/4" NPT rear gas connection

➤ Warranty Info:

One Year

- Parts & Labor on entire unit.
- Valid in United States.
- Valid for commercial use only.



*Conforms to UL Standard 471 and NSF Standard 7
 Certified to CSA Standard C22.2 No. 120*

 Revised **01/01/2026**
SWVB-3

 Phone: (800).768.5953
 Fax: (800).976.1299

 www.servware.com
 Copyright © 2026 Serv-Ware Products LLC.

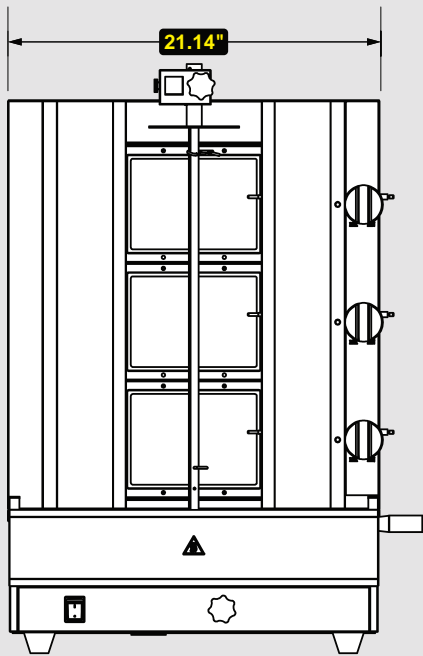

Front View

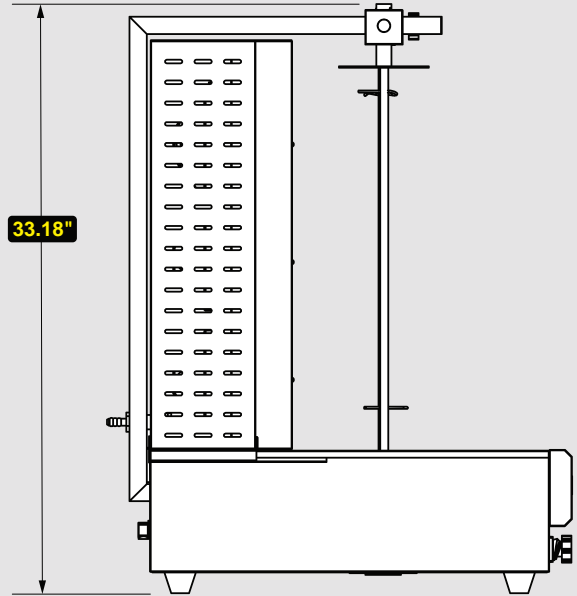

Side View

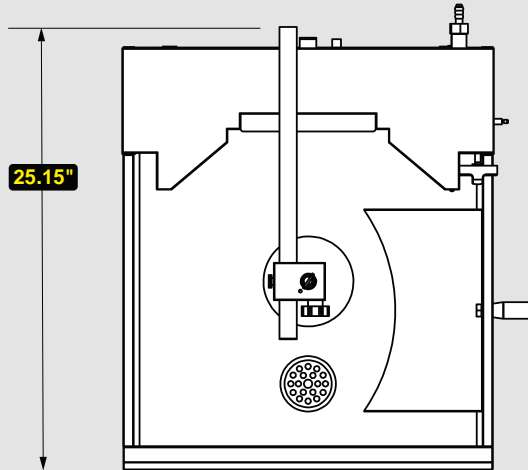

Top View

➔ Technical Information:

MODEL #	DESCRIPTION	DIMENSIONS	WEIGHT/LBS.
		(W x D x H)	(Shipping)
SWVB-3	Gas Kebab Machine-3 Burner	21.14" W x 25.15" D x 33.18" H	65 lbs.

COOKING	
Spit Height	21"
Meat Capacity	65 lbs.
Total BTU/HR	28,500
Gas Line	¾
W.C. for Natural Gas	4 in.

CONSTRUCTION	
Stainless steel	

ELECTRICAL	
Voltage	120
RPM	4



NEMA 5-15P