



GAS STEAM "DO-ALL" COOKER WITH CABINET BASE



- GDA-2S
- GDA-3S

OPERATION SHALL BE BY:

Gas heated steam boiler operating at 9-11 psi (62-76 kPa) rated at 250,000 BTU.

The gas boiler shall be equipped for operation on:

- Natural gas
- Propane gas

The controls shall be equipped for operation on:

- 115 VAC, 1 Phase, 60 Hz

Standard Features

- Water Treatment System
- Universal pan supports for each cooking compartment
- CSD-1 boiler controls
- Split water line
- Electronic ignition

OPTIONS & ACCESSORIES

- | | | |
|--|---|---|
| <input type="checkbox"/> 300,000 BTU boiler | <input type="checkbox"/> Correctional package | <input type="checkbox"/> Wire shelf rack (SSR-PC) |
| <input type="checkbox"/> Stainless steel frame (SSF-) | <input type="checkbox"/> Spray and rinse assembly | <input type="checkbox"/> Sheet pan support (SPS-PC1 or SPS-PC2) |
| <input type="checkbox"/> Stainless steel back on cabinet (SSB-) | <input type="checkbox"/> Water in "Y" strainer (condenser feed) | <input type="checkbox"/> Nickel plated boiler shell (NPBS) |
| <input type="checkbox"/> 220 or 240 VAC, 1 phase, 50 Hz (GBVS-1) | <input type="checkbox"/> Steam take-off kit (STOK) | |

STANDARD CONSTRUCTION SPECIFICATIONS

Shall be a Southbend Steam model **GDA-2S** or **GDA-3S**, pressure and pressureless compartment cooker with gas steam boiler.

The cooker shall be constructed of all-welded satin finish stainless steel, type 304.

The doors shall have a removable inner liner of aluminum plate with full perimeter gasket seal, an outer liner of one-piece all-welded stainless steel, and a wheel-and-screw closing mechanism.

The doors, with a clear opening of 10-1/4" x 26-3/8", shall latch upon closing and shall open 15° upon latch release.

The lower compartment shall be a pressure cooker only and shall operate at a maximum pressure of 6 psi (41 kPa).

The upper compartment shall be either a pressureless free venting cooker or a pressure cooker operating at a maximum of 6 psi (41 kPa), as selected by the operator.

The control housing shall be constructed of stainless steel with a full access removable panel.

Each compartment shall have independent automatic timer controls with visual and audible signals.

In the lower compartment and the pressure mode of the upper compartment, the controls automatically shut off and exhaust the incoming steam, drain the condensate from the compartment and sound a continuous signal until turned off manually.

In the pressureless mode of the upper compartment, the controls shall also include a mode selector switch and a steam flow cut-off when the door is opened.

The compartment cooker shall be mounted on a cabinet base with full perimeter angle frame, reinforced counter and boiler mountings, gas boiler with controls, all stainless steel exterior, hinged doors and 6" (152 mm) stainless steel legs with 4 adjustable flanged feet for mounting to the floor.

Water treatment system, automatic blow down, CSD-1 boiler controls, split water line, and electronic ignition come standard.

SEE REVERSE SIDE OF SPEC SHEET FOR WATER TREATMENT SYSTEM STATEMENTS



Approval Notes: _____

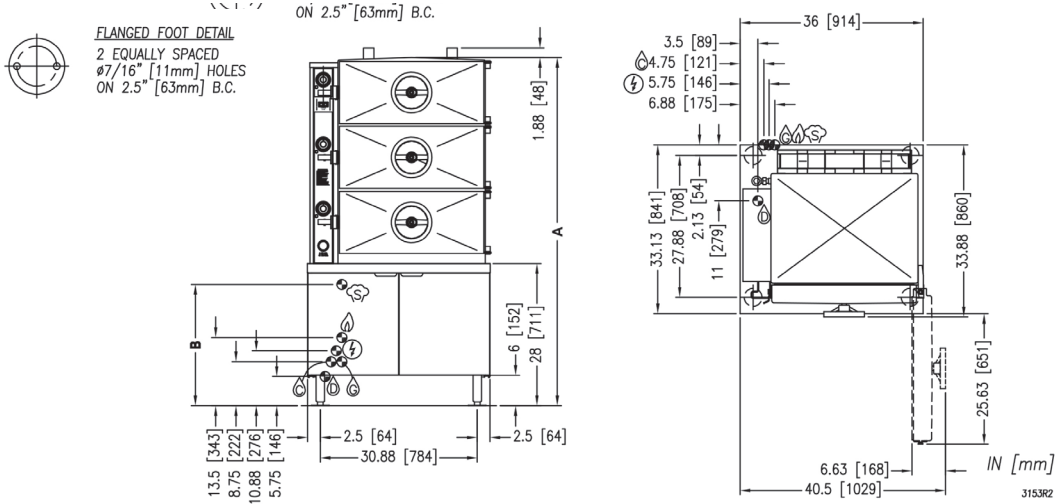

SERVICE CONNECTIONS

- ELECTRICAL CONNECTIONS: 1/2" (13 mm) conduit connection to controls. 2 Amps per compartment, 120-60-1, 220-50-1.
- GENERATOR WATER: 1/2" (13 mm) NPT at 25-50 PSI (170-345 kPa).
- DRAIN: 2" (51 mm) IPS piped to open floor drain. No solid connection.
- GAS CONNECTION: 3/4" (19 mm) IPS supply line required.
- COLD WATER: 1/2" (13 mm) NPT at 25-50 PSI (170-345 kPa).
- STEAM TAKE-OFF CONNECTION: 3/4" IPS optional to operate adjacent equipment.

DIMENSIONS

Model	Units	A	B (250k BTU)	B (300k BTU)
GDA-2S	in (mm)	55.75" (1416)	23.88" (606)	20.88" (530)
GDA-3S	in (mm)	68.5" (1740)		

UTILITIES AND COMPARTMENT PAN CAPACITY

MODEL	BTU/HOUR	KW/HOUR	WATER COLUMN PRESSURE		MODEL	COMPARTMENTS	CAPACITY
GDA-2S or GDA-3S	250,000	73.33	Propane min. 11" (279 mm)	Natural min. 7" (178 mm)	GDA-2S	2	8-16 Pans
	300,000	87.9			GDA-3S	3	12-24 Pans

WATER QUALITY STATEMENT

Water is the essential ingredient in steam equipment, water quality is the major factor affecting the performance of your appliance. Crown Steam Group offers a Comprehensive Water Treatment System which exceeds our minimum water requirements. Proof of installation and proper cartridges replacement is required for warranty coverage. Water supply to Crown Steam Group steamers must be within these guidelines.

Total dissolved solids.....	Less than 60 PPM	Chlorine	Less than 1.5 PPM
Total alkalinity	Less than 20 PPM	pH Factor	6.8 - 7.3
Silica.....	Less than 13 PPM		

Water which does not meet these standards should be treated with the installation of Middleby's Water Treatment System. Call 919-762-1000 if you have questions concerning your water meeting these parameters.

*Failure or malfunction of this appliance due to poor water quality is not covered under warranty.
Reference www.crownsteamgroup.com for complete warranty details and instructions.

DISCLAIMER

Terry System Cartridge Changes / Installation – "2-3 gallons of water MUST be purged at each cartridge change or new installation prior to water supply being fed to the steamer. Failure to do so can result in component damage within the steamer which is not covered under warranty. For additional guidance on proper installation, refer to install documentation provided with each Terry System and Replacement Cartridge Set."

**INTENDED FOR COMMERCIAL USE ONLY.
 NOT FOR HOUSEHOLD USE.**

