



Item #

Project :

Qty :

Electric Range with Oven

Model No.

SWER-24



SWER-24

Features:

- Stainless steel front, galvanized sides
- Electric hotplate, 2.6kw and 2kw combination
- Thermostat (112°- 500°) controlled oven
- Spacious static oven cavity
- Top and bottom heating elements
- Welded frame structure for best stability
- Separate controls on the oven
- Adjustable heavy duty legs
- A pull-out crumb tray with angled handle in the front
- Stainless steel oven door with insulation
- Stainless steel handle for bottom oven
- Kick plate at the bottom for easy access for servicing

Warranty Info:

Three Year

- Parts & Labor on entire unit.
- Valid in United States.
- Valid for commercial use only.



Conforms to UL Standard 471 and NSF Standard 7
 Certified to CSA Standard C22.2 No. 120

Revised 01/01/2026

SWER-24

Phone:(800).768.5953
 Fax:(800).976.1299

www.servware.com
 Copyright © 2026 Serv-Ware Products LLC.

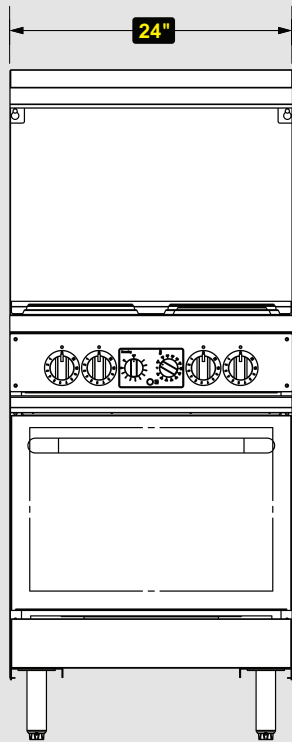

Front View

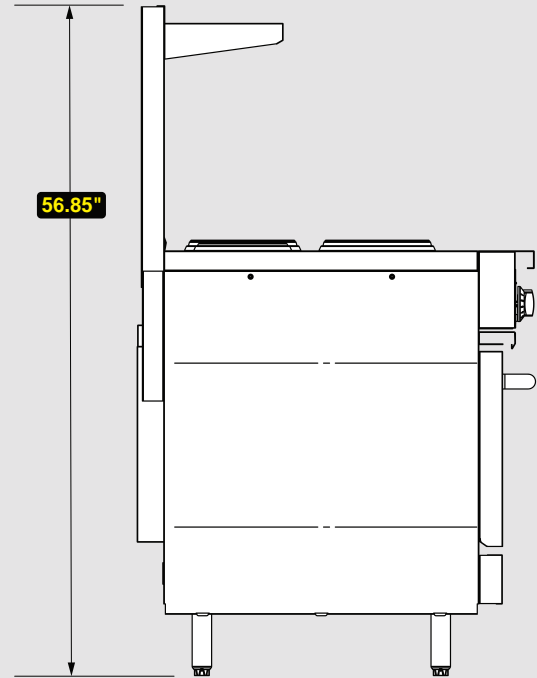

Side View

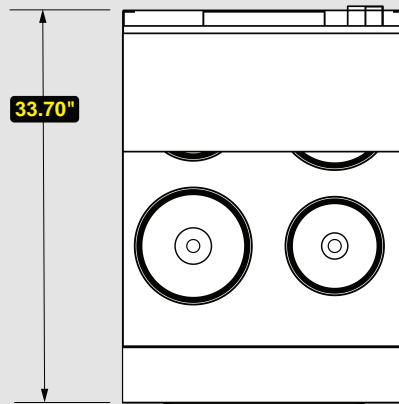

Top View



NEMA 5-15P

➔ Technical Information:

MODEL #	DESCRIPTION	DIMENSIONS	WEIGHT/LBS.
		(W x D x H)	(Shipping)
SWER-24	4 Burner Electric Range With Oven	24" W x 33.70" D x 56.85" H	330 lbs.

COOKING	
Oven Size	20.5" W x 24" D x 13.9" H
Oven Thermostatic	112° - 500°
Electric Hot Plates	4 separate
Electric Hot Plates kw	2.6 & 2 combo

ELECTRICAL	
Voltage	208
Kw	13.6
Amps	65
Hz	60
Phase	1

CONSTRUCTION
Welded frame, stainless steel construction with high density insulation